



**SURLY**

**2011 BIKE STUFF**

# Surly Trailers

There are quite a few options these days for trailers that carry kids or dogs, luggage, groceries, and other relatively small loads. Trailers are nice because they can be detached when not in use, but most trailers can't haul much weight and the ones that do suffer some design drawbacks such as incompatibility with many kinds of bikes. Conversely, there are quite a few cargo bikes that can haul bigger loads, but cargo bikes meant for a lot of weight can be difficult to load, are sometimes difficult to ride (sometimes due to the bike's design, and sometimes due to the sheer weight of the bike itself), and require a lot of space to store. We felt we could help bridge the gap, so we designed two trailers meant to haul a lot, to be easy to use, and which would work with a bike you have already.

We make two bed lengths so you can find one that suits your needs. The beds and hitch are constructed mainly of TIG-welded 4130 CroMoly steel. CroMoly steel is tough and durable and well-suited to this task. We used 304 stainless steel hardware where appropriate to ensure corrosion resistance and a long life. The beds have threaded eyelets for bolting down decking, corner posts, or creating other custom accessories using readily-accessible materials from your local hardware store, lumberyard or home improvement store.

The wheels are 16", keeping cargo low to the ground. 16" wheels are also stronger than larger diameter wheels favored by many trailers. We designed our own hubs to meet the requirements of this frame. The rims are double-wall with stainless eyelets. The spokes are stainless steel, radially laced. Combined with smooth, easy rolling 1.95" tires, these are stout wheels designed specific to their purpose.

Our hitch system is designed to be as universal as possible. Regardless of the configuration of your bike frame, our hitch will likely fit your bike. It doesn't clamp to the bike's frame tubes. Instead, it attaches using a proprietary axle skewer or thread-on axle nuts. The Surly trailer hitch works with full-suspension frames, disc brakes, rear racks and fenders. It adjusts to accommodate hub widths from 120-145mm and allows you to align the centerline of the trailer on the centerline of the bike. It will work with bikes that have wheels as small as 20" and as large as 29" while keeping the bed level with the ground. This is especially important when you are hauling long items that hang off the back of the trailer (lumber, tubing, ladders, etc.).

There are some things to learn about using a trailer like this to haul stuff. You'll probably want to use a bike with gears, for example. As well, learning to load it right becomes more important as cargo weight increases. Load it over the axles, balancing the load. Too much weight on the hitch (tongue weight), or too much weight hanging off the back, and the bike's handling will be compromised, making it harder to control and potentially damaging your bike, the trailer, or you. Finally, we do not recommend ever carrying people or furry friends on Surly trailers. Sure it might be fun, but someone could get seriously hurt and that's not fun at all.

**Tubing:** 4130 CroMoly steel. TIG-welded.

**Hitch-to-frame compatibility:** Surly trailers connect to your frame via B.O.B. Nuts. The hitch is width adjustable to fit most frames from 120-145mm O.L.D. (rear hub) spacing.

**Bicycle wheel compatibility:** The hitch will fit a wide variety of wheel diameters, from 20" up to 29", accommodating up to a 29x2.6" tire. Sorry, it won't work with snowbike rims and tires, such as our Large Marge or Larrys.

**Platform dimensions, shortbed:** 32 x 24" (813 x 610mm)

**Platform dimensions, longbed:** 63 x 24" (1608 x 610mm)

**Maximum tongue load:** 50 lb (22.7kg)

**Maximum total load:** 300 lb (136kg)

**Braze-ons:** 5x1mm threaded barrels for securing a platform; corner stake eyelets

**Trailer tire clearance:** Our trailers come with 16 x 1.95" tires. There is clearance for 16 x 2.5" tires.

**Color:** Silver with black hitch

**Weight of long bed frame:** N/A **Weight of short bed frame:** N/A **Weight of hitch assembly:** N/A



The frame is a solid unit constructed of welded CroMoly steel square tubes. The hitch can be adjusted to level the bed, making it easier to carry long items.

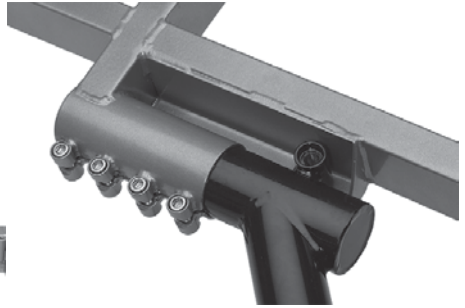

The wheel covers keep cargo from shifting into spokes and provide load-bearing support for items that don't fit between them. Threaded bosses, in the wheel covers, provide mounting points for fenders and spoke guards (not included).



The hitch is highly adjustable to fit most types of bikes and a wide variety of wheel diameters and hub widths.

# Big Dummy™ Frameset

The Big Dummy is designed for carrying cargo. Like all our frames, it's made of steel and it's got lots of little touches that you've come to love in a Surly, like clearance for bigger tires and common component sizing.

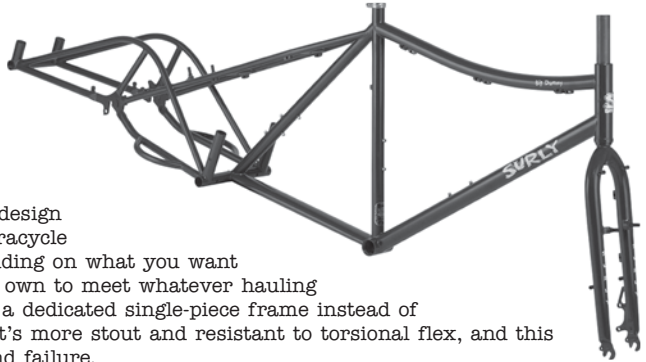

It's built around the Xtracycle design platform, which means that Xtracycle accessories can be added depending on what you want to carry, or you can build your own to meet whatever hauling need you have. However, being a dedicated single-piece frame instead of an add-on to an existing bike, it's more stout and resistant to torsional flex, and this makes it resistant to fatigue and failure.

Figure on being able to carry about 200 pounds (90kg) of cargo. The load weight, and how it's loaded, will affect the handling somewhat. Also plan on using gears, especially as cargo weight increases. This may seem obvious, but as you get comfy with it you'll use your full range of gears as never before.

One of the funny things about the Big Dummy is that it doesn't ride quite like you might think. Sure, it's a little longer, but mainly it rides like a bike. It's smooth, maneuverable, even nimble. Are you riding light and want to hit some singletrack on the way home? Do it. And if you get a call from your better half asking you to pick up some groceries, or you see a nice lamp at a garage sale, you're all ready. Lots of people bought one to use once in a while and began using it as their everyday ride.

The frame can be built up lots of different ways to suit your needs and budget. The complete bike option has been reconfigured this year to help keep the price down while still retaining durable, quality components Surly is known for.

## Big Dummy Specifications:

**Tubing:** Surly 4130 CroMoly steel. Main triangle double-butt. TIG-welded

**Rear dropouts:** Vertical, 135mm spaced with fender eyelets

**Brake compatibility:** 51mm disc mounts and removable cantilever pivots

**Braze-ons:** Triple water bottle mounts, guides for continuous brake/shift housing or brake hydraulic line (toptube and seatstay routing), fender eyelets

**Seatpost diameter:** 27.2mm

**Seatpost clamp:** 30mm Surly stainless, included

**Headset:** 1-1/8" threadless

**Front Derailleur:** 28.6mm (1-1/8") clamp diameter, top-pull style

**Bottom bracket shell:** 68mm wide, threaded English 1.37" x 24t

**Tire clearance:** 26 x 2.5" with fenders

**Chainring clearance:** No frame limitations. Use whatever you want

**Fork:** TIG-welded 4130 CroMoly, suspension-corrected (80mm travel), tapered straight blade with single fender eyelet on the dropout, 1-1/8" x 260mm threadless steerer, 51mm IS disc mount, removable cantilever pivots, line/housing guides

**Cargo Weight Limit** 400 lb combined rider and cargo

**Color:** Tar Pit Black

**Weight:** 5727g (12.6 lb)    **Fork:** uncut = 1304g (2.9 lb)

# Big Dummy™ Complete



## Component Sizing

size	Stem length		stem angle degrees	Hbar width		Crank length mm
	inch	mm		inch	mm	
<b>16"</b>	3.5	90.0	7	26.0	660	170
<b>18"</b>	3.9	100.0	7	26.0	660	175
<b>20"</b>	4.3	110.0	7	26.0	660	175
<b>22"</b>	4.7	120.0	7	26.0	660	175

See page 39 for a complete BD frame geometry grid.

**Color:** Black

**Component sizing and spec may vary.**

## Bike Specifications:

Component	Type	Description
Frame	Surly Big Dummy	Surly 4130 CroMoly steel. TIG-welded. Main triangle double-butted
Fork	Surly Big Dummy	Surly 4130 CroMoly steel. TIG-welded. 1-1/8" threadless steer tube, uncut
Headset	Ritchey Logic Comp	1-1/8" threadless, w/40mm spacers. Black
Stem	Kalloy, AS-008	1-1/8" threadless. Forged. 25.4mm clamp diameter. Black
Handlebar	Salsa Moto Ace	660mm wide. 17". Black
Grips	Velo Kraton	Rubbery. Black
Brake Levers	Avid FR-5	Destroy all monsters
Brakes	Avid BB7	Cable-actuated disc. 185mm rotors front & rear
Crankset/BB	TruVativ FireX C3.1	Forged aluminum. 48-36-26t. Black
Seatpost	Kalloy SP-342	27.2 x 350mm. Single-bolt cradle clamp. Black
Seatpost Clamp	Surly stainless	30.0mm. Stainless steel. Black
Saddle	WTB SST	Vinyl cover. CroMoly rails. Black
Cassette	Shimano HG-61	9-speed, 11-34t
Chain	SRAM PC-971	9-speed
Hubs	Shimano Deore	M525 Disc. 36h. Black
Front Derailleur	Shimano Deore	FD-M591 Traditional style dual pull. 28.6mm clamp
Rear Derailleur	Shimano Deore Long Cage	RD-M591 SGS. Top-normal traditional
Shifters	Shimano Deore	SL-M590. 9-speed shifter pair
Rims	Salsa Gordo	26". 36h. Black w/machined sidewalls
Spokes	DT Champion	14g/2.0mm straight gauge stainless. 12mm silver brass nipples
Tires	Continental Town & Country	26 x 2.1". Steel bead.
Cargo System	Xtracycle Kit	Snapdeck, left & right V-racks, left & right Freeloader bags

Standard one-leg kickstand included. Pedals not included

More cargo accessories are available from Xtracycle. Visit them at [Xtracycle.com](http://Xtracycle.com)

# Long Haul Trucker™ Frameset

A touring bike's job is to go the distance (and then some), in relative comfort, while carrying you and your gear. The Long Haul Trucker was designed in all aspects to get you and your stuff to...

wherever. Its low bottom bracket and long chainstays provide comfort and stability, and those long stays increase heel clearance when carrying packed panniers. We

gave it ample tire clearance for larger tires (larger tires soak up a lot of road static) with room for fenders too. The frame's tubing is thicker-walled and

larger-diameter than standard road and sport-touring frames, and this pre-tunes it for the weight of cargo. And it's got braze-ons for everything you're likely to need, from

racks to water bottle cages to spare spokes.



Like all our frames, it's made of CroMoly steel. We like steel for a lot of reasons. Foremost among them is the ride quality a well designed steel frame delivers. It doesn't hurt that steel is relatively inexpensive, or that it is more easily repaired than aluminum, carbon fiber or titanium. You'll probably never need to have the frame repaired, but if you do you're more likely to find someone who can weld steel than someone who can weld TI or aluminum. Repair carbon fiber? Good luck with that.

We offer the LHT as a frameset or as a complete bike. The "Trucker is available in a 26" wheel size across the size run, with an option for 700c in 56, 58, 60 and 62cm sizes. Some people prefer the larger diameter 700c, and that's cool. 26" is a more popular size around the world, however, so you'll more easily be able to find replacement tubes, tires, and rims should the need arise. Smaller wheels are also stronger than their 700c counterparts, so they'll stand up better to rough roads and heavy loads.

The LHT complete is set up with quality parts meant for the purpose of this bike. Add racks, fenders, pedals, and bags and then, well...go someplace.

## Long Haul Trucker Specifications:

**Tubing:** Surly 4130 CroMoly steel. Main triangle double-buttet. TIG-welded

**Rear dropouts:** Vertical, 135mm spaced

**Brake compatibility:** Linear-pull or traditional cantilever

**Braze-ons:** Upper bosses and dropout eyelets for racks front and rear, fender eyelets, chainstay spare spoke holder, pump peg, downtube lever bosses, 3 sets of H<sub>2</sub>O cage bosses, rear housing stop for canti brakes, housing stops for brakes and derailleurs

**Seatpost diameter:** 27.2mm

**Seatpost clamp:** 30mm Surly stainless, included

**Headset:** 1-1/8" threadless

**Front Derailleur Clamp Diameter:** 28.6mm

**Bottom bracket shell:** 68mm wide, 1.37" x 24t

**Chainring clearance:** 42/53t double, 38/52/56t triple (max. tooth size)

**Tire Clearance:** Fits tires up to 26 x 2.1"/700c x 42mm with room for fenders

**Fork:** 4130 CroMoly, lugged and brazed, tapered curved blades with lowrider rack eyelets

**Color:** Black or Hill Street Blue.

**Weight:** 58cm frame = 2,340g (5.15 lb)

**Fork:** uncut = 1,020g (2.25 lb)

# Long Haul Trucker™ Complete



## Component Sizing

Size	Stem Length		Stem Angle** degrees	Hbar Width		Crank Length mm
	inch	mm		inch	mm	
<b>42cm</b>	3.0	75.0	35.0	15.7	400.0	165.0
<b>46cm</b>	3.0	75.0	35.0	15.7	400.0	165.0
<b>50cm</b>	3.0	75.0	35.0	16.5	420.0	170.0
<b>52cm</b>	3.5	90.0	17.0	16.5	420.0	170.0
<b>54cm</b>	3.9	100.0	17.0	16.5	420.0	170.0
<b>56cm</b>	3.9	100.0	17.0	16.5	420.0	175.0
<b>58cm</b>	4.3	110.0	17.0	17.3	440.0	175.0
<b>60cm</b>	4.7	120.0	17.0	18.1	460.0	175.0
<b>62cm</b>	4.7	120.0	17.0	18.1	460.0	175.0

See page 40 for a complete LHT frame geometry grid.

**Color:** Black

**Component sizing and spec may vary.**

\*\*Stems can be flip-flopped to customize angle

## Bike Specifications:

Component	Type	Description
Frame	Surly Long Haul Trucker	Surly 4130 CroMoly steel. Main triangle double butted. TIG-welded
Fork	Surly Long Haul Trucker	CroMoly, lugged and brazed. 1-1/8" threadless steer tube, uncut
Headset	Ritchey Logic Comp	1-1/8" threadless, w/40mm spacers. Black
Stem	Kalloy AS-009	1-1/8" threadless. Forged. 26.0mm clamp. Silver
Handlebar	PMT	Aluminum. Silver
Handlebar Wrap	Co-Union Cork Mix	Black
Brake Levers	Tektro	RL340 standard levers on 52-62cm sizes, RL341 small hand levers on 42-50cm
Brakes	Tektro Oryx cantilever	#992. Silver
Cable Hanger, front	Tektro	#1271A w/noodle. Silver
Shifting Shifters	Shimano Bar End	SL-BS77 9-speed
Front Derailleur	Shimano Tiagra	FD-4603BS triple
Rear Derailleur	Shimano XT	RD-M771SGS top-normal long cage
Crankset	Andel	Forged arms. Silver. Aluminum rings, 110mm BCD, 48-36-26t
Bottom Bracket	Shimano	UN54 square taper. 68 x 118mm
Seatpost	Kalloy SP-248D	27.2 x 300mm. Silver
Seatpost Clamp	Surly Stainless	Natural Silver
Saddle	WTB SST	Vinyl top. CroMoly rails. Black
Cassette	Shimano	CS-HG50. 9-speed. 11-13-15-17-20-23-26-30-34t
Chain	SRAM	PC971 9-speed
Hubs	Shimano XT	M770. 36h. Silver
Spokes	DT Swiss	14g stainless. Silver
Rims	Alex Adventurer	36h. Black w/eyelets
Tires	Continental Contact City	26 x 1.5", Black wall
	Continental Contact	700c x 37mm, Black wall
Tubes	Cheng Shin	700c x 35mm or 26 x 1.5"

Extras: Clear chainstay protector. Die-extruded cables with anti-rattle donuts. Full CPSC reflector kit. Generic owner's manual

# Karate Monkey™ 29" Frameset

Although even now in many places 29ers are still considered oddball, suspect, or downright alien, many people believe 29ers to be the best tool in the kit for riding singletrack, gravel, and a lot of other offroad conditions. Big wheels deliver greater traction than their 26" counterparts, they offer a better ground approach angle, which helps make uneven terrain more easily rideable, they hold inertia well, and they generally fit taller riders better than 26" bikes. The Karate Monkey's been around for a while. It didn't create the 29er category, but it helped bring it to the masses and set the standard for what a 29er could be.



Surly custom 4130 CroMoly tubing throughout sets the stage for a lively and fast, yet forgiving, ride. We curved the seat tube forward to allow the wheel to tuck under, meaning the thing rips in twisty stuff. The frame and fork has lots of clearance for big fat tires, and the frame is suspension corrected for an 85mm suspension fork. In true Surly fashion, it's got a lot of built-in versatility. The rear dropouts are horizontal with a derailleur hanger, so you can run as a singlespeed, a fixed-gear, or with full gears and derailleurs. It's got removeable rim brake pivots as well as disc caliper mounting plates. This year we've redesigned the rear-disc caliper mount to make removing and installing the rear wheel easier than before. Also new, we replaced housing stops with line guides for running full housing for brakes and derailleurs. Like many of our models, we offer it as a frameset and also as a complete bike. The complete bike option, like all our bikes, is composed of durable stuff that's right for the task at hand and not too spendy.

We're not here to tell you that you need this bike. That's not really our style. And anyway, you probably don't need it. You probably have several bikes already. And yet, we hear from people all the time who tell us their other bikes sit gathering dust ever since they started riding a Karate Monkey. You'd be hard pressed to find a better riding, more durable, and more versatile 29er. The Karate Monkey walks tall, speaks softly and kicks ass.

## Karate Monkey Specifications:

**Tubeing:** Surly 4130 CroMoly steel. Main triangle double-butted. TIG-welded

**Rear dropouts:** Surly horizontal dropouts with derailleur hanger, 135mm spaced

**Brake compatibility:** 51mm disc mounts or cantilever rim-type

**Braze-ons:** Cantilever bosses with removable pivots, dual water bottle mounts, downtube shift cable routing, guides for hydraulic hose or solid housing on the seatstay, Surly Trip Guides for running full length housing for brakes and derailleurs.

**Seatpost diameter:** 27.2mm

**Seatpost clamp:** 30mm Surly stainless, included

**Headset:** 1-1/8" threadless

**Front Derailleur Clamp Diameter:** 28.6mm

**Bottom bracket shell:** 73mm wide, 1.37" x 24t

**Chainring clearance:** 48t max

**Tire Clearance:** Fits up to 29 x 2.55" knobbies

**Fork:** Suspension-corrected (85mm), tapered straight blade, 4130 CroMoly. 51mm IS disc mount and removable canti pivots

**Color:** Battleship Gray and Stretchpants Black

**Weight:** 20" frame = 2,500g (5.5 lb)    **Fork:** uncut = 1,180g (2.6 lb)



# Karate Monkey™ Complete



## Component Sizing

size	stem length		stem angle degrees	Hbar width		Crank length mm
	inch	mm		inch	mm	
16"	3.5	90	7	26.0	660	175
18"	3.9	100	7	26.0	660	175
20"	4.3	110	7	26.0	660	180
22"	4.7	120	7	26.0	660	180

See page 41 for a complete KM frame geometry grid.

**Color:** Battleship Gray or Stretchpants Black  
**Component sizing and spec may vary.**

## Bike Specifications

Component	Type	Description
Frame	Surly Karate Monkey	Surly 4130 CroMoly steel. TIG-welded. Main triangle double-butted
Fork	Surly Karate Monkey	Surly 4130 CroMoly steel. TIG-welded. 1-1/8" threadless steer tube, uncut
Headset	Ritchey Logic Comp	1-1/8" threadless, w/30mm spacers. Black
Stem	Kalloy AS-008	1-1/8" threadless. Forged. 25.4mm clamp diameter. Black
Handlebar	Salsa Moto Ace	25.4mm clamp diameter. 660mm wide. Black
Grips	Velo Kraton	Rubbery. Black
Brake Levers	Avid FR-5	Destroy all monsters
Brakes	Avid BB7	Cable-actuated disc. 160mm rotors front & rear
Crankset/BB	TruVativ FireX 1.1	Forged aluminum. 33t. Black.
Seatpost	Kalloy SP-342	27.2 x 350mm. Single-bolt cradle clamp. Black
Seatpost Clamp	Surly stainless	30.0mm. Stainless steel. Black
Saddle	WTB SST	Vinyl. CroMoly rails. Black
Freewheel	Shimano singlespeed	3/32". 17t
Chain	SRAM	PC-830. 3/32"
Hubs	Surly New Model Hubs	32h. Nutted rear axle, QR front axle. Black
Rims	Salsa Delgado	700c, 32h. Black w/machined sidewalls
Spokes	DT Champion	14g/2.0mm straight gauge stainless. 12mm silver brass nipples
Tires	WTB Exiwolf DNA	29 x 2.3". Steel bead. Black

Pedals not included

# Pacer™ Frameset

Behold the Pacer. For years we sold it only as a frameset. It was understated, didn't draw a lot of attention to itself, but it rode great and people who rode one loved it.

The Pacer is not what most race-inspired roadies seem to drool over. It isn't on the cutting edge of design, it isn't made of the ultra-light, super-expensive materials, and it isn't festooned with lots of bright colors and graphics. Rather, it is a road bike made of our favorite material, CroMoly steel, using frame geometry that makes it fast and efficient like a road bike should be. But this is not a racing frame. This is a frame meant for all-day rides. There are a lot of other road frames out there that are flashier, more exotic, and full of promises most riders only dream of fulfilling. The Pacer doesn't make promises. It's simply a great riding steel frame.



We decided to offer it as a complete bike to make it easier for folks to try one. It's comfy but responds when you push hard on the pedals. It's got plenty of tire clearance for larger tires. Since tire casings flex before the frame, higher volume tires to take the edge off the bumps and jangles which otherwise can harsh your ride. We gave the complete 28mm tires, a good all-around size that will still allow you to add fenders if you like. As you might expect, we built it up with a parts kit that is more than capable, but not snobbish or unnecessarily expensive. The Pacer reminds us, quietly, that there is a road bike out there for the rest of us.

## Pacer Specifications:

**Tubing:** Surly 4130 CroMoly steel. Main triangle double-butted. TIG-welded

**Rear dropouts:** Vertical Breeze-In dropouts, 130mm spaced

**Brake compatibility:** Standard reach post-mount road calipers

**Braze-ons:** Single fender eyelets front and rear, dual water bottle mounts, and pump peg (54cm and larger)

**Seatpost diameter:** 27.2mm

**Seatpost clamp:** 30.0mm Surly stainless, included

**Headset:** 1-1/8" threadless

**Front Derailleur Clamp Diameter:** 28.6mm

**Bottom bracket shell:** 68mm wide, threaded English 1.37" x 24t

**Tire clearance:** Room for 700c x 32mm or 700c x 28mm with fenders

**Color:** British Racing Green

**Weight:** 56cm = 4.45 lb (2.02kg)     **Fork:** uncut = 2.09 lb (0.95kg)

# Pacer™ Complete



## Component Sizing:

Size	Stem Length		Stem Angle	Hbar Width c-t-c		Crank Length
	inches	mm	degrees	inches	mm	mm
<b>42cm</b>	3.1	80	7	15.7	400	170
<b>46cm</b>	3.1	80	7	15.7	400	170
<b>50cm</b>	3.5	90	7	16.5	420	170
<b>52cm</b>	3.5	90	7	16.5	420	170
<b>54cm</b>	3.9	100	7	16.5	420	172.5
<b>56cm</b>	3.9	100	7	17.3	440	172.5
<b>58cm</b>	4.3	110	7	17.3	440	175
<b>60cm</b>	4.7	120	7	18.1	460	175
<b>62cm</b>	4.7	120	7	18.1	460	175

See page 42 for a complete Pacer frame geometry grid.

**Color:** British Racing Green

**Component sizing and spec may vary.**

## Bike Specifications

Component	Type	Description
Frame	Surly Pacer	Surly 4130 CroMoly steel. Main triangle double butted. TIG welded
Fork	Surly Pacer	Surly 4130 CroMoly steel. Lugged and brazed. 1-1/8" threadless steer tube, uncut
Headset	Ritchey Logic Comp	1-1/8" threadless, w/30mm spacers. Hset black, spacers silver
Stem	Kalloy AS-008	1-1/8" threadless, 26.0mm bar clamp. Silver
Handlebar	Salsa Short & Shallow	Ergonomic. Silver
Handlebar wrap	Co-Union Cork	Black. Grippy
Brake/shift levers	Shimano Tiagra STI	ST4500. Short reach inserts installed for 42-54cm frame sizes.
Brakes	Tektro R358	Silver
Front derailleur	Shimano Tiagra	FD4500. Bottom pull
Rear derailleur	Shimano Tiagra	RD4500SS. Short cage
Crankset	FSA Vero	50/34t. Silver. 110mm BCD
Bottom bracket	Shimano	UN54 square taper. 68 x 107mm
Seatpost	Kalloy SP-248	27.2 x 350mm. Silver
Seatpost clamp	Surly stainless	Black. 30.0mm
Saddle	WTB SST	Vinyl, Lionel. Cro, Molly. Black, Jack
Cassette	Shimano Tiagra	HG50 9-speed. 12-13-14-15-17-19-21-23-25t
Chain	SRAM PC971	9-speed 3/32"
Hubs	Shimano Tiagra	FB/FH4500. 32h w/QR
Spokes	DT Swiss Champion	14g/2.0mm stainless. 12mm silver brass nipples
Rims	Alex R390	32h. 700c. Black
Tires	Continental Ultra Sport	700c x 28mm. Steel bead. Black

Pedals not included

# Cross-Check™ Frameset

The Cross-Check is a great bike. It was the third frame we ever offered, and we offered it as a complete bike a year after the introduction of the frame. Neither the frame nor the component spec of the bike have changed much since we introduced it almost a decade ago because...well, why should it? We have made a few changes and updates over the years when those changes were either necessary or just plain a good idea. For instance, this year we've added mid-blade eyelets to the fork for mounting a front rack. This isn't a touring bike per se, but it will handle lighter touring loads, and a front rack can make that easier.



But that begs the question: what is this bike for? It's a cyclocross bike by category, but we try to design a lot of versatility into our stuff. You can build this frame with gears or as a singlespeed or fixed-gear. You can ride it on the road or off. It's got lots of space for fat tires and for fenders. It does as good a job getting you across the country as it does getting you across town.

For the complete bike we picked out components that set the standard for our other completes, stuff that works well and doesn't dent your piggy bank too bad. The frame is comfy and tough as nails, and versatile too. We continue to hear from people who have made the Cross-Check their default go-to bike simply because it performs so astonishingly well. It's one of the best riding, most versatile bikes around. Now you've heard about it. Go try one.

## Cross-Check Specifications:

**tubing:** Surly 4130 CroMoly steel. Main triangle double-buttet. TIG-welded

**Rear dropouts:** Semi-horizontal dropouts give you singlespeed compatibility and wheelbase adjustability. Adjuster screws are included to keep your wheel in the right place for optimal shifting if you go with derailleurs. Our Gnot-rite spacing (132.5mm) allows you to run 130mm road hubs and 135mm MTB hubs

**Braze-ons:** Bosses front and rear to take cantilever or linear-pull brakes, eyelets at the dropouts, rear rack bosses, dual water bottle mounts, downtube shifter bosses, fully threaded through-blade fork eyelets for a front rack

**Seatpost diameter:** 27.2mm

**Seatpost clamp:** 30.0mm Surly stainless, included

**Headset/stem:** 1-1/8" threadless

**Bottom bracket:** 68mm wide, standard English threaded 1.37" x 24t

**Tire clearance:** Fatties Fit Fine (FFF) stays and our beautiful slope-crowned custom fork provide room for tires up to 700c x 45mm, or about 700c x 40mm with fenders. Largest possible tire size depends on tire, rims, axle location in the dropouts, and other factors, but still, you can run pretty damn big tires

**Chainring clearance:** Manipulated stays so you can fit the size rings you want. Go nuts

**Color:** Robins Egg Blue or Gloss Black

**Weight:** 56cm = 2200g (4.88 lb)

**Fork:** uncut = 1106g (2.4 lb)

# Cross-Check™ Complete



## Component Sizing:

Size	Stem Length		Stem Angle** degrees	Bar Width c-t-c		Crank Length mm
	inches	mm		inches	mm	
<b>42cm</b>	2.8	70.0	83.0	15.7	400.0	170.0
<b>46cm</b>	3.1	80.0	83.0	15.7	400.0	170.0
<b>50cm</b>	4.1	100.0	97.0	16.5	420.0	170.0
<b>52cm</b>	4.1	100.0	97.0	16.5	420.0	170.0
<b>54cm</b>	4.1	100.0	97.0	17.3	440.0	175.0
<b>56cm</b>	4.1	100.0	97.0	17.3	440.0	175.0
<b>58cm</b>	4.7	120.0	97.0	17.3	440.0	175.0
<b>60cm</b>	4.7	120.0	97.0	18.1	460.0	175.0
<b>62cm</b>	4.7	120.0	97.0	18.1	460.0	175.0

See page 43 for a complete Cross-Check frame geometry grid.

\*\*Stems can be flip-flopped to customize angle.

**Weight:** 54cm = 24.6 lb (11.16kg)

**Color:** Robins Egg Blue or Gloss Black

**Component sizing and spec may vary.**

## Bike Specifications:

Component	Type	Description
Frame	Surly Cross-Check	Surly 4130 CroMoly steel. Main triangle double-butted. TIG-welded. Rear rack bosses
Fork	Surly Cross-Check	100% CroMoly, lugged + brazed crown. 1-1/8" threadless steerer. Uncut
Headset	Ritchey Logic Comp	1-1/8" threadless, w/30mm spacers (+ 10mm clamp-on hanger = 40mm stack total). Black
Stem	Kalloy AS-008	1-1/8" threadless. Forged. Black
Handlebar	Salsa Moto Ace Bell-Lap	26.0mm clamp diameter. Black
Handlebar Wrap	Co-Union Cork Mix	Feels good. Black
Brake Levers	Tektro	RL340 standard levers on 52–62cm sizes, RL341 small hand levers on 42–50cm
Brakes	Tektro 992A	Black
Cable Hanger, front	Tektro	1271A. Includes routing noodle. Black
Cable Hanger, rear	Surly	Stainless w/adjuster. Silver
Shift Levers	Shimano Bar-end type	SL-BS77. 9-speed
Front Derailleur	Shimano Tiagra	FD-4500 Double
Rear Derailleur	Shimano Tiagra	RD-4500-GS Mid-cage
Crankset	Andel	Forged arms, Silver aluminum, granny ring compatible. 110mm BCD rings, 36 & 48t, ramped & pinned, Black
Pedals	NOT INCLUDED	NOT INCLUDED
Bottom Bracket	Shimano	BB-UN54 68 x 113mm
Seatpost	Kalloy SP-342	27.2 x 300mm. Black
Seatpost Clamp	Surly Stainless	Silver
Saddle	WTB SST	Vinyl. CroMoly rails. Black
Cassette	Shimano Tiagra	HG-50 9-speed 12-13-14-15-17-19-21-23-25t
Chain	SRAM PC-971	9-speed
Hubs	Shimano Deore	HB/FH590 32h, 100mm OLD front, 135mm OLD rear. Black
Spokes	DT Swiss	Stainless Steel, 14g/2.0mm w/12mm silver brass nipples
Rims	Alex	DA16. 32h x 700c. Black
Tires	Ritchey SpeedMax Cross	700c x 32mm Wire bead. Black wall
Tubes	Cheng Shin	Standard Presta valve 700c x 32mm

Extras: Clear chainstay protector. Die-extruded cables with anti-rattle donuts. Full CPSC reflector kit. Generic owner's manual

# Steamroller™ Frameset

We offer the Steamroller as a frameset and also as a complete bike. The frame, like all our frames, is made of 4130 CroMoly steel. Steel is springy and durable, providing a ride feel you don't get from aluminum or carbon fiber, at a price titanium can't match. True, our frames are not the lightest out there, but then they're not supposed to be. Instead, they're a balance of excellent ride quality and durability.



It was designed as a dedicated fixed-gear, but its geometry is closer to a road bike than a track bike. It'll take tires up to about 38mm. It's got nothing in the way of braze-ons except a set of water bottle cage mounts. You could add front and rear brakes and a freewheel if you really want, but you'll need to use full length rear housing.

This year we changed the component spec of the complete bike. We gave the Steamroller big shoes, a wide upright-ish bar, brakes, and we chose a gear ratio more suitable to paths as well as roads. It sports Surly hubs (the rear is outfitted with our fixed cog and lockring, and is threaded on the other side for a singlespeed freewheel should you want to run one) and our new Open Bar handlebar, in addition to a selection of components designed to work well and love you long time without punching you in the wallet.

As you've probably noticed, there are a whole bunch of fixed-gears out there nowadays, most of them either actual track bikes (not especially suited to streets and definitely not suited to paths) or modified fixed-gears that people ride like BMX bikes. We made ours more like an all terrain fixed-gear, an updated version of bikes from the old daze, long ago, when all bikes were fixed-gears, when people raced on flat oval dirt tracks, and when bad roads were the norm. The Steamroller is right at home in these conditions. What won't it do? Bar spins.

## Steamroller Specifications:

**Tubing:** Surly 4130 CroMoly steel. Main triangle is double-butted. TIG-welded

**Rear dropouts:** Investment cast Surly track dropouts, 120mm spaced

**Brake compatibility:** Standard reach post-mount road calipers, but there are no stops for housing

**Braze-ons:** None, baby. Pure. OK, we put one set of water-bottle mounts on the seat tube 'cause we're not camels

**Seatpost diameter:** 27.2mm

**Seatpost clamp:** 30.0mm Surly stainless, included

**Headset:** 1-1/8" threadless

**Bottom bracket shell:** 68mm wide, threaded English 1.37" x 24t

**Tire clearance:** Room for tires up to 700c x 38mm. Individual tire and rim combos affect tire clearance, but figure on being able to use tires up to 32mm with fenders (p.s. use clip-on fenders)

**Chainring clearance:** Heavy manipulation of the chainstays gives room for a 50t ring while maintaining chainline. Track crank-compatible

**Color:** Meth Teeths Gray-Green

**Weight:** 56cm = 2,000g (4.5 lb)

**Fork:** uncut = 850g (1.9 lb)

# Steamroller™ Complete



## Component Sizing:

Size	Stem Length		Stem Angle	Hbar Width c-t-c		Crank Length
	inches	mm	degrees	inches	mm	mm
<b>49cm</b>	4.3	110	7	26.2	666	165.0
<b>53cm</b>	4.3	110	7	26.2	666	165.0
<b>56cm</b>	4.7	120	7	26.2	666	165.0
<b>59cm</b>	4.7	120	7	26.2	666	170
<b>62cm</b>	5.1	130	7	26.2	666	170

\*\*Stems can be flip-flopped to customize angle

See page 44 for a complete Steamroller frame geometry grid.

**Color:** Meth Teeths Gray-Green

**Component sizing and spec may vary.**

## Bike Specifications:

Component	Type	Description
Frame	Surly Steamroller	Surly 4130 CroMoly steel. Main triangle double butted. TIG-welded
Fork	Surly Steamroller	100% CroMoly, lugged & brazed. 1-1/8" threadless steer tube
Headset	Ritchey Logic Comp	1-1/8" threadless, w/30mm spacers. Black
Stem	Kalloy AS-009	1-1/8" threadless. Forged. 25.4mm clamp. Black
Handlebar	Surly Open Bar	CroMoly. No rise. 666mm width. Black
Grips	Velo Kraton	Feels good. Black. 130mm
Brake Levers	Tektro MT2.1	Front & rear
Brake Calipers	Tektro R538	Front & rear calipers. Black
Crankset	Andel	Forged arms. 44t, 3/32" aluminum chainring. Black
Bottom Bracket	T.H.C.	68 x 103mm
Seatpost	Kalloy - SP-248D	27.2mm Black
Seatpost Clamp	Surly Stainless	Black stainless steel
Saddle	WTB SST	Vinyl. CroMoly. Black
Cog	Surly fixed-gear	19t, 3/32" Surly locking included (f/w not included)
Chain	SRAM	PC-830
Hubs	Surly	32h, 120mm OLD fixed/free rear. Black
Spokes	DT Swiss	14g. Black. 12mm Silver brass nipples
Rims	Alex DA-22	700c, 32h. Black
Tires	Continental Contact	700c x 32mm. Black

Pedals not included

# Pugsley™ Frameset

By now you know that Pugsley was created to go where standard 'all terrain' bikes flounder. The floatation and traction afforded by large-volume, low-pressure tires can get you over and through otherwise unrideable terrain, such as sand, mud, wet rocks and roots, ice, and many kinds of snow. Wide, low-pressure tires are easier than standard tires on whatever terrain you pass over because they don't dig in as easily.



The Pugsley frame has horizontal rear dropouts with a derailleur hanger. You can set it up with derailleurs or an internally geared hub, or set it up as a singlespeed or fixed-gear. This isn't just a nice option. In certain situations, extra weight and the potential for a complex part to fail isn't just a pain. It can be deadly serious business. The stock fork accepts a 135mm rear mountain hub, just like the frame. This makes it easier to install and remove the wheel (a big tire on a big rim benefits from a wide opening), but more to the point also allows front and rear wheel interchangeability. This means you can have another full gear cluster, a singlespeed or a fixed-gear wheel option should something go wrong with your freehub body or derailleurs. In other words, it's one more option for getting you back out from whatever situation you've gotten yourself into.

We have until now offered the Pugsley only as a frameset, but we're now offering a complete bike option. Like our other complete bike models, it sports a nice mix of components chosen for their durability, affordability, and suitability to the task at hand, which is to say it'll get you out there, off the beaten path, and back under your own power, hopefully with enough extra cash to buy a round at the bar when you're done. Cheers to that.

## Pugsley Specifications:

**Tubing:** Surly 4130 CroMoly steel. Main triangle double-buttet. TIG-welded

**Rear dropouts:** Surly horizontal dropouts with derailleur hanger, 135mm-spaced, offset 17.5mm

**Brake compatibility:** 51mm IS disc mounts (on the frame and fork) or traditional cantilever-type rim brakes (120mm spaced, for use with Large Marge rims)

**Braze-ons:** Cantilever bosses with removable pivots, dual water bottle mounts, toptube cable housing guides for use with continuous housing, fender and rack eyelets

**Seatpost diameter:** 27.2mm

**Seatpost clamp:** 30mm Surly stainless, included. Silver

**Headset:** 1-1/8" threadless

**Front Derailleur:** E-type

**Bottom bracket shell:** 100mm wide, 1.37" x 24t

**Chainring clearance:** Compact triple: 22-32-44t

**Fork:** Suspension-corrected (100mm travel). 447mm axle to crown, tapered straight blade, 4130 CroMoly. 51mm IS rear disc mount and removable cantilever pivots spaced 120mm. 135mm-spaced dropouts, 17.5mm offset

**Color:** Snowblind

**Weight:** 18" = 2,570g (5.6 lb)

**Fork:** uncut = 1.114g (2.52 lb)



# Pugsley™ Complete



## Component Sizing:

Size	Stem Length inches	mm	Stem Angle degrees	Head Tube Width c-t-c inches	mm	Crank Length mm
16"	3.5	90	7	26.0	660	170
18"	3.9	100	7	26.0	660	175
20"	4.3	110	7	26.0	660	175
22"	4.7	120	7	26.0	660	175

See page 45 for a complete Pugsley frame geometry grid.

**Color:** Snowblind

**Component sizing and spec may vary.**

## Bike Specifications:

Component	Type	Description
Frame	Surly Pugsley	Surly 4130 CroMoly steel. Main triangle double butted. TIG-welded
Fork	Surly Pugsley 135mm O.L.D.	Surly 4130 CroMoly steel. TIG-welded. 1-1/8" threadless steer tube, uncut
Headset	Ritchey Logic Comp	1-1/8" threadless, 30mm spacers. Black
Stem	Kalloy AS-008	1-1/8" threadless. Forged. 25.4mm clamp
Handlebar	Salsa MotoAce	660mm. 17". Black
Grips	Velo Kraton	Black. Like your heart
Brake levers	Avid FR5	Black.
Brakes	Avid BB&	Cable-actuated disc. 160mm rotor
Crankset	TruVativ Hussefelt	22/32/44t. Black
Bottom Bracket	TruVativ Howitzer	100mm shell width
Seatpost	Kalloy SP-342	27.2 x 350mm. Black
Seatpost Clamp	Surly Stainless	30.0mm. Black
Saddle	WTB SST	CroMoly rails, vinyl skin. Black
Cassette	Shimano	HG-61. 9 speed. 11-12-14-16-18-21-24-28-32t
Chain	SRAM	PC-971
Front Hub	Surly New model	QR. 32h. 135mm. Threaded for SS freewheel. Black
Rear Hub	Shimano Deore	FH-M525. QR. 32h. Black
Front Derailleur	Shimano SLX E-Type	FD-M660. Topswing, dual pull
Rear Derailleur	Shimano Deore	RD-M591 SGS Top Normal. Black
Shifters	Shimano Deore	Black
Rims	Surly Large Marge DH	32h. Black w/machined sidewalls
Spokes	DT Champion	14g/2.0mm straight gauge stainless. 12mm silver brass nipples
Front Tire	Surly Larry	3.8" Black
Rear Tire	Surly Endomorph	3.7" Black
Tubes	Surly Toob	Big. Black. Butyl. Floats small dogs easily

# Long Haul Trucker DeLuxe™ Frameset

The fact is, you can't ride your bike everywhere. Sometimes if you want to take your bike along you need a convenient way to get it there with the least amount of hassle, expense, and potential for damage.

For a couple years we offered the Travelers Check, a travel frame based on our Cross Check model.

It could be split in two via S&S Machine Company's BTCs (bicycle torque couplings), better known as S&S Couplers, machined stainless steel pieces brazed into the top and down tubes. They add a small bit of weight (less than 8 oz/227g per frame), but result in a bike that can be packed into a case for relatively easy transport.

When you put it all back together, you have a regular bike, your bike, safe and solid.

The Travelers Check was a great bike for lots of people, but despite its versatility it had some drawbacks as an ideal travel bike. Some found the wheel size problematic. 700c wheels do not fit into an airline-regulation maximum size hardcase without deflating the tires, and even then it's a tight fit. As well, many people use a travel bike for touring far away lands, panniers fully loaded with clothes, cookware, camping equipment, and mousse, and wanted a frame designed for this purpose.

It isn't really feasible for us to offer two S&S coupled frames so we're replacing the Travelers Check with the Long Haul Trucker DeLuxe. As you may know, our Long Haul Trucker is a true touring frame. The LHT DeLuxe is a Long Haul Trucker with S&S's new, lower profile couplers, and the frame uses 26" wheels. Hey!

It should go without saying that owning such a bike brings some responsibilities on your part. You will need the basic tools and know-how to safely remove and reinstall your wheels, your handlebar or stem, your pedals, possibly your fork (especially on larger frames). Be sure and visit S&S Machine's website ([sandsmachine.com](http://sandsmachine.com)). Their story, their recommendations for care of your S&S Couplers, and their own reasons for why a frame with S&S Couplers is good for you can all be found there.

## Long Haul Trucker DeLuxe Specifications:

**Tubing:** Surly 4130 CroMoly steel. Main triangle double-budded. TIG-welded

**Rear dropouts:** Vertical, 135mm spaced

**Brake compatibility:** Linear-pull or traditional cantilever

**Braze-ons:** Upper bosses and dropout eyelets for racks front and rear, fender eyelets, chainstay spare spoke holder, pump peg, downtube lever bosses, 3 sets of H<sub>2</sub>O cage bosses, rear housing stop for canti brakes, housing stops for brakes and derailleurs, S&S Couplers

**Seatpost diameter:** 27.2mm

**Seatpost clamp:** 30mm Surly stainless, included

**Headset:** 1-1/8" threadless

**Front Derailleur Clamp Diameter:** 28.6mm

**Bottom bracket shell:** 68mm wide, 1.37" x 24t

**Chainring clearance:** 42/53t double, 38/52/56t triple (max. tooth size)

**Tire Clearance:** Fits tires up to 26 x 2.1" with room for fenders

**Fork:** 4130 CroMoly, lugged and brazed, tapered curved blades with lowrider rack eyelets

**Color:** Midnight Blues

**Weight:** 56cm frame = 2,903g 6.4(lb) **Fork:** uncut = 1020g (2.25 lb)

See page 40 for a complete Long Haul Trucker DeLuxe frame Geometry grid.



# Troll™ Frameset

The Troll's geometry is that of a 26" wheeled mountain bike, but it's unlike most mountain bikes. It's got ample clearance for 28/38/50t mountain triple chainrings and room for big tires, up to 26 x 2.7". The gusseted front triangle, with its sloping toptube, provides ample standover clearance even when running high-volume rubber. Run a 100mm travel suspension fork if you like, or you might choose to leave the Troll's fork in place. Like the frame, it's made of 4130 CroMoly steel, providing a stout yet resilient, point-and-shoot ride.



There are a lot of notable features, like full line guides for derailleur and brake housing, fender eyelets, and disc and rim brake mounts. Both the frame and fork are equipped with mounts for front and rear racks, and the design allows the use of racks, fenders and disc brakes all at the same time.

It's worth taking a look at the rear dropout area. Similar to our Pugsley and Karate Monkey dropouts, the Troll has horizontal, rear-load dropouts with a derailleur hanger. Additionally, however, there's a dedicated area for anchoring a Rohloff hub OEM2 axle plate, and we've included threaded holes in the thick plate material for installing Surly trailer-mounting nuts or B.O.B. Nutz.

Like many of our models, the Troll is available as a frameset or as a complete bike. Use it as a mountain bike, as a cruiser, commuter or touring rig. Use it as your go-to utility tractor. Try out different tires or handlebars. Add some racks and gears or strip it down to a singlespeed drivetrain. Take it camping, ride it to the grocery store or session on your favorite single-track. Build it up, ride it for a while, then reinvent it.

## Troll Specifications:

**tubing:** Surly 4130 CroMoly steel. TIG-welded. Main triangle double-butted

**Seatpost diameter:** 27.2mm

**Seatpost clamp:** 30.0mm Surly stainless, included

**Headset/stem:** 1-1/8" threadless

**Bottom bracket:** 73mm shell width, threaded standard English (1.37" x 24t)

**Braze-ons/extras:** Full-length housing line guides for derailleurs and brakes; 2 sets of water bottle cage mounts, removable post cantilever pivots; upper seatstay threaded barrels, mid-and low-blade fully threaded through-blade fork eyelets; threaded holes for racks, fenders and trailer mounting nuts; Rohloff OEM2 axle plate mounting slot

**Brake compatibility:** Disc and rim brake compatible. Note: rear disc brake is limited to 165mm maximum rotor diameter and requires the use of Surly caliper adapter

**Tire clearance:** 26 x 2.5" with rear wheel fully forward. Clearance for 2.7" tire with wheel farther back

**Chainring clearance:** 28/38/50t

**Hub compatibility:** 100mm O.L.D. front, 135mm O.L.D. rear

**Fork:** TIG-welded 4130 CroMoly, 100mm suspension corrected, tapered straight blade. Low- and mid-blade fully threaded through-blade rack eyelets; fender mount eyelets at dropout; 1-18" x 260mm threadless steer tube, 51mm disc mount, removable cantilever pivots, line/housing guides

**Color:** Agent Orange

**Weight:** Not available at time of printing

# 1x1™ Frameset

Here you find the venerable 1X1, the frame whose name is synonymous with singlespeeds the same way people call facial tissue Kleenex. The 1X1 was designed for 26" wheels, big tires, and single gear and cog drivetrains, like freewheeled singlespeeds, fixed-gear, and even internal geared hubs. No derailleur hanger, no housing stops or line guides for derailleurs. The 1X1 is simple, durable and beautiful.



It's made of Surly 4130 CroMoly, with a custom double-butted main triangle and triple-butted fork blades for a tough yet responsive, lively ride. Adding to that ride feel is its geometry which is, well, simple. It rides like a mountain bike. The chainstays are heat treated to add to its durability. It still has rim brake pivots. They're removeable in case you want to clean up the look when you run disc brakes.

This year we've updated some of its design features, something we've done rarely over its life. We lowered the toptube a bit to increase stand-over clearance and also made it compatible with 100mm suspension forks. As well, the rear disc caliper mounting plate has been redesigned to allow easier rear wheel removal and installation...no more loosening the adapter bolts to allow the rotor to clear the caliper.

The 1X1 rides like a bike, without a lot of fussin' and fightin'. This is a frame you keep, a frame you use for years and years. It has been around since the very early daze of Surly, and it remains one of our favorites.

## 1x1 Specifications:

**Tubing:** 4130 CroMoly steel. Main triangle double-butted. TIG-welded

**Rear dropouts:** Investment cast Surly track dropouts, 135mm spaced

**Braze-ons:** 51mm disc tabs and removable cantilever bosses front and rear, rear brake toptube housing stops, seatstay mounted disc housing guides, fender eyelets front and rear, and dual water-bottle mounts

**Seatpost diameter:** 27.2mm

**Seatpost clamp:** 30.0mm Surly stainless, included

**Headset:** 1-1/8" threadless

**Bottom bracket shell:** 73mm wide, threaded English 1.37" x 24t

**Tire clearance:** Room

**Fork:** Suspension corrected for 100mm travel suspension fork. 100% CroMoly

**Color:** Cash Black

See page 47 for a complete 1x1 frame geometry grid.

# Forks



## Karate Monkey

The Karate Monkey rigid fork replaces 80mm suspension forks designed for use on 29" wheeled bikes. It features 51mm IS disc mounts, removable canti pivots, 1-1/8" threadless steerer, tapered straight blades and a black powdercoat finish.

<b>Axle-to-crown:</b>	468mm
<b>Rake:</b>	43mm
<b>Steerer:</b>	260mm
<b>Weight:</b>	2.6 lb (1.2kg) uncut



## Troll Fork

The Troll fork is just like the one that comes on our new Troll frame, a 26" wheeled fully geared utility bruiser and cruiser. The Troll fork replaces 100mm travel suspension forks. Like all our forks, it's constructed of CroMoly steel and sports rim brake pivots (removable) as well as a 51mm disc caliper mount. Unlike our other forks it's designed to accept a rack while using a disc brake, via through-blade threaded mounts in two places on each fork blade. Fender eyelets too. Steerer is 1-1/8" threadless. Finish is black powdercoat.

<b>Axle-to Crown:</b>	453mm
<b>Rake:</b>	40mm
<b>Steerer:</b>	260mm
<b>Weight:</b>	N/A



## Big Dummy

We designed the Big Dummy fork to handle the rigors of hauling you and your precious cargo. Its tapered 4130 CroMoly straight blades provide the durability needed for a cargo bike without delivering a jackhammer ride. The Big Dummy fork features 51mm IS disc mounts, removable canti pivots, 1-1/8" threadless steerer, disc brake line/housing guides, single dropout eyelets, 80mm suspension-corrected and a black powdercoat finish.

<b>Axle-to-crown:</b>	425mm
<b>Rake:</b>	43mm
<b>Steerer:</b>	260mm
<b>Weight:</b>	2.9 lb (1.3g) uncut



## Cross-Check

Our lugged and brazed Cross-Check/Travelers Check fork has room for 700c x 45mm tires and fenders. It's made from 4130 CroMoly steel and features fender eyelets at the dropouts, cantilever brake pivots, and now has through-leg mid-blade eyelets for mounting a rack. The eyelets are threaded 5 x 1mm and located 165mm up from the axle. We offer it in 1" and 1-1/8" threadless steertube versions. Finish is black powdercoat.

<b>Axle-to-crown:</b>	400mm
<b>Rake:</b>	44mm
<b>Steerer:</b>	300mm
<b>Weight:</b>	1" = 2.10 lb (.97kg) uncut 1-1/8" = 2.30 lb (1.00kg) uncut



## Instigator

The Instigator rigid fork replaces 100mm travel suspension forks. It is constructed of thick-walled, single-buttetted 4130 CroMoly, so it will hold up under pressure. It features a 51mm IS disc mount, removable canti pivots, 1-1/8" threadless steerer and a black powdercoat finish. If you want to run fatties in this fork, go ahead. You can easily wedge a 2.7" tire between those straight, tapered (31.8-28.6mm) blades. Tandem and dirt jump rated. How many other forks can say that? One or the other, of course. Not meant for dirt jumping on tandems.

<b>Axle-to-crown:</b>	447mm
<b>Rake:</b>	43mm
<b>Steerer:</b>	260mm
<b>Weight:</b>	3.1 lb (1.4kg) uncut

## 1x1



We now have three 1x1 forks available. First, the original: 80mm suspension 'corrected,' rim brake pivots, fender eyelets, and nothing else. Next, the same thing (with rim brake pivots) with a 51mm disc mount and line guides. The third version has the rim brake mounts, the disc caliper mount, and the line guides but it is corrected for frames designed for 100mm suspension forks. All are triple butted and take real big tires...you can stuff 2.7" tires between the blades and have room to spare. All are made from 4130 CroMoly tubing, all have 1-1/8" threadless steerers and all are powdercoated black.

### All:

<b>Rake:</b>	45mm
<b>Steerer:</b>	260mm

### 80mm VERSION:

<b>Axle-to-crown:</b>	413mm
<b>Weight, canti only:</b>	2.34 lb
<b>Weight, disc:</b>	2.34 lb (1.06kg)

### 100mm VERSION:

<b>AXLE-TO-CROWN:</b>	453mm
<b>Weight, 100mm:</b>	N/A

## Long Haul Trucker



Designed for the front end of our Long Haul Trucker touring frame, this fork sports a beautiful investment cast sloping crown and dropouts brazed to curved blades, dual eyelets at the dropouts for fenders and a rack, threaded bosses brazed into the fork blades for mounting a lowrider rack (165mm up from axle), and cantilever studs which work with canti or linear-pull brakes. It has a 1-1/8" threadless steerer, and you have the option of choosing from two sizes. Black powdercoat finish.

<b>Axle-to-crown, 700c:</b>	390mm
<b>Axle-to-crown, 26":</b>	376mm
<b>Rake:</b>	45mm
<b>Steerer:</b>	26" = 300mm for 42-54cm frames, 380mm for 56-62cm 700c = 320mm
<b>Weight:</b>	26" (300mm steerer) = 2.1 lb (.97kg) uncut  700c = 2.30 lb (1.0kg) uncut



## Pugsley

We now offer three versions of the Pugsley fork. All are CroMoly steel and allow ample clearance to fit a whopping 4" tire. Two versions are spaced 135mm between the dropouts. Of these, one is offset to match the the Pugsley frame, and the other is non-offset. The third fork is spaced for a standard 100mm front hub.

All three have 51mm disc caliper mounts. The two 135mm versions require the use of a rear caliper adapter if using disc brakes. The 100mm version works with a standard front caliper adapter. All three forks also have removable cantilever pivots, spaced 120mm apart (specifically for use with our 65mm Large Marge rim). V-brakes are unlikely to work because the arms are not tall enough to allow the cable to clear the tire, so use cantilevers only in this case. All three forks sport fender eyelets, cable housing guides, 1-1/8" threadless steerer, and are powder-coated black.

<b>Axle to crown:</b>	447mm
<b>Rake:</b>	43mm
<b>Steerer:</b>	260mm
<b>Weight:</b>	2.5 lb (1.14kg) uncut



## Pacer

This is the same lugged and brazed fork that we provide with our Pacer road frameset. It will allow you to run 28mm tires with fenders or 32mm tires without. Many short-reach caliper brakes will work, but we can't guarantee 100% compatibility. Standard-reach (47-57mm) calipers are recommended. This fork comes with single-eyelet dropouts, 1-1/8" threadless steerer and a black powdercoat finish.

<b>Axle-to-crown:</b>	371mm
<b>Rake:</b>	45mm
<b>Steerer:</b>	300mm
<b>Weight:</b>	2.2 lb (1.0kg) uncut



## Steamroller

Our Steamroller fork, designed around our fixed-gear frame, is brazed with a flat crown that is drilled to accept a standard-reach (47-57mm) caliper brake. It has clearance for 700c x 38mm tires. There are no eyelets at the dropouts. Available with 1 or 1-1/8" threadless steerer.

<b>Axle-to-crown (1" steerer):</b>	368mm
<b>Axle-to-crown, 1-1/8":</b>	375mm
<b>Rake:</b>	38mm
<b>Steerer:</b>	300mm
<b>Weight:</b>	1" = 1.9 lb (.9kg) uncut 1-1/8" = 2.20 lb (1.0kg) uncut



# Mr. Whirly Crank



The easiest way to get to know Mr. Whirly is as a complete crankset. We offer completes as mountain triple for standard frames, as mountain triple for Pugsley frames, and in a singlespeed version. Triples use 44/32/22t aluminum rings on a 94mm BCD spider, and the singlespeed sports a long-wearing 33t Surly stainless steel chainring on a 94mm BCD spider. Completes are available in two arm lengths and are available only in black.

Component pieces offer more variety. Armsets are forged AL-7075 aluminum and they're available in five sizes and two colors. All three spiders share the 58mm BCD drive arm mounting interface and are available in three common sizes to cover a wide range of gearing options. Spiders are aluminum and also come in silver or black. Spindles are CroMoly steel, available in three lengths. The longest fits Pugsley frames and other frames with 100mm BB shells. The other two fit standard 68 and 73mm BB shells. One provides a 50mm chainline, standard for most 135mm hubs, while the other provides a 47.5mm chainline, the older 135mm hub standard. We also offer bearing sets and all the original equipment hardware, even the hardened bolts we spec. We could have used cheaper stuff, but where would that leave you?

Set Mr. Whirly up for the riding you do. Replace bits if they break instead of replacing the whole crank. Mountain bike with it. Tour with it. Commute with it. Mr. Whirly isn't stingy with his love.

## Cranksets:

**Mountain triple:** 22/32/44t rings (aluminum) on 94mm spider. Spindle for 68/73mm shells. 170 or 175mm. Black

**Pugsley triple:** 22/32/44t rings (aluminum) on 94mm spider. Spindle for 100mm shell. 170 or 175mm. Black

**Singlespeed:** 33t Surly stainless steel ring on 94mm spider. Spindle for 68/73 shells. 175 or 180mm. Black

## Component Bits:

**Armsets:** 165, 170, 175, 180 or 185mm. Silver or Black

**Spiders:** 58/94mm, 58/104mm, 58/110mm BCD. Silver or Black

**Spindles:** All Mr. Whirly spindles are CroMoly. Available in:

- Short to provide 47.5mm chainline on 68 & 73mm BB shells
- Medium to provide 50mm chainline on 68 & 73mm BB shells
- Mondo to fit 100mm (Pugsley) BB shells

**Extras:** All small hardware bits, bearings and bearing spacers are available separately. Black or Silver as applicable

# Stainless Steel Chainrings

Most chainrings on the market are made from aluminum. Although it's light and stiff, aluminum wears out fairly quickly in the high-friction world of a chain-driven bicycle drivetrain. Our chainrings are made from 304 grade stainless steel. They're ideal for singlespeed, fixed-gear, or tandem timing chain applications in part because stainless doesn't wear as fast as aluminum (and of course it doesn't rust either). This is of some importance on a singlespeed system, where the chainwear isn't shared by other chainrings. Long-wearing parts mean more time on your bike and more money in your pocket. Our stainless chainrings are not ramped or pinned for shifting assistance.

**Color:** Natural Silver

**Compatibility:** Designed to work with  $3/32$ " (derailleur type) chains. Please note that many 10-speed and some 9-speed chains may fit tightly at first.

**Sizes:** **94mm** BCD x 30, 31, 32, 33, 34, 35 and 36t

**104mm** BCD x 32, 33, 34, 35 and 36t

**110mm** BCD x 34, 35, 36, 38, 39, 40, 42, 44, 46, 47, 48, 49t and 50t

**130mm** BCD x 38, 39, 40, 42, 44, 46, 47, 48, 49 and 50



# Cassette Cogs

Our cassette-type cogs are designed to fit on standard Shimano-compatible freehub bodies. These cogs have a tall tooth profile that is essential for preventing chain skip from the extra torque a singlespeed drivetrain encounters. In addition to being a stellar SS cog, the cog base width (where it contacts the freehub body) is 4.35mm, so you can stack a few of them up and use a 9-speed shifter for a simplified multi-speed drivetrain. This width also prevents it from ruining the freehub body as a result of digging grooves into it like skinny stamped cogs have a tendency to do. Surly cogs are machined from SCM415 CroMoly steel, then heat-treated for toughness and chrome-plated for surface hardening and enhanced chain lubricity. Our cogs will work with **6-9-speed**  $3/32$ " chains, although we recommend the inherently updated quality of an 8- or 9-speed chain. They are available in every increment from 13-22t, so you can select that perfect gear.



# Track Cogs

Our track cogs are designed to spin onto standard ISO-threaded ( $1.37$ " x 24tpi) hubs, so they will work with most English, Italian and Japanese hubs, including the Surly New track hubs. The thread base is 7.4mm wide for maximum thread engagement while maintaining enough room for a track lockring to thread on. Like our cassette-splined cogs, these are made from machined, heat-treated and chrome plated SCM415 CroMoly steel, so they are tough and long lasting. Track cogs are available in either  $3/32$  or  $1/8$ " tooth thicknesses and in every size from 13-22t.



# 1x1 Singleator™

Midwest singlespeed legend Pete Geigle developed the 1x1 Singleator so you singlespeed virgins could taste the pure mountain biking experience without spending too much cash. Installing horizontal dropouts on your frame can be difficult and/or expensive, particularly if your steed is of the aluminum variety. The Singleator mounts right up to your derailleur hanger and provides a simple, effective, and adjustable means of tensioning the excess chain slack found in vertical dropout singlespeed drivetrains.

The Singleator features a triple-sealed spring, large cog capacity, chain guides, fully-adjustable chain line, floating pulley, and a stainless steel pivot bushing. The main body is forged, not machined so it's strong. We've gone with an 11-tooth pulley for smooth, quiet operation. And it now works with both 1/8" (BMX) and 3/32" (geared bikes) chains. Beware impostors; the Singleator is the granddaddy and outperforms all others.

**Colors:** Black or Silver



## Singleator Tool

The production of our stainless steel chainrings generates a lot of scrap material, so we decided to use some of it to make the Singleator Tool. This polished and laser-etched tool sports an 18mm open-end wrench on one end...for adjusting the tension on a Singleator, and a bottle opener on the other end. It's compact (because you don't need to put a lot of tension on a Singleator spring), so it easily fits in a tool kit, in a pocket or on a key chain.



## Single-Speed Spacer Kit

Got a rear wheel from a geared bike collecting dust in your garage? Maybe it's time you gave it some new life as a singlespeed wheel. We now offer a singlespeed spacer kit that allows you to use singlespeed cassette cogs on the freehub body of your multi-speed Shimano cassette-compatible hub.

With the supplied selection of anodized aluminum spacers, you can attain a perfect chainline to complement your road, track or mountain crankset. Our large-diameter stainless steel cassette lockring holds everything together and perfectly matches the outside diameter of the spacers. Plus, it matches the machined shoulder of our singlespeed cassette cogs (not included). The lockring is machined to utilize a common Shimano cassette locking tool for installation and removal. This isn't just a mix of off-the-shelf parts; we went the extra distance to give you a kit that will provide maximum functionality, durability and aesthetic value.



# New™ Hubs

We make hubs designed for singlespeed drivetrains.

All our hubs sport 'medium' flange height, and they spin on fully sealed adjustable cartridge bearings. We use adjustable bearings so you can take out the play that develops over time as they wear. All of our hubs use steel axles and hardened steel hardware, and the axle diameter and threading is a popular standard, so that it will still be easy to find replacements should the need arise or if you want to swap from solid axle to QR or vice versa.

All the current options are listed below. This year, we've added a bevy of 48-hole hubs. Bike polo anyone?



## Front Disc & Non-Disc:

Silver, 32h, solid axle, 100mm O.L.D.  
Black, 32h, solid, 100mm  
Black, 32h, quick-release, 100mm  
Silver, 36h, solid, 100mm  
Black, 48h, solid, 100mm  
Black, 32h, solid, 135mm  
(no threading or rotor mounting holes)

## Rear Non-Disc, 135mm (MTB spacing):

Silver, 32h, solid, free/free  
Black, 32h, solid, free/free  
Black, 32h, solid, fix/free  
Silver, 32h, solid, fix/free  
Black, 32h, quick-release, free/free  
Silver, 36h, solid, free/free  
Black, 48h, solid, fix/fix  
Black, 48h, solid, free/free

## Bearings:

7901 Enduro Max angular contact, full complement, adjustable cartridge

## Freewheel Threading:

English 1.37" x 24tpi

## Fixed Cog Threading:

English 1.37" x 24tpi

## Rear Disc, 135mm (MTB spacing):

Silver, 32h, solid axle, freewheel threading  
Black, 32h, solid, freewheel  
Black, 32h, quick-release, freewheel  
Silver, 36h, solid, freewheel  
Black, 32h, solid, fixed-gear threading

## Rear, 120mm (track spacing). No disc option:

Silver, 32h, solid, fixed-gear/lockring both sides  
Black, 32, solid, fix/fix  
Silver, 36h, solid, fix/fix  
Silver, 32h, solid, fixed one side/freewheel  
Black, 32h, solid, fix/free  
Black, 48h, solid, fix/fix  
Black, 48h, solid, free/free

## Rear, 130mm (road spacing). No disc option:

Black, 32h, solid, fix/free  
Silver, 32h, solid, fix/free

## Lockring Threading:

1.29" x 24tpi LH

## Axle Threading:

9 x 1mm all fronts  
10 x 1mm all rears

**Please note:** Fixed cogs and English threaded SS freewheels use the same size threads. Fixed-gear hubs have a second set of smaller diameter, reverse-direction threads outboard of the cog threads. Surly does not endorse the use of fixed-gear cogs of any kind without the use of a properly installed lockring. We know some jerk on MTBR.com said he did it and ain't been hurt yet, but lockrings are important. You have been warned. If you hurt yourself because you didn't use one, you deserve what you get.



# Dingle Cogs

Dingle Cogs are part of a different concept for fixed-gear drivetrains. Having two cogs on the back means you have more options for gear changes when the conditions demand it. For instance, say you want to ride your off-road fixie from your house to the trailhead, but your gear combo is either too high for the dirt or too low for the road. With a 17/19t Dingle on the back, pick two chainrings that are two teeth apart, like a 44t and a 42t. When you change from the outer (44:17t) gear combo to the inner (42:19t), you'll have a much better off-road gear and your wheel position will not change. This maintains effective chainstay length so you won't have to worry about having too much or too little dropout length to accommodate the gear change. The Dingle (the word is a combo of 'dual' and 'single') works great in hilly terrain both on or off-road. Like our cassette and track cogs, these are made from machined, heat-treated and chrome plated SCM415 CroMoly steel, so they are tough and long lasting.



Dingle cogs thread onto any standard ISO threaded (1.375" x 24tpi) fixed-gear hub, and like all fixed-gear cogs require the use of a lockring. In order to keep them narrow enough to work with standard fixed-gear thread width, Dingle cogs are compatible with 9-speed chains only.

## Available sizes:

17/19t, 17/20t, 17/21t

# Track Lockrings

CNC-machined from premium stainless steel...no flaking chrome or rusting. We've improved the design to increase thread contact. It's now a full 5mm thick, plus a lip (0.65mm extra) to maximize thread contact on all compatible hubs. Fits English lockring threads (1.29" x 24t LH) to work on almost all track hubs available today except Campagnolo (1.32" x 24t LH) and French (33 x 1mm LH).



# Fixxer™ Hub Converter

If it shifts, it must be broken. "Fix" it with our Surly Fixxer hub converter. The Fixxer replaces the freehub body of Shimano brand hubs and is ISO threaded to accept a fixed-gear cog and lockring, allowing you to convert a geared wheel to a true fixed-gear. A popular conversion for track racers, springtime trainers, fixed-gear commuters and messengers, the Fixxer includes all parts necessary for installation, including axle, bearing, cones, spacers, and axle nuts. Most converted hubs can be spaced 120, 126, 130 or 135mm. You'll still need to get a lockring and cog and of course a frame with appropriate dropouts.



The Fixxer works with most Shimano-branded hubs. Note that this doesn't mean hubs that accept Shimano cassettes but rather actual Shimano brand hubs. Due to variation in Shimano's F/H body-to-hubshell interface there are some Shimano hubs we know will not work. They are: all Silent Clutch, Dura Ace made before 1997 and after 2003, XTR M970/975, XTM770/775, Saint and DXR-MX70. **Color:** Silver

# Big Fat Tires: Endomorph & Larry

The whole point of a big, fat tire is to provide maximum ground contact surface area.

A tire with a lot of footprint, especially run at low pressure, can float over soft stuff like sand or packed snow instead of sinking in, and also results in greater traction. This means that you have greater control on wet, slippery stuff like tree roots. This can greatly increase where you can ride. Since they tend to float on top of the terrain instead of sinking in, a larger footprint leaves...well, less footprint.



**Endomorph**

**Larry**

The Endomorph is 3.7" (94mm) wide. Larry is 3.8" (97mm) wide. Both are designed to work with extremely wide rims, such as our 65mm Large Marge and 82mm Rolling Darryl rims. These tires (and rims) will not fit normal bicycle frames. They are simply too big. Not only are they too wide for most frames, they're also too tall. Although they're technically 26" tires (their bead seat diameter is 559mm), inflated they measure approximately 740mm (29").

The Endomorph's tread is comprised of low, small, triangular knobs connected by chevron shaped ribs. The knobs are widely spaced and taller near the sidewalls. They don't pack up with snow or mud, and the tall side knobs provide bite when cornering or when riding off camber sections. The Endomorph's chevrons and box-like profile act like a paddle to push you forward in soft conditions.

Larry's tread is a bit different. The low chevron ribs are still there, but they connect longer, dagger shaped knobs. The knobs are all the same height, so as they wrap around the casing the result is a more rounded profile compared to the Endomorph. They're also taller knobs than the ones on the Endomorph. Their shape allows them to roll smooth going forward and to dig in better laterally, meaning the sides of the knobs do more work than the rotational leading edge. All this results in greater steering control in the loose and soft conditions they're meant for. Larry is best suited for use as a front tire complementing the Endomorph, but it will also work as a rear where a taller knob is desirable, such as riding on loose gravel.

A tire's durometer (stickiness of the rubber) and wall thickness have a lot to do with its performance. Both the Endomorph and Larry are made from medium durometer (60a) rubber, allowing a balance of durability and ground-grabbing traction. Both models are available in a 120tpi casing, which is supple and conforms well to the terrain, and also in a heavier and somewhat less supple (but less expensive) 27tpi casing.

Such high volume tires require much lower than normal pressure. We've run our tires as low as 5 psi in deep snow, but 8-10 psi is generally low enough for most snow and sand riding. Want to ride on harder surfaces? Pump 'em up to 15 psi if the surface is hard but rough and up to 28 psi if you're riding pavement or smooth, hard dirt. Play around with the pressure to determine what pressure will best complement your riding style, trail conditions (or lack thereof) and your weight. A pound or two of pressure can make a big difference in how they feel and grab the ground.

## Surly Tubes

Designed for use with Endomorph or Larry tires. Presta valves with removable core. Butyl rubber. Available in 1.0 and 1.3mm wall thicknesses.

# Big Fat Rims: Rolling Darryl & Large Marge™

We offer two rim models. Both are designed to work primarily on so-called “snow frames,” with very large tires run at low pressure. This combination allows maximum traction and floatation over soft and/or slippery ground, such as packed snow, sand, wet, rooty or rocky trail, or terrain where there is no trail. Basically, such a combination allows you to ride places you simply can't on any other type of bike.

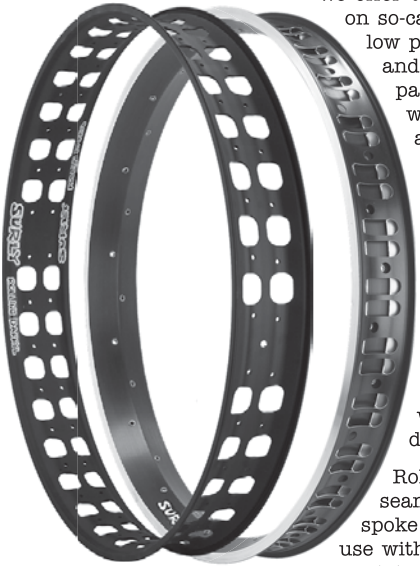

There are several versions of Large Marge. All are 65mm wide, double walled with welded seams. The Large Marge XC model is machined to save weight. The DH model is a bit heavier but also a bit less expensive. Both are available in Standard Marge and Pugsley Marge versions. Choose the Pug Marge when using these on a Pugsley or similarly offset frame. Choose the Standard Marge for unicycles, non-offset snow frames, or the rare standard frame with unusually ample clearance, such as some downhill and cruiser frames.

Rolling Darryl is a whopping 82mm wide welded seam single wall rim with an unusual 64 hole dual spoke hole pattern. Lace 32 holes asymmetrically for use with Pugsley and other offset frames. Lace 32-holes symmetrically for use with non-offset frames. Single wall construction and cutaway sections keep its weight respectable, even lower than Large Marge. Rolling Darryl is pretty specifically a snow and sand rim, where the ‘snowshoe effect’ of staying on top of the terrain is key and overbuilt durability is secondary.

Large Marge and Rolling Darryl's ETRTO (Bead Seat Diameter) is 559mm. Both are drilled for a presta valve tube. Large Marge DH Pug (offset extrusion) and standard (symmetrical) versions are available in 32 and 36 hole. Large Marge XC Pug and standard versions are available in 32-hole only. Rolling Darryl is available in 64-hole dual duty spoke drilling only. All are available in black.

**Standard Marge**



**Pugsley Marge**

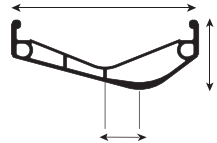

**Note: We offer special Large Marge rims that are offset-drilled to give more dish to the disc side of Pugsley wheels.**

## Large Marge Rim Strip

We had some wide rim tape manufactured by ROX specifically for Large Marge rims. These 50mm-wide synthetic cloth strips are adhesive-backed, so they'll stay in place. They won't tear or puncture, and they won't absorb moisture. One size fits all...just cut off a few centimeters when you're using them on the 24" Large Marge. **11g**

# Surly Rack™

Surly Racks are well-thought-out, durable, expedition-worthy racks that work with most panniers. While our racks aren't limited solely to heavy duty touring, that is what they were designed for.

Repairability should be a consideration for any product that will be used in every extreme, which is why the main body of our Racks is made of tubular CroMoly steel. In the rare instance that the Rack breaks, you should be able to find, even in the most remote regions of planet Earth, somebody to TIG, MIG, stick-weld, braze or solder a Surly Rack back together. An aluminum rack won't afford you the same luxury. The Racks' hardware is stainless steel.

Our height-adjustable front Rack is a lowrider/highrider design. Panniers mounted in the lowrider position provide a more stable ride, but can be a burden when riding rocky or rutted roads and trails. The upper rails provide an alternate pannier mounting position for these types of conditions. The platform above the wheel provides extra space to lash on more stuff. The front Rack mounts directly to forks equipped with a mid-blade eyelet, located approximately 165mm from the dropout eyelet. This is a standard eyelet location found on many touring-specific forks, including our Long Haul Trucker fork. We also provide hardware to securely mount a Surly Rack on forks that do not have a mid-blade eyelet...which means you can mount it on almost any rigid fork, providing there is nothing in the way.

The rear Rack is also height-adjustable, enabling it to fit a wide variety of wheel sizes while allowing you to move its center of gravity as low as possible for a more stable ride. Its wide platform has plenty of room for rack trunks, sleeping bags, tents, boxes of lima beans, or small cages full of hamsters. The stainless steel hardware we provide will enable you to fit them to most rigid 26" and 700c frames, and to forks equipped with drum, caliper, or cantilever brakes. Disc brakes and suspension are generally not compatible with our rear Racks, though there is an increasing number of frames designed to allow the use of racks and disc brakes, such as our Troll.

**Color:** Black or Silver

**Front Rack specifications:**

Tubing diameter: 10mm

Platform dimensions: 230 x 170mm

Weight: 1382g

**Rear Rack specifications:**

Tubing diameter: 10mm

Platform dimensions: 310 x 150mm

Weight: 1260g





## 1x1 Torsion Bar™

Made for us by NITTO, these wide, flat, 4130 CroMoly bruisers will give you a distinct advantage in any derby situation. With a 15° bend and 666mm width, they're also mighty comfortable. Now available in black too. Get ready to flat track!

**Color:** Silver or Black

**Clamp:** 25.4mm



## The Open Bar

The Open bar is an upright bar but not an uptight bar. It's equally suited to cruising, commuting, and even some singletrack, though it should be noted that this is not by any means a DH bar. We left it a bit flexy to take some of the harsh out of your ride. The angle makes it comfy for your wrists. The width enables loads of control. It's got plenty of room for grips, shifters and brake levers. Knurled clamp area. 4130 CroMoly steel. Available in low rise and no rise versions.

**Color:** Silver or Black

**Clamp:** 25.4mm

**Width:** 666mm

**Angle:** 53°

**Rise:** 0mm or 40mm



## Stainless Steel Cable Hanger

We couldn't find a cable hanger we liked which also fit our Constrictor seat post clamp's oversized bolt. So we made one. Long enough to eliminate kinked rear brake cables, large enough to fit over thick post clamp bolts, versatile enough to work with most other post clamps, and it's even got an adjusting barrel.



# Constrictor™ Seatpost Clamp

The Constrictor was designed specifically to end slipping seat posts. The extra-thick clamp utilizes an 8mm stainless steel bolt and accommodates a rear cantilever brake hanger, if you decide to go that route. The Constrictor is machined out of aluminum billet and black anodized. It's available in 30.0 and 31.8mm sizes.



# Stainless Steel Seatpost Clamp

Rated fully KICKASS by the U. S. Department of Wicked Shit, our cast and polished stainless steel clamps won't rust or chip paint because they can't (even the black ones!). They're shiny! They look good! And most importantly, they deliver the clampability seatposts crave. 30.0 and 31.8mm sizes.

**Color:** Silver or Black



# Tuggnut™ Chain Tensioner

Ever stomp on the pedals just to have your rear wheel slide forward in the dropouts and throw your chain? We have...using all kinds of hubs in all kinds of frames. There are lots of BMX-style tensioners out there, but few of them fit in our dropouts without some serious grinding. So, we decided to design a chain tensioner that will keep that rear wheel static in our dropouts...and most other kinds of rear-facing horizontal dropouts. Plus, ours will open up a bottle o' brew. The body of the Tuggnut is investment cast in stainless steel for durability. It features a winged bolt for tool-free adjustments, and two axle holes for a wide range of fore/aft wheel positions. The Tuggnut comes with an aluminum adapter that reduces the axle hole from 10-6mm, so you can use it with quick-release axles, in addition to nutted axles. We sell it as a single, because you really only need one...on the drive side. But if you absolutely need one on the non-drive side of your rig to achieve balance in your life you are in luck...the bottle opener works either way.



## Surly Hip Flask



Hey mang! I'm Flasky! You know, where ever I go people are always saying to me "Flasky, you're a good friend. You keep me warm when I'm cold, loose when I'm tight, and twirling when I should be sleeping." Hey, I try! But I want people to know how tough I am! Not even a dog can hurt me! Well maybe a dog could, I don't know, like if it was maybe a pit-bull or something. Especially an alcoholic pit-bull who hadn't had a drink in a while. But still, I'm pretty tough cuz I'm stainless steel. I don't rust and I don't trap flavors like plastic. That way your gin don't taste like your juice. I'm a good size too; more than enough but never too much, except sometimes. So yeah, that's me. Let's go for a ride. Right now. C'mon, don't be stuck up.

**Stainless steel. 6 oz (177ml)**

## Jethro Tule™

Our Jethro Tule pocket tool combines an offset box wrench on one end with a bottle opener on the other. It's crafted from stainless steel, then polished.

The double-sided 15mm box wrench works with most nutted hubs on the market, and it fits nicely inside recessed dropouts, including those found many of our frames (the 1x1, Steamroller, Karate Monkey and Pugsley). The smooth, spoon-shaped handle provides ergonomic pleasure for your palm under the most rigorous wheel-removing operations, and it opens a cool refreshing bottle of whatchoogot after the ride. It works like it's supposed to and feels good in your pocket.



## Junk Strap

Our Junk Straps are basically really long toe straps. They're 120cm woven nylon with a stainless steel buckle. We had them made to our specifications to ensure that they work well and last a long time. They're easy to use and they stay tight. Once you're ready, loosening them is quick and easy. They're light, pack small, and securely and conveniently attach all kinds of stuff to your rack, basket, handlebar, backpack, under your seat, around your thigh...just about anyplace. Use them to secure small dogs to your child. If your buddy breaks his leg, you can use a few to hold a splint in place while you drag him out of the woods. Wear one as a stylish belt (if your waist is smaller than 120cm). You can combine them for even longer straps. Available singly with a header card and in 6 packs with no header.

# Instigator Dropouts

Our heavy-duty Instigator dropouts are investment cast CroMoly and include 51mm IS disc mounts. They can be TIG-welded or brazed.



# Horizontal Dropouts

Our investment-cast CroMoly horizontal dropouts (also called track ends) come in two versions: with or without derailleur tab. These are the same dropouts that we use on our 1x1, Steamroller and Karate Monkey frames. They can be TIG-welded or fillet brazed.

# Disc Housing Guides

Investment cast CroMoly. TIG-weld or fillet braze them on. Plenty o' room for zip ties.



# Cross-Check Fork Crown

We offer our Cross-Check fork crown to you builders who are looking for a wide, lugged 'cross-worthy' crown that will accommodate a 45mm-wide tire. Our investment cast crown was designed to accommodate a 1-1/8" steerer tube and 28 x 20mm fork blades.

# Patches

**Sizes:**

- 4" wide
- 6.5" wide
- 10" wide

# Frame Decals

Complete decal sets are available for each frame we sell. Decals are dry transfer style. Each decal set includes a headbadge.

# Stickers

**Sizes:**

- 6.4 x 1.75"
- 12 x 2.73"
- 24 x 5.46"



# Cycling Caps

Our caps are made in the US by Walz Caps of 100% wool fabric because wool works well for moisture, temperature and odor control. They come in two sizes to fit a wide range of melons.

**Color:** Black.

**Sizes:** S/M or L/XL



# Logo Socks

As you must know by now, wool resists odor. We have found that is a good feature in a sock. They also wick and insulate better than cotton or all synthetic, so you can wear them comfortably in a pretty wide range of climates. Surly socks are made by DeFeet. We offer four designs in a 5" height and a knee high model. The tall sock is thicker than the others and plays well with knickers (as we call them here in the US. Yes, we know it means ladies' underwear in the UK).

Each design comes in four sizes so pretty much everyone should find one that fits.



Size	Euro	US Men's	US Women's
<b>S</b>	36-39.5	—	6-8
<b>M</b>	40-42.5	7-9	8.5-10.5
<b>L</b>	43-46.5	9.5-11.5	11-13
<b>XL</b>	48+	12+	—

# Wool Jerseys

Our jerseys are made of Merino wool. Merino is soft, naturally odor resistant and insulating, so it works well in warmer weather to keep you cool as well as cool weather to keep you warm. Our jerseys are a medium weight, so best suited for mid-range climates. They make a good base layer in cold weather and are decidedly understated, in sharp and deliberate contrast to most of the hyper-logoized cycle clothes available these days. We recommend you hand wash them in cold water with mild soap.

We almost always have black, plus at least one other color option. Call or write or talk to the good people down at your local bike shop to find out what's available.

- 100% Merino wool
- Available in short or long-sleeve, men's and women's
- 11" zipper
- Zippered rear pocket
- Embroidered logos
- Size: S-XL



# T-Shirts

As any frat boy can tell you, you can't truly be a capitalist pig if you don't sell t-shirts with your logo on them. We poured ourselves a tall glass of that voodoo a long time ago. And to prove what thoughtful corporate citizens we are, we recently decided to go with organic cotton t-shirts. There will be some mixed stock for a while but soon you'll be able to advertise for us and feel good about doing your part for the environment. Won't that be nice?



## Karate Monkey T

Black. Short and long sleeve. Small logo on the left boob. The Karate Monkey his-self on the back. Sizes M-XXL.



## Big Dummy T

WARNING: Wearing this shirt may result in laughter, disgust or loss of employment. Clearly these are for wearing while riding your Big Dummy (see frames and bikes section). Nonetheless, some feel they may not be suitable for all viewers. And those are not the fun people. Current color is blue with gold ink. Sizes S-XL.



## Grrply T

Black. Girl cut, cap-type sleeves. Sizes S-XL.



## Logo Tee

It's not just a name, it's a whole personality type. Shirts are black. Short or long sleeve. Just the logo on the front. Sizes S-XXL.

# Big Dummy Frame Geometry

## Geometry:

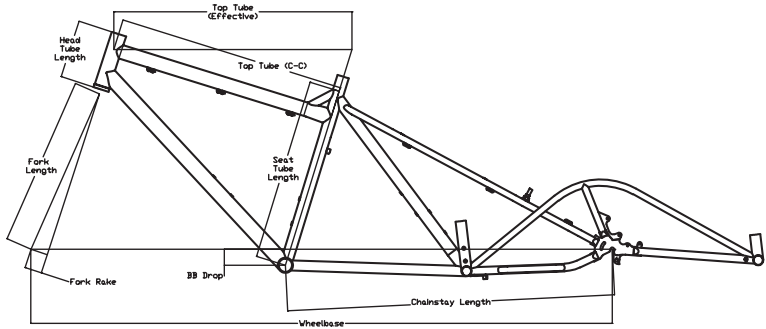

Size	ST (C-T)		TT (C-C)*		TT (Effective)		HT Angle degrees	ST Angle degrees	BB Drop		CS Length	
	inches	mm	inches	mm	inches	mm			inches	mm	inches	mm
<b>small</b>	16.0	406.4	22.7	550.6	22.6	573.5	72.0	73.0	1.6	40.0	32.6	827.0
<b>medium</b>	18.0	457.2	22.4	570.1	23.5	596.1	72.0	73.0	1.6	40.0	32.6	827.0
<b>large</b>	20.0	508.0	23.2	588.7	24.2	614.1	72.0	73.0	1.6	40.0	32.6	827.0
<b>x-large</b>	22.0	558.8	24.0	609.6	24.9	631.8	72.0	73.0	1.6	40.0	32.6	827.0

Size	Wheel Base		S.O. Height**		HT Length		FK Length		FK Rake	
	inches	mm	inches	mm	inches	mm	inches	mm	inches	mm
<b>small</b>	56.5	1435.9	29.1	740.4	5.2	131.7	16.7	425.0	1.7	43.0
<b>medium</b>	57.4	1458.8	30.4	771.5	5.7	145.9	16.7	425.0	1.7	43.0
<b>large</b>	58.1	1477.0	31.6	802.9	6.3	160.8	16.7	425.0	1.7	43.0
<b>x-large</b>	58.9	1495.0	32.9	835.8	7.0	178.8	16.7	425.0	1.7	43.0

\* All dimensions are preliminary and are subject to change

\*\*Measurements use tire with diameter of 676mm (average 26 x 2.1")

# Long Haul Trucker & LHT DeLuxe Geometry

## Geometry:

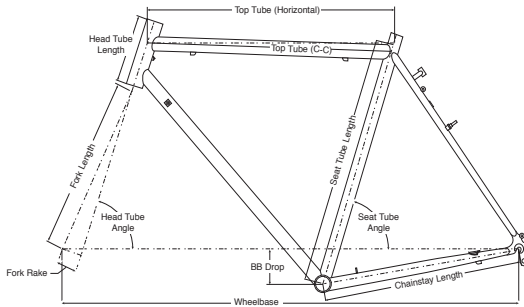

## 26" Wheels

Size	ST (C-T)		TT (C-C)*		TT (Effective)		Toptube Angle degrees	HT Angle degrees	ST Angle degrees	BB Drop		CS Length	
	inches	mm	inches	mm	inches	mm				inches	mm	inches	mm
<b>42cm</b>	16.5	420.0	19.4	492.6	19.9	505.0	7.0	70.0	75.0	1.9	47.0	18.1	460.0
<b>46cm</b>	18.1	460.0	20.0	508.3	20.3	515.0	3.0	70.0	74.5	1.9	47.0	18.1	460.0
<b>50cm</b>	19.7	500.0	20.7	525.0	20.9	530.0	2.0	71.0	74.0	1.9	47.0	18.1	460.0
<b>52cm</b>	20.5	520.0	21.1	534.8	21.3	540.0	2.0	71.0	73.5	1.9	47.0	18.1	460.0
<b>54cm</b>	21.3	540.0	21.6	549.5	21.9	555.0	2.0	71.0	73.0	1.9	47.0	18.1	460.0
<b>56cm</b>	22.0	560.0	22.2	564.1	22.4	570.0	2.0	71.0	73.0	1.9	47.0	18.1	460.0
<b>58cm</b>	22.8	580.0	22.8	579.8	23.1	586.0	2.0	71.0	72.5	1.9	47.0	18.1	460.0
<b>60cm</b>	23.6	600.0	23.4	594.3	23.6	600.0	2.0	71.5	72.5	1.9	47.0	18.1	460.0
<b>62cm</b>	24.4	620.0	23.8	603.4	24.0	610.0	2.0	71.5	72.0	1.9	47.0	18.1	460.0

Size	Wheel Base		S. O. Height**		HT Length		FK Length		FK Rake	
	inches	mm	inches	mm	inches	mm	inches	mm	inches	degrees
<b>42cm</b>	40.8	1036.6	27.7	703.0	4.4	110.7	14.8	376.0	1.8	45.0
<b>46cm</b>	41.1	1042.7	28.5	723.8	4.6	116.7	14.8	376.0	1.8	45.0
<b>50cm</b>	41.2	1046.8	29.8	756.9	5.7	144.0	14.8	376.0	1.8	45.0
<b>52cm</b>	41.5	1053.1	30.5	775.1	6.4	163.0	14.8	376.0	1.8	45.0
<b>54cm</b>	41.9	1064.0	31.2	793.1	7.2	182.0	14.8	376.0	1.8	45.0
<b>56cm</b>	42.5	1079.8	32.0	812.1	8.0	203	14.8	376.0	1.8	45.0
<b>58cm</b>	43.0	1091.2	32.7	829.9	8.7	222	14.8	376.0	1.8	45.0
<b>60cm</b>	43.3	1100.4	33.4	848.1	9.4	238	14.8	376.0	1.8	45.0
<b>62cm</b>	43.5	1105.1	34.1	866.8	10.2	259	14.8	376.0	1.8	45.0

## 700c Wheels

Size	ST (C-T)		TT (C-C)*		TT (Effective)		Toptube angle degrees	HT Angle degrees	ST Angle degrees	BB Drop		CS Length	
	inches	mm	inches	mm	inches	mm				inches	mm	inches	mm
<b>56cm</b>	22.0	560.0	22.2	564.4	22.4	570.0	2.0	72.0	73.0	3.1	78.0	18.1	460.0
<b>58cm</b>	22.8	580.0	22.8	580.1	23.1	586.0	2.0	72.0	72.5	3.1	78.0	18.1	460.0
<b>60cm</b>	23.6	600.0	23.4	593.8	23.6	600.0	2.0	72.0	72.5	3.1	78.0	18.1	460.0
<b>62cm</b>	24.0	620.0	23.8	603.5	24.0	610.0	2.0	72.0	72.0	3.1	78.0	18.1	460.0

Size	Wheel Base		S. O. Height**		HT Length		FK Length		FK Rake	
	inches	mm	inches	mm	inches	mm	inches	mm	inches	mm
<b>56cm</b>	41.6	1055.7	32.0	812.2	6.0	152.0	15.4	390.0	1.8	45.0
<b>58cm</b>	42.0	1066.7	32.7	830.0	6.7	171.0	15.4	390.0	1.8	45.0
<b>60cm</b>	42.6	1080.9	33.5	849.7	7.4	189.0	15.4	390.0	1.8	45.0
<b>62cm</b>	42.7	1085.3	34.1	867.3	8.3	210.0	15.4	390.0	1.8	45.0

\*\*All dimensions are subject to change

\*\*Measurements for 26" frame are calculated using a tire with a diameter of 628mm, and for 700c frames using a tire diameter of 690mm.



# Karate Monkey Geometry

## Geometry:

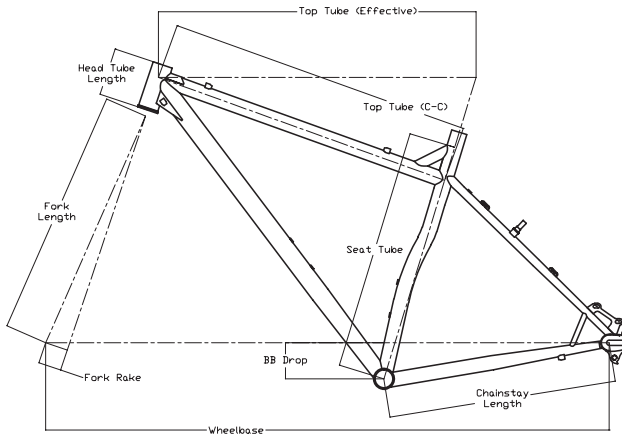

Size	ST (C-T)		TT (C-C)*		TT (Effective)		HT Angle degrees	ST Angle degrees	BB Drop		CS Length	
	inches	mm	inches	mm	inches	mm			inches	mm	inches	mm
<b>small</b>	16.0	406.4	22.0	558.1	22.7	576.4	71.0	73.0	2.7	68.0	17.0	431.0
<b>medium</b>	18.0	457.2	22.6	574.4	23.6	600.0	71.5	73.0	2.7	68.0	17.0	431.0
<b>large</b>	20.0	508.0	23.2	590.4	24.3	616.8	72.0	73.0	2.7	68.0	17.0	431.0
<b>x-large</b>	22.0	558.8	24.0	632.7	24.0	632.7	72.0	73.0	2.7	68.0	17.0	431.0

Size	Wheel Base		Front-Center		S.O. Height**		HT Length		FK Length		FK Rake	
	inches	mm	inches	mm	inches	mm	inches	mm	inches	mm	inches	mm
<b>small</b>	41.2	1046.1	24.5	623.0	30.0	760.8	3.5	90.0	18.4	468.0	1.7	43.0
<b>medium</b>	42.0	1064.6	25.3	642.0	31.0	786.1	3.5	90.0	18.4	468.0	1.7	43.0
<b>large</b>	42.4	1076.5	25.7	654.0	32.0	813.6	3.7	95.0	18.4	468.0	1.7	43.0
<b>x-large</b>	43.0	1092.6	26.4	670.0	33.2	842.6	4.1	105.0	18.4	468.0	1.7	43.0

\*\*Standover height is based on a 29 x 2.1" tire that measured 737mm in diameter

# Pacer Frame Geometry

## Geometry:

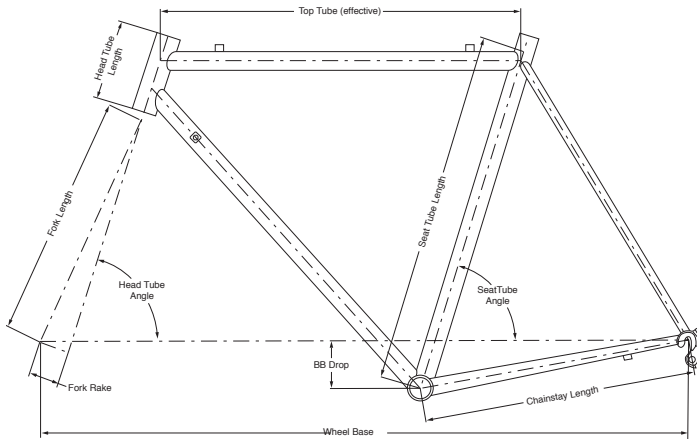

Size	ST (C-T)		TT (C-C)		TT (Effect.)		HT Angle degrees	ST Angle degrees	BB Drop		CS Length	
	inches	mm	inches	mm	inches	mm			inches	mm	inches	mm
<b>42cm</b>	16.5	420.0	19.4	491.5	19.9	506.0	71.5	75.5	2.8	72.0	16.1	410.0
<b>46cm</b>	18.1	460.0	19.9	504.2	20.3	515.0	71.5	75.0	2.8	72.0	16.1	410.0
<b>50cm</b>	19.7	500.0	20.7	526.4	20.9	530.0	72.0	74.5	2.8	72.0	16.1	410.0
<b>52cm</b>	20.5	520.0	21.3	540.0	21.3	540.0	72.5	74.0	2.8	72.0	16.1	410.0
<b>54cm</b>	21.3	540.0	21.7	550.0	21.7	550.0	72.5	73.5	2.8	72.0	16.3	415.0
<b>56cm</b>	22.0	560.0	22.2	565.0	22.2	565.0	73.0	73.0	2.8	72.0	16.3	415.0
<b>58cm</b>	22.8	580.0	22.8	580.0	22.8	580.0	73.5	73.0	2.8	72.0	16.3	415.0
<b>60cm</b>	23.6	600.0	23.2	590.0	23.2	590.0	73.5	72.5	2.8	72.0	16.3	415.0
<b>62cm</b>	24.4	620.0	23.8	605.0	23.8	605.0	74.0	72.5	2.8	72.0	16.3	415.0

Size	Wheel Base		S.O. Height**		HT Length		FK Length		FK Rake	
	inches	mm	inches	mm	inches	mm	inches	mm	inches	mm
<b>42cm</b>	38.4	974.4	28.2	715.3	3.5	89.0	14.6	371.0	2.0	50.0
<b>46cm</b>	38.5	978.8	28.9	735.2	4.1	104.0	14.6	371.0	2.0	50.0
<b>50cm</b>	38.8	985.6	29.8	756.1	4.1	104.0	14.6	371.0	2.0	50.0
<b>52cm</b>	38.9	987.2	30.2	767.9	4.3	109.0	14.6	371.0	2.0	50.0
<b>54cm</b>	39.1	992.8	30.9	785.7	4.9	124.0	14.6	371.0	1.8	45.0
<b>56cm</b>	39.3	998.7	31.6	803.5	5.6	141.0	14.6	371.0	1.8	45.0
<b>58cm</b>	39.7	1008.6	32.4	822.7	6.3	159.0	14.6	371.0	1.8	45.0
<b>60cm</b>	39.9	1013.7	33.1	840.2	6.9	176.0	14.6	371.0	1.8	45.0
<b>62cm</b>	40.3	1023.4	33.8	859.3	7.6	194.0	14.6	371.0	1.8	45.0

\*\*Standover height is based on a 700c x 25mm Michelin Axial Pro tire that measured 680mm in diameter

# Cross-Check Frame Geometry

## Geometry:

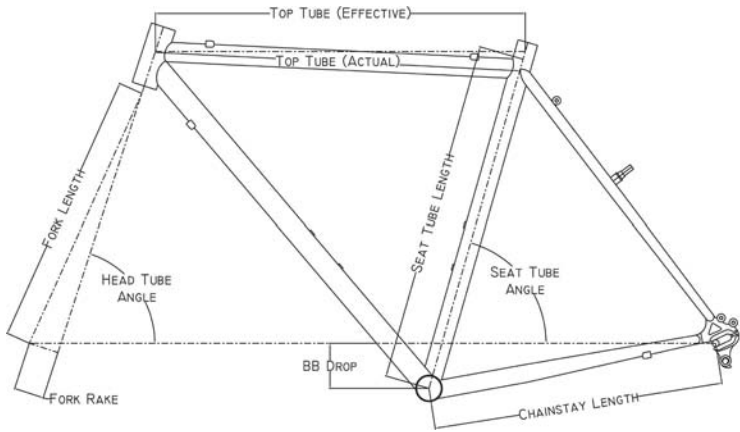

Size	ST (C-T)		TT (C-C)		TT (Effect.)		HT Angle degrees	ST Angle degrees	BB Drop		CS Length	
	inches	mm	inches	mm	inches	mm			inches	mm	inches	mm
<b>42cm</b>	16.5	420.0	19.9	505.0	20.6	522.0	72.0	75.0	2.6	66.0	16.5	420.0
<b>46cm</b>	18.1	460.0	20.3	515.0	20.8	528.8	72.0	74.5	2.6	66.0	16.5	420.0
<b>50cm</b>	19.7	500.0	21.1	535.0	21.3	541.8	72.0	74.0	2.6	66.0	16.7	425.0
<b>52cm</b>	20.5	520.0	21.5	545.0	21.5	547.1	72.0	73.5	2.6	66.0	16.7	425.0
<b>54cm</b>	21.3	540.0	22.0	560.0	22.0	560.0	72.0	73.0	2.6	66.0	16.7	425.0
<b>56cm</b>	22.0	560.0	22.4	570.0	22.4	570.0	72.0	72.5	2.6	66.0	16.7	425.0
<b>58cm</b>	22.8	580.0	22.8	580.0	22.8	580.0	72.0	72.5	2.6	66.0	16.7	425.0
<b>60cm</b>	23.6	600.0	23.6	600.0	23.6	600.0	72.0	72.0	2.6	66.0	16.7	425.0
<b>62cm</b>	24.4	620.0	24.0	610.0	24.0	610.0	72.0	72.0	2.6	66.0	16.7	425.0

Size	Wheel Base		S.O. Height*		HT Length		FK Length		FK Rake	
	inches	mm	inches	mm	inches	mm	inches	mm	inches	mm
<b>42cm</b>	39.0	989.9	28.8	731.9	3.6	91.0	15.7	400.0	1.7	44.0
<b>46cm</b>	39.1	991.9	29.6	750.7	3.6	91.0	15.7	400.0	1.7	44.0
<b>50cm</b>	39.6	1005.3	30.3	769.4	3.6	91.0	15.7	400.0	1.7	44.0
<b>52cm</b>	39.6	1006.0	30.6	778.4	3.6	91.0	15.7	400.0	1.7	44.0
<b>54cm</b>	39.9	1014.4	31.2	793.0	4.0	102.0	15.7	400.0	1.7	44.0
<b>56cm</b>	40.1	1019.8	31.9	810.7	4.8	121.0	15.7	400.0	1.7	44.0
<b>58cm</b>	40.6	1030.0	32.7	829.9	5.6	141.0	15.7	400.0	1.7	44.0
<b>60cm</b>	41.1	1044.8	33.4	847.4	6.3	160.0	15.7	400.0	1.7	44.0
<b>62cm</b>	41.5	1054.7	34.1	866.2	7.1	180.0	15.7	400.0	1.7	44.0

\*Measurements use tire with 685mm outer diameter (Ritchey 700c x 30mm SpeedMax), and taken from middle of toptube to level ground

# Steamroller Frame Geometry

## Geometry:

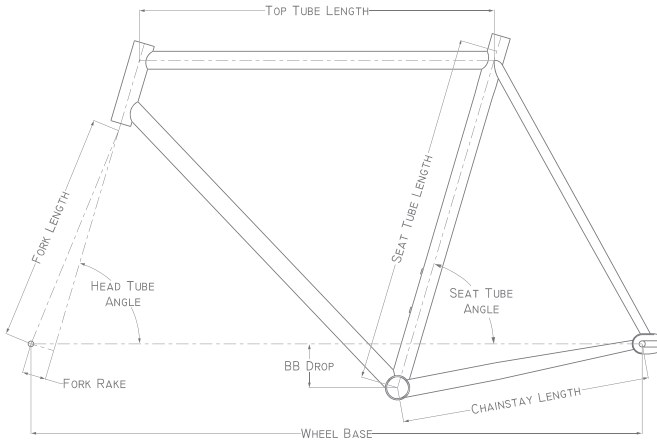

Size	ST (C-T)		TT (C-C)		TT (Effect.)		HT Angle degrees	ST Angle degrees	BB Drop		CS Length	
	inches	mm	inches	mm	inches	mm			inches	mm	inches	mm
<b>49cm</b>	19.3	490.0	20.7	526.5	20.8	529.5	72.5	74.5	2.8	70.0	15.7	398.0
<b>53cm</b>	20.9	530.0	21.5	547.0	21.5	547.0	73.0	74.0	2.8	70.0	15.7	398.0
<b>56cm</b>	22.0	560.0	22.4	568.0	22.4	568.0	73.5	73.5	2.8	70.0	15.7	398.0
<b>59cm</b>	23.2	590.0	23.1	587.0	23.1	587.0	74.0	73.0	2.8	70.0	15.7	398.0
<b>62cm</b>	24.4	620.0	23.9	608.0	23.9	608.0	74.0	73.0	2.8	70.0	15.7	398.0

Size	Wheel Base		S.O. Height*		HT Length		FK Length		FK Rake	
	inches	mm	inches	mm	inches	mm	inches	mm	inches	mm
<b>49cm</b>	38.0	965.7	29.5	748.5	3.3	83.0	14.8	375.0	1.5	38.0
<b>53cm</b>	38.1	966.6	30.7	780.5	4.3	109.0	14.8	375.0	1.5	38.0
<b>56cm</b>	38.5	978.6	31.8	807.9	5.4	136.0	14.8	375.0	1.5	38.0
<b>59cm</b>	38.9	987.6	32.9	835.2	6.4	163.0	14.8	375.0	1.5	38.0
<b>62cm</b>	39.7	1009.1	34.1	865.3	7.7	196.0	14.8	375.0	1.5	38.0

\*Measurements use tire with outer diameter of 682mm (700c x 28mm), and taken from middle of toptube to level ground

# Pugsley Frame Geometry

## Geometry:

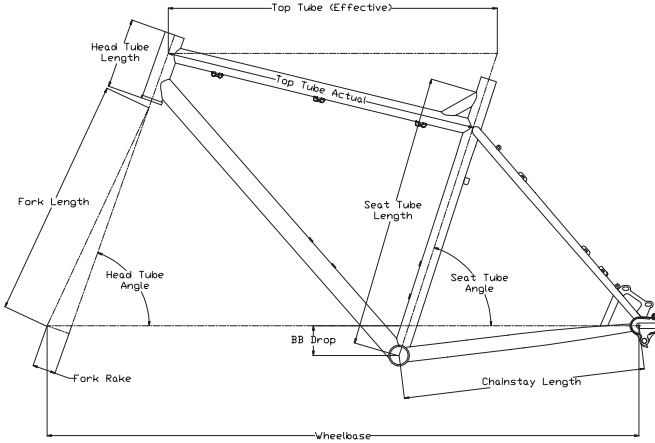

Size	ST (C-T)		TT (C-C)		TT (Effect.)		HT Angle degrees	ST Angle degrees	BB Drop		CS Length	
	inches	mm	inches	mm	inches	mm			inches	mm	inches	mm
<b>16"</b>	16.0	406.4	21.8	554.3	22.9	580.9	70.5	72.0	2.2	55.0	17.6	448.1
<b>18"</b>	18.0	457.2	22.3	566.5	23.5	595.6	70.5	72.0	2.2	55.0	17.6	448.1
<b>20"</b>	20.0	508.0	23.0	581.9	24.0	610.1	70.5	72.0	2.2	55.0	17.6	448.1
<b>22"</b>	22.0	558.8	23.6	600.0	24.6	625.0	70.5	72.0	2.2	55.0	17.6	448.1

Size	Wheel Base		S.O. Height**		HT Length		FK Length		FK Rake	
	inches	mm	inches	mm	inches	mm	inches	mm	inches	mm
<b>16"</b>	42.0	1067.4	29.3	745.1	4.0	102.0	17.6	447.0	1.7	43.0
<b>18"</b>	42.6	1082.4	30.5	773.5	4.4	112.0	17.6	447.0	1.7	43.0
<b>20"</b>	43.2	1097.3	31.7	805.4	5.1	130.0	17.6	447.0	1.7	43.0
<b>22"</b>	43.8	1112.7	33.1	839.7	5.9	150.0	17.6	447.0	1.7	43.0

\*\*Standover height measured using Surly Endomorph 3.7" tire measuring 740mm in diameter

# Troll Frame Geometry

## Geometry:

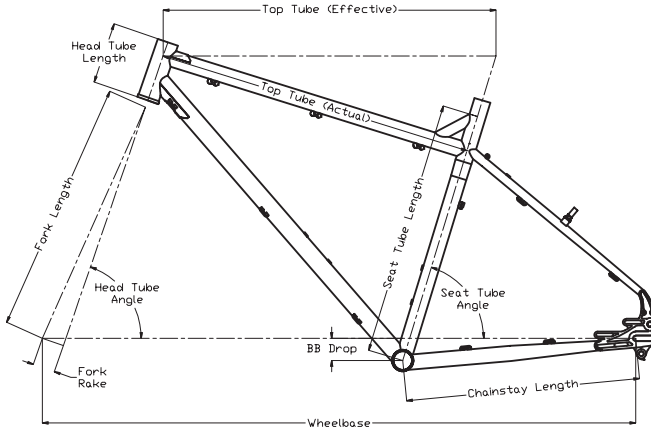

Size	ST (C-T)		TT (C-C)*		TT (Effective)		HT Angle degrees	ST Angle degrees	BB Drop		CS Length	
	inches	mm	inches	mm	inches	mm			inches	mm	inches	mm
14	14	356	20.9	532	21.5	546	71	73	1.6	40	16.5	419
16"	16	406	21.6	549	22.5	571	71	73	1.6	40	16.5	419
18"	18	457	22.4	570	23.5	596	71	73	1.6	40	16.5	419
20"	20	508	23.2	590	24.3	616	71	73	1.6	40	16.5	419
22"	22	559	23.9	608	24.8	631	71	73	1.6	40	16.5	419

Size	Wheel Base		S.O. Height**		HT Length		FK Length		FK Rake	
	inches	mm	inches	mm	inches	mm	inches	mm	inches	mm
14"	39.8	1012	28.3	718	3.5	90	17.8	453	1.6	40
16"	40.8	1037	29.4	746	3.9	100	17.8	453	1.6	40
18"	41.9	1063	30.5	774	4.3	110	17.8	453	1.6	40
20"	42.6	1083	31.7	804	4.9	125	17.8	453	1.6	40
22"	43.3	1099	33	837	5.7	145	17.8	453	1.6	40

\* All dimensions are preliminary and are subject to change

\*\*Measurements use tire with a diameter of 676mm (Toga 2.1" DH), taken from middle of the toptube to level ground

# 1x1 Frame Geometry

## Geometry:

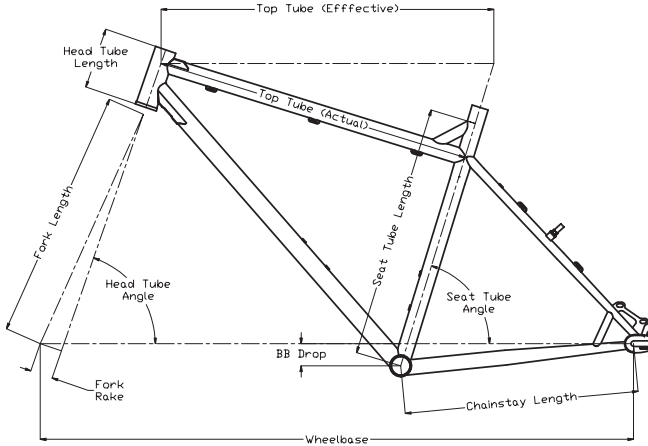

Size	ST (C-T)		TT (C-C)		TT (Effect.)		HT Angle		ST Angle		BB Drop		CS Length	
	inches	mm	inches	mm	inches	mm	degrees	degrees	inches	mm	inches	mm		
<b>x-small</b>	14.0	355.6	20.9	532.0	21.5	546.0	71.0	73.0	1.6	40.0	16.5	419.0		
<b>small</b>	16.0	406.4	21.6	549.0	22.5	571.0	71.0	73.0	1.6	40.0	16.5	419.0		
<b>medium</b>	18.0	457.2	22.4	570.0	23.5	596.0	71.0	73.0	1.6	40.0	16.5	419.0		
<b>large</b>	20.0	508.0	23.2	590.0	24.3	616.0	71.0	73.0	1.6	40.0	16.5	419.0		
<b>x-large</b>	22.0	558.8	23.9	608.3	24.8	631.0	71.0	73.0	1.6	40.0	16.5	419.0		

Size	Wheel Base		S.O. Height*		HT Length		FK Length		FK Rake	
	inches	mm	inches	mm	inches	mm	inches	mm	inches	mm
<b>x-small</b>	39.8	1012.0	28.3	718.0	3.5	90.0	17.8	453.0	1.6	40.0
<b>small</b>	40.8	1037.0	29.4	746.0	3.9	100.0	17.8	453.0	1.6	40.0
<b>medium</b>	41.9	1063.0	30.5	774.0	4.3	110.0	17.8	453.0	1.6	40.0
<b>large</b>	42.6	1083.0	31.7	804.0	4.9	125.0	17.8	453.0	1.6	40.0
<b>x-large</b>	43.3	1099.0	33.0	837.0	5.7	145.0	17.8	453.0	1.6	40.0

\*Measurements use tire with diameter of 676mm (Tloga 2.1" DH), and taken from middle of toptube to level ground



**6400 W. 105th St.**

**Bloomington, MN 55438**

Phone: 877.743.3191

Web: [www.surlybikes.com](http://www.surlybikes.com)

E-mail: [derby@surlybikes.com](mailto:derby@surlybikes.com)



**Printed on 100% recycled paper using soy ink**

**Volume 1**