



**SURLY**

Bikes. Parts. Chaos.  
2013 Catalog

**TABLE OF CONTENTS**

**BIKES AND FRAMES**  
P. 2-15

**TIRES**  
P. 19-20

**FORKS**  
P. 29-33

**RIMS**  
P. 21-23

**TRAILERS**  
P. 16-18

**BAR, RACKS  
& OTHER STUFF**  
P. 34-38

**WEARABLE STUFF**  
P. 39-41

**DRIVETRAIN**  
P. 24-28

**GEOMETRIES  
COMPONENT SPECS  
FRAME INFO**  
P. 42-66



**AND NOW A WORD FROM THE BIG GIANT HEAD**

In the last 100 years technology has striven to improve upon the functionality of steel as a building material (as they have the vinyl record for entertainment and wool for clothing). One school of thought has been obsessed with creating new materials that solve problems in a different ways (aluminum, titanium, carbon fiber). From our point of view this adds endless layers of complexity and often creates new problems along the way. Another school has spent its time refining and improving the original material, arriving at what is modern steel...it is for the most part the same stuff your grand daddy rode, just stronger, lighter, and more refined to specific purposes.

Surly is of this second school; we like to use technology to improve the wheel, not reinvent it. We like the refinement process. We don't use new technologies for the sake of using new technologies, but rather look at what we want to achieve and apply what works, whether its new or not. That's why we make our bikes out of steel. It's not because we are old fashioned, or curmudgeonly (though many of us are in fact curmudgeons). We're not retrogrouch crusaders. We use steel because it works consistently and inexpensively. It's not that other materials aren't cool. We are interested and intrigued by the properties of all the things that make up our world. But for the kind of bikes we make, for the rides we like and the things we value, steel can't be beat.

This year we're launching a new model, the Krampus. It's got 3" tires on 50mm rims. In working on this project it became very apparent that the classic frame size naming method we have used for our mountain (or as we call it: omni-terra) bikes would not work. So we've updated how we describe the sizes of our bikes. Don't worry, the geometry-based sizing you've come to know (love/hate) hasn't changed. We're just calling it by a slightly different name. And since other bike companies tend to use this sort of naming, maybe it isn't so new to you. Where we used to say 18" we're now calling it a medium.

The biggest reason for this is it allows us more flexibility in how we design our bikes while conveying that two bikes are intended to fit the same. A couple years ago we decided to drop our toptubes, as we felt some of our bikes could use a bit more stand over clearance for those important bits between your legs. When we did this we added a little brace in at the seattube. This ended up confusing people trying to figure out their correct size. While working on Krampus we really wanted to keep our stand over measurements as close as we could to our existing bikes. But bigger tires mean you need to build in lower stand over clearances. This created all types of inconsistencies if we had kept the old naming paradigm.

Let's walk through an example. Take the new medium. If we hadn't changed our naming convention, the Krampus would be a 16.7", or 17" rounded up to a whole number. This would have the same stand over height as a similar 18" Moonlander or Karate Monkey.

The issue comes from what your expectations are. We want our bikes to fit similarly between models. The 17" Krampus has a similar effective toptube length (and stand over!) of the 18" KM. So a 17" Krampus and 18" Karate Monkey are now 'mediums.' You can still look at our geometry charts and get the exact numbers if you're into that sort of thing. But the quick glance will now reveal a simpler approach, one we think will be clearer for a lot of people.

Hugs,

The Surly Central Scrutinizer

# KRAMPUS

available as frame or complete bike

There's been a lot of buzz lately about fat bikes such as our Pugsley and Moonlander, bikes with massive 4 and 5" tires designed to crawl over and through unusual or difficult terrain. These types of bikes are all about stability, traction, and floatation.

The Krampus is not the same animal. True, it's got bigger-than-usual tires (29 x 3" Knard tires on 50mm Rabbit Hole rims, to be exact), a platform we have dubbed "29+". But as you may know, we're not the kind of people to just throw on bigger-than-usual tires for no reason, or to attract attention. While the big tires are impossible to ignore, and do in fact offer increased traction and some degree of float, don't assume that these big tires are only for slow speed crawling. The Krampus's frame (geometry, tubing diameter and thickness) has been designed with a long toptube and as short a rear end as we could get away with. This, when combined with the big, wide tires, results in a mad amount of rolling inertia and grip. It can go real fast. It responds well to body English.

So Krampus rolls fast, holds speed, corners like it's on rails, etc. At this point you may be thinking, "Wha? Surly make race bike?" Well no, not exactly. It's still a Surly...durable, slightly overbuilt. It does exceedingly well rolling over all kinds of stuff, things you'd normally think you'd need suspension to tangle with. Krampus lives somewhere between bushwhacking, speed racing, and back lot dirt track riding, and all this makes it just plain fun to ride.

Hub spacing is standard 100mm front and 135mm rear, with rear fork ends that accommodate a derailleur or singlespeed set up. Krampus features our Trip Guides for running full length derailleur housing and brake line. Note that there is no housing stop for a front derailleur, as it was designed to run a high direct mount standard front derailleur. This type of derailleur will allow the most clearance at the tire. Even though there is no need for frame offset as on frames meant for 4 and 5" tires, chain and derailleur clearance at the tire remains a serious consideration. It breaks down like this:

If you plan to use standard width rims and tires, you'll be able to run a normal mountain triple crank. However, if you go with our 50mm rims and 3" tires (and why wouldn't you?) then plan to use a 1x or 2x crank...a triple simply won't clear the tire. For best chain/tire clearance, we recommend either a Surly MWOD 2x crank or a 1x system. Other brands' 2x cranks will work but may cause some chain-on-tire rub in the easiest gear combo. Got all that?

Someday, when the bicycles and insects have merged their lineages and become the dominant, unstoppable race on the planet Earth, Krampus will no doubt be this new species' Sarah Connor. We're looking forward to it.



**New**

See page 42 for complete Krampus frame specs and geometry grid.

See page 43 for complete Krampus bike specs.



Color: Moonlit Swamp

# KARATE MONKEY

available as frame or complete bike

29" wheels, as you may know, deliver greater traction than 26" wheels; they smooth out terrain more effectively, hold inertia well, and in general they fit taller riders better than 26" wheeled bikes. When it was introduced, the Karate Monkey was one of the first (the first?) production 29'ers. Not only did the Monkey put the 29" platform in front of a lot of people, it did so at a price within reach of many a bike nerd. Back then there were only about three tire options! Since then 29-inch has become a full-blown category, with entire bike companies dedicated to the platform.

Even now, however, the Karate Monkey continues to amaze people even though it's nearly the same as when it was introduced: our own custom 4130 CroMoly steel tubing make the frame and fork, butted where it matters to provide a durable yet resilient ride. The seattube is curved forward, allowing the rear wheel to tuck under, shortening the wheelbase and increasing rear wheel traction. The crank height provides plenty of ground clearance. The rear "dropouts" are horizontal rear-load style, but with a derailleur hanger. Hmmm, tricky. We offer the complete bike version of the Karate Monkey as a singlespeed but you could turn it into a geared bike if you wanted. Or monster cross it. Fixed-gear off-road it. The Karate Monkey sticks to trail like peanut butter to a dog's mouth. It rides great. That's not just us talking, that's what we hear from customers. You'll see.

We have made some changes though. With the introduction of our Ogre and now our Krampus the Karate Monkey is no longer the only 29-inch wheeled model in our stable, so we took the opportunity to refine it a bit. First, we took off the cantilever studs. The Karate Monkey is disc brake only. The fork, still suspension corrected for 80mm travel, has been redesigned to be more resilient and forgiving.

The Karate Monkey retains threaded barrel mounts on its stays. You can run a rear rack, but if what you really want is an expedition-type 29'er we advise the Ogre. Ogre shares the KM geometry but is designed to run fenders, discs and racks at the same time. If you want a lighter and faster 29'er that can do other stuff from time to time, the Karate Monkey is the way to go. There's a reason the Karate Monkey is still around: Because it rips.



## FRAME DETAILS



See page 44 for complete Karate Monkey frame specs and geometry grid.

See page 45 for complete Karate Monkey bike specs.



Color: Stretchpants Black or Safety Scissors Blue

**OGRE**

available as frame or complete bike

This is OGRE, Troll's big wheeled brother sister. Troll and OGRE offer the same ability to accommodate a wide array of drivetrains, brakes, and cargo-hauling accessories. The main difference is that OGRE runs on 29" wheels, the Troll on 26".

Built of 4130 CroMoly steel and based on the tried-and-true geometry of our venerable Karate Monkey, OGRE is designed to be a platform for exploration, commuting, trailer-pulling, on-road and off-road touring, and just riding along. Both frames feature gusseted sloping toptubes, Surly Trip Guides for running full shift and brake housing, mounts for linear-pull and disc brakes, three bottle cage mounts (the mounts on the top of the downtube allow higher or lower cage placement depending on your needs), and ample room between the stays for high-volume rubber...up to about 2.5".

OGRE comes with our suspension-corrected (80mm) fork. It features mid-blade eyelets and low-blade barrel bosses for mounting front racks. We provide canti pivots and disc brake mounts, so you can choose a system that best suits your stopping needs. And it's specifically designed to allow the use of a fender, disc brake, and front rack at the same time. Yep, you read that right. Oh yeah, we've added bottle cage mounts, one on each side. Each cage can be run in a high or low position, depending on what your equipment and preferences demand, or demanding demander. Carry extra water, stove fuel, jars of peanut butter, boxes of Kleenex, or petrolatum. Just know that bottle cages and a rack won't play well together. Pick one or the other and be happy you have the option.

Like the fork, the rear end allows all-at-once rack, fender and disc compatibility. Spaced for 135mm hubs, the 'dropouts' are just like Troll's...rear load horizontals with a derailleur hanger, slotted disc brake mounts, M10 x 1mm threaded holes for mounting Surly Bill & Ted trailer-connecting hardware (or B.O.B. Nutz), and a dedicated anchoring point for a Rohloff OEM2 axle plate. We designed a ton of versatility into these framesets because we want you to build up a Troll or OGRE the way it will best serve you. Framesets and complete bikes are available in sizes 16, 18, 20, 22 and supergiant 24". Tall folks, we got your back.

The complete bike parts spec is durable and sensible...just the sort of value you expect from a Surly. If you're like us, your bike needs will likely change by the day, week, month or year. Ride it to the office during the day, rip some local single-track after work, use it to tote crates of freakishly-large tubers next weekend, and tour that stretch of off-the-beaten-path double-track next month. With OGRE (and Troll), you can do that.



**FRAME DETAILS**

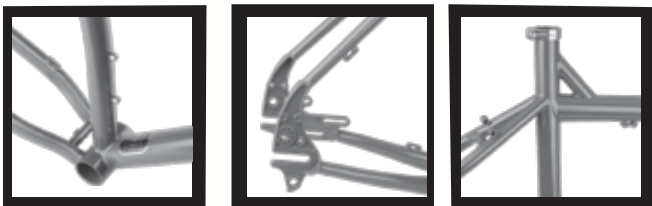

See page 46 for OGRE frame specs and geometry grid.

See page 47 for complete OGRE bike specs.



Color: Army Green or Blactacular

**TROLL**

available as frame or complete bike

Though the Troll's geometry is that of a 26"-wheeled mountain bike, it's unlike most mountain bikes you'll find on your local bike shop floor. It has ample clearance for 28/38/50t mountain-triple chainrings and room for 26 x 2.7" tires. The gusseted front triangle, with its sloping toptube, provides generous standover clearance even when running high-volume rubber.

Build it with a 100mm suspension-corrected fork, or roll the 4130 CroMoly Troll fork. The stock fork is spec'd with canti pivots, disc mounts, low- and mid-blade rack bosses and fender eyelets. Run a rack, fender and disc at the same time, no jury-rigging required.

The Troll frame features horizontal rear-loading dropouts with a derailleur hanger, disc caliper mounting slots, and rack and fender bosses. There's a dedicated area for anchoring a Rohloff hub OEM2 axle plate, and we've included threaded M10 x 1mm holes for installing Surly trailer-mounting nuts or B.O.B. Nutz. The dropout design allows the simultaneous use of a rack, fender and disc brake. We include canti pivots, too. Options, options, options. Marcia, Marcia, Marcia.

Use the Troll as a mountain bike, cruiser, commuter or touring rig. Make it your go-to utility tractor. Try out different tires and handlebars. Add some racks, build it with gears, or strip it down to a singlespeed drivetrain. Take it camping, ride it to the grocery store or session on your favorite single-track. Build it up, ride it for a while, then reinvent it.

Like many of our models, the Troll is available as a frameset or as a complete bike.



**FRAME DETAILS**

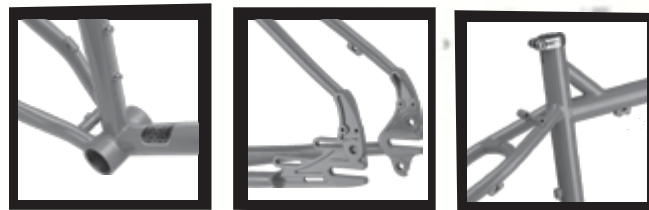

See page 48 for frame specs and geometry grid.

See page 49 for complete Troll bike specs.



Color: Not So Dark Black or Egg Plant

**1X1** Frameset only

Here you find the venerable 1X1, the frame whose name is synonymous with singlespeeds the same way people call facial tissue Kleenex. The 1X1 was designed for 26" wheels, big tires, and single gear and cog drivetrains, like freewheeled singlespeeds, fixed-gear, and even internal geared hubs. No derailleur hanger, no housing stops or line guides for derailleurs. The 1X1 is simple, durable and beautiful.

It's made of Surly 4130 CroMoly, with a custom double-butted main triangle and triple-butted fork blades for a tough yet responsive, lively ride. Adding to that ride feel is its geometry which is, well, simple. It rides like a mountain bike. The chainstays are heat treated to add to its durability. It still has rim brake pivots. They're removable in case you want to clean up the look when you run disc brakes.

Very few design features have been updated over the years. We lowered the toptube a bit to increase stand-over clearance and also made it compatible with 100mm suspension forks. As well, the rear disc caliper mounting plate has been redesigned to allow easier rear wheel removal and installation...no more loosening the adapter bolts to allow the rotor to clear the caliper.

The 1X1 rides like a bike, without a lot of fussin' and fightin'. This is a frame you keep, a frame you use for years and years. It has been around since the very early daze of Surly, and it remains one of our favorites.



**FRAME DETAILS**

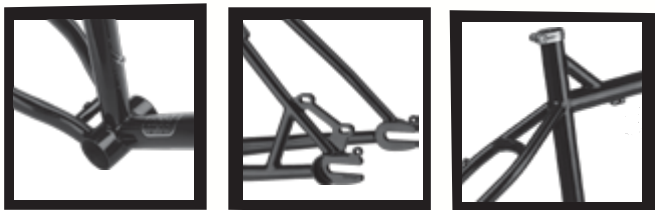

See page 66 for complete 1X1 frame specs and geometry grid.



Color: Cash Black

**MOONLANDER**

available as frame or complete bike

You know by now that Moonlander picks up where Pugsley left off. Moonlander accomodates staggeringly wide 4.7" tires on 100mm rims. Such a large footprint allows you to ride them at very low pressure, and like a snowshoe enables even greater traction and float over all kinds of terrain...wet stuff, roots, rocks, pebbles, gravel, sand, and many types of snow.

Like all of our framesets, the Moonlander is made of Surly 4130 CroMoly steel. It features 135mm-spaced, 28mm-offset, rear-loading Surly horizontal dropouts (track ends) with a derailleur hanger...meaning you can set it up as a singlespeed or geared bike, derailleurs or internally geared. The bottom bracket height gives you clearance for bushwhacking and monster-trucking. The dropped and gusseted toptube maximizes standover height. And the tallish headtube allows you to set your rig up with a comfortable riding position for those long days grinding out miles in the saddle.

Moonlander's fork measures 447mm axle-to-crown...same as the Pug, so all of our fat forks are interchangeable between the two models. The disc mount allows you to use a front disc brake caliper with a 135mm O.L.D. rear hub...or with a 135mm-spaced Surly front hub. Mid-blade thru-eyelets and lower rack barrels are included for installing fenders and racks. We offer the Moonlander as a frameset and as a complete bike. The complete bike components were chosen for their durability and their suitability to the task at hand. We chose Microshift thumbshifters because they allow you to shift even when wearing mittens. To accommodate the Clown Shoe rim/Big Fat Larry tire spec, the frame design pushes the chainline even farther outboard than that of the Pugsley, so we spec'd Moonlander with our new MWOD crank system. The MWOD (Mr. Whirly Offset Double) ditches the big ring and moves the middle and granny ring outboard. The 2 x 9 drivetrain offers the gear ratios most applicable to a bike of this type while avoiding chain/tire interference. Works like a charm.

This year, we changed a few things. The 120tpi Big Fat Larry tires now have a lighter casing, allowing greater conformation to the ground it's rolling over and reducing rolling weight. The fork is offset like the frame to allow front and rear wheel interchangeability. And we're now offering an extra large 24" size, available as a complete bike and also frameset.

Moonlander, like its name implies, is meant to go beyond where normal bikes, even normal fat bikes, can go. It is designed from the ground up to ride where there are no roads, no trails, no people.



**FRAME DETAILS**



See page 50 for Moonlander frame specs and geometry grid.

See page 51 for complete Moonlander bike specs.



Color: Space

**PUGSLEY** available as frame or complete bike

By now you know that Pugsley was created to go where standard "all terrain" bikes flounder. The floatation and traction afforded by large-volume, low-pressure tires can get you over and through otherwise unrideable terrain...sand, mud, wet rocks and roots, ice and many kinds of snow.

The Pugsley frame has 135mm-spaced horizontal rear-loading dropouts with a derailleur hanger. This means you can set it up with a derailleurs drivetrain or an internally-geared hub. Run it with a singlespeed freewheel or a fixed cog. You have lots of drivetrain choices.

The stock fork accepts a 135mm rear mountain hub, just like the frame. This makes it easier to install and remove the wheel (a big tire on a big rim benefits from a wide opening), and it allows front and rear wheel interchangeability. This means you can have the ability to carry another full gear cluster, a singlespeed freewheel, or a fixed cog on the front wheel. And should something go wrong with your primary drivetrain, you have the option of swapping wheels and continuing on your journey or retreating to a place where you can make necessary repairs.

Pugsley is available as a frameset and as a complete bike. The complete bike sports a nice mix of components chosen for their durability and value. This year we changed the complete bike features Marge Lite rims and Microshift thumbshifters, which work well especially when wearing mittens. The front hub is now our Ultra New model, and the front derailleur is now a more modern and sensible D-type, and we include the adapter clamp even if you just buy the frame. We added an extra small (14") frame size too this year, and changed the color to keep things interesting.

There are other fat bikes out there these days. Lots of them use equipment we originally developed for the Pugsley. The Pugsley has not suffered in popularity with these new offerings, because it works exceedingly well and, hey, it's fun too.



**FRAME DETAILS**



See page 52 for complete Pugsley bike specs.  
See page 53 for complete Pugsley frame specs and geometry grid.

Color: Loaded Yellow or Engine Red

**NECK ROMANCER PUG** available as frame or complete bike

An alternative to the standard Pugsley. The Neck Romancer Pugsley is the stealth bomber in our fleet. The frame and fork are black with subtle black and gray decals. The rims are black. The spokes are black. Almost everything is black. But this bike isn't just an alternate color version of the standard Pugsley. Where the standard Pugsley sports 65mm-wide Marge Lite rims, the Neck Romancer utilizes our 82mm-wide single-wall Rolling Darryl rims to expand its tire footprint, increasing its traction and all-terrain floatation.

The increase in rim width puts the tire closer to the chain, so to avoid chain rub we spec'd this bike with our MWOD rings on a Mr. Whirly crankset. This provides all the chain/tire clearance necessary while retaining low- and mid-range gearing through the sticky and flying under the radar.

The Neck Romancer Pug is available as a complete bike (with a Moonlander fork) and as a frame, no fork. Choose the right one for you from our fat bike fork offerings...or pick something else (there are a few non-Surly options out there) and build up your ride to suit your specific needs.

We've made some spec changes (that's bike industry jargon for "we changed some parts") this year. Now the Neck Romancer is outfitted with a Nate 3.8" rear tire and a Larry 3.8" on the front, and we added Microshift thumbshifters which work great, especially when wearing mittens. The old front derailleur is a d-type, and we include the clamp adapter of course. Finally, we added an extra small (14") frame size.



**FRAME DETAILS**

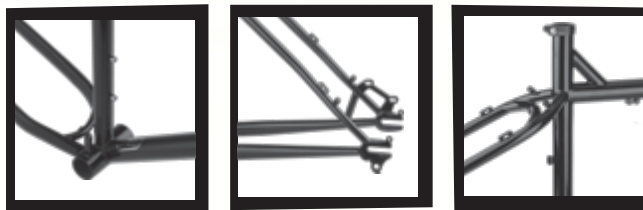

See page 52 for complete Neck Romancer bike specs.  
See page 53 for complete Neck Romancer frame specs and geometry grid.

Color: Burned Nougat

## LONG HAUL TRUCKER

available as frame or complete bike

Over the years our Long Haul Trucker touring frame and complete bike has developed a devoted following. People understand and appreciate the LHT's dependability and everyday riding comfort, whether they're cruising to the store or lost in the middle of nowhere.

The Long Haul Trucker was designed in all aspects to go the distance in relative comfort, and to be able to haul a bunch of stuff. Its low bottom bracket and long chainstays provide comfort and stability. We gave it ample tire clearance for larger tires (larger tires soak up a lot of road static) with room for fenders. The frame's tubing is thicker-walled and larger-diameter than standard road and sport-touring frames, and this pre-tunes it for the weight of cargo. And it's got all the braze-ons, from rack mounts to water bottle cage bosses to spare spoke holders. Like all our frames, it's made of CroMoly steel. You'll probably never need to have the frame repaired, but if you do you're more likely to find someone who can weld steel than someone who can weld titanium or aluminum. Repair carbon fiber in the middle of Mongolia? Good luck with that.

For the completes we chose components that balance technical ability, durability, and value. This is stuff that works well on a fully loaded tourer, will last you a while, and won't shoot holes in your wallet. Add whatever else you need, like racks and fenders.

The standard Long Haul Trucker is compatible with good ol' rim brakes. It's available as a frameset and as a complete bike, with 26" wheels in 42-62cm frame sizes, and with 700c wheels in 56-64cm. The fork has two sets of eyelets on the dropouts as well as at proper mid-blade height, and bosses built into the side of the crown. All this makes the fork compatible with most types of racks, and provides options how you can mount racks and carry your stuff.

Go somewhere. Do something. Ride a Long Haul Trucker.



See page 54-55 for complete Long Haul Trucker frame specs and geometry grid.

See page 56 for complete Long Haul Trucker bike specs.

Long Haul Trucker & Disc Trucker Colors: Smoggy Pearl or Blacktaular

## DISC TRUCKER

available as frame or complete bike

Our Long Haul Trucker enjoys a reputation as one of the best riding and most value-packed touring bikes out there. It's been around long enough to be tested and reviewed by lots of people, from casual enthusiasts to full on global touring bike nerds. But sometimes a combination of load, climate and terrain demands a bit more braking performance than a rim brake LHT provides. That's where the Disc Trucker comes in. Essentially it's a Long Haul Trucker with 51mm I.S. caliper mounts instead of rim brake mounts. But it's been specifically designed for the different forces discs introduce. And since we designed new rear dropouts to accommodate the disc forces, we made them so you can run discs, racks, and fenders with no jury rigging.

Most of the components on the complete bike are the same as the standard LHT, parts chosen for their balance of technical capability, durability, and value. For the Disc Trucker we chose Avid BB7 cable operated brakes for their proven reliability and ease of service, and Shimano XT M756 hubs with 6-hole rotor mounts. These hubs are durable and easy to maintain.

Your Disc Trucker is designed from the ground up to take you and a bunch of stuff just about anywhere you'd like to go. You'll need to outfit it with the extras you want, like fenders and racks. We don't include that stuff because everybody's needs are different, but from the casual commuter to the person who rides around the world more than once, the Disc Trucker is more than capable. It's a tool designed to help you get lost and find yourself.

## TRUCKER DELUXE

frameset only

Otherwise a standard rim brake, 26" wheeled LHT frame, the Trucker DeLuxe splits into front and rear halves, and is joined by brazed-in stainless steel threaded sleeves commonly known as S&S Couplers (S&S Machine is the company who invented and manufactures them). S&S Couplers allow the bicycle (without bags or racks) to fit into a case within airline regulation dimension for standard size luggage, meaning your bike can fly at the same price as a normal piece of checked luggage. We sell this as a frameset only, and advise that to properly make use of the option this frame provides, a certain level of mechanical aptitude is required. You have been warned.

- 26" wheel only, framesets only
- Sizes 42, 46, 50-62cm



So there you go. Lots of options, lots of sizes. As we said when we first introduced the Long Haul Trucker touring frameset, nothing is quite as epic as a really long bike ride. Long Haul Trucker frames are designed from the ground up for exploring that idea. Pack up, sell the car and go.

### FRAME DETAILS

Long Haul Trucker



Disc Trucker



Trucker DeLuxe



See page 54-55 for complete Disc Trucker frame specs and geometry grid.

See page 57 for complete Disc Trucker bike specs.

See page 54-55 for complete Trucker Deluxe frame specs and geometry grid.

Trucker DeLuxe Color: Dave's Frozen Tears

# PACER

available as frame or complete bike

Behold the Pacer. For years we sold it only as a frameset. It was understated, didn't draw a lot of attention to itself, but it rode great and people who rode one loved it.

The Pacer is not what most race-inspired roadies seem to drool over. It isn't on the cutting edge of design, it isn't made of the ultra-light, super-expensive materials, and it isn't festooned with lots of bright colors and graphics. Rather, it is a road bike made of our favorite material, CroMoly steel, using frame geometry that makes it fast and efficient like a road bike should be. But this is not a racing frame. This is a frame meant for all-day rides. There are a lot of other road frames out there that are flashier, more exotic, and full of promises most riders only dream of fulfilling. The Pacer doesn't make promises. It's simply a great riding steel frame.

We decided to offer it as a complete bike to make it easier for folks to try one. It's comfy but responds when you push hard on the pedals. It's got plenty of tire clearance for larger tires. Since tire casings flex before the frame, higher volume tires take the edge off the bumps and jangles which otherwise can harsh your ride. We use the complete 28mm tires, a good all-around size that will still allow you to add fenders if you like. As you might expect, we built it up with a parts kit that is more than capable, but not snobbish or unnecessarily expensive.

The Pacer reminds us, quietly, that there is a road bike out there for the rest of us.



## FRAME DETAILS



Color: Sparkleboogie Blue

See page 58 for complete Pacer frame specs and geometry grid.

See page 59 for complete Pacer bike specs.

# CROSS-CHECK

available as frame or complete bike

The Cross-Check was the third frame we ever offered, and we offered it as a complete bike a year after the introduction of the frame. It's a cyclocross bike by category, but we try to design a lot of versatility into our stuff. You can ride it on the road or off. It's got lots of space for fat tires and for fenders. It does as good a job getting you across the country as it does getting you across town. If you get bored with how it's built, change it. It can be a geared bike, or a singlespeed or fixed gear. Big tires? Check. Skinny tires? Check.

Neither the frame nor the component spec of the bike have changed much since we introduced it almost a decade ago because...well, why should it? We have made a few changes and updates over the years when those changes were either necessary or just plain a good idea. For instance, we added mid-blade eyelets to the fork for mounting a front rack. This isn't a touring bike per se, but it will handle lighter touring loads, and a front rack can make that easier. This year we gave it a new fork crown too, with threaded eyelets for adding...things. Need a place to mount a spare light? Got a mini rack that needs anchor points? You're covered.

The one major change we've made is that this year we're offering 2 versions of the complete bike. First there's the 2 x 9 you've come to know and love. We switched to Microshift bar-end shifters, but otherwise it's the same basic mix of components that work well and won't dent your piggy bank too bad.

We've added a freewheeling singlespeed version to the line-up. Avid Single Digit 5 v-brakes, Surly Ultra New model hubs, 42mm Continental Tour Ride tires, a Salsa MotoAce riser bar, and 42 x 17 gearing. The frame is the same as the other one, so you can deck it out with racks and fenders, and you can change it up later if the desire arises to make it into, say, a fully geared day tripper.

There's a reason we still offer the Cross-Check after all these years. The frame is comfy and tough as nails. We continue to hear from people who have made the Cross-Check their default go-to bike simply because it performs so astonishingly well. It's one of the best riding, most versatile bikes around.



## FRAME DETAILS



Geared Color: Hospital Foam or Gloss Black  
Singlespeed Color: Blark Due

See page 60 for complete Cross-Check frame specs and geometry grid.

See page 61 for complete Cross-Check bike specs.



# STEAMROLLER

available as frame or complete bike

We offer the Steamroller as a frameset and also as a complete bike. The frame, like all our frames, is made of 4130 CroMoly steel. Steel is springy and durable, providing a ride feel you don't get from aluminum or carbon fiber, at a price titanium can't match. True, our frames are not the lightest out there, but then they're not supposed to be. Instead, they are a balance of excellent ride quality and durability.

It was designed as a dedicated fixed-gear, but its geometry is closer to a road bike than a track bike. It'll take tires up to about 38mm. It's got nothing in the way of braze-ons except a set of water bottle cage mounts. You could add front and rear brakes and a freewheel if you really want, but you'll need to use full-length rear housing.

This year we changed the component spec of the complete bike. We gave the Steamroller big shoes, a wide upright-ish bar, brakes, and we chose a gear ratio more suitable to paths as well as roads. It sports Surly hubs (the rear is outfitted with our fixed cog and lockring, and is threaded on the other side for a singlespeed freewheel should you want to run one) and our new Open Bar handlebar, in addition to a selection of components designed to work well and love you long time without punching you in the wallet.

As you've probably noticed, there are a whole bunch of fixed-gears out there nowadays, most of them either actual track bikes (not especially suited to streets and definitely not suited to paths) or modified fixed-gears that people ride like BMX bikes. We made ours more like an all terrain fixed-gear, an updated version of bikes from the old daze, long ago, when all bikes were fixed-gears, when people raced on flat oval dirt tracks, and when bad roads were the norm. The Steamroller is right at home in these conditions. What won't it do? Bar spins.



## FRAME DETAILS



See page 62 for complete Steamroller frame specs and geometry grid.

See page 63 for complete Steamroller bike specs.

Color: GrayGreen or Superblack

# BIG DUMMY

available as frame or complete bike

The Big Dummy is designed for carrying cargo. Like all our frames, it's made of steel and it's got lots of little touches that you've come to love in a Surly, like clearance for bigger tires and common component sizing.

It's built around the Xtracycle design platform, which means that Xtracycle or Surly accessories can be added depending on what you want to carry, or you can build your own to meet whatever hauling need you have. However, being a dedicated single-piece frame instead of an add-on to an existing bike, it's more stout and resistant to torsional flex, and this makes it resistant to fatigue and failure.

Figure on being able to carry about 200 pounds (90kg) of cargo. The load weight, and how it's loaded, will affect the handling somewhat. Also plan on using gears, especially as cargo weight increases. This may seem obvious, but as you get comfy with it you'll use your full range of gears as never before.

One of the funny things about the Big Dummy is that it doesn't ride quite like you might think. Sure, it's a little longer, but mainly it rides like a bike. It's smooth, maneuverable, even nimble. Are you riding light and want to hit some singletrack on the way home? Do it. And if you get a call from your better half asking you to pick up some groceries, or you see a nice lamp at a garage sale, you're all ready. Lots of people bought one to use once in a while and began using it as their everyday ride.

The frame can be built up lots of different ways to suit your needs and budget. The complete bike option has reliable but understated components to help keep the price down while still retaining durability and quality components Surly is known for.



## FRAME DETAILS



See page 64 for complete Big Dummy frame specs and geometry grid.

See page 65 for complete Big Dummy bike specs..

Color: Tar Pit Black

# BILL & TED TRAILERS

There are quite a few options these days for trailers that carry kids or dogs, luggage, groceries and other relatively small loads. Trailers are nice because they can be detached when not in use, but most trailers can't haul much weight and the ones that do suffer some design drawbacks such as incompatibility with many kinds of bikes. Conversely, there are quite a few cargo bikes that can haul bigger loads, but cargo bikes meant for a lot of weight can be difficult to load, are sometimes difficult to ride (sometimes due to the bike's design, and sometimes due to the sheer weight of the bike itself), and require a lot of space to store. We felt we could help bridge the gap, so we designed two trailers meant to haul a lot, to be easy to use, and to work with a bike you have already.

We make two bed lengths so you can find one that suits your needs. Bill is the long bed and Ted is the short bed (shorter name, shorter trailer, see?). The beds and hitch are constructed mainly of TIG-welded 4130 CroMoly steel. CroMoly steel is tough and durable and well-suited to this task. We used 304 stainless steel hardware where appropriate to ensure corrosion resistance and a long life. The beds have threaded eyelets for bolting down decking, corner posts, or creating other custom accessories using readily-accessible materials from your local hardware store, lumberyard or home improvement store.

The wheels are 16", keeping cargo low to the ground. 16" wheels are also stronger than larger diameter wheels favored by many trailers. We designed our own hubs to meet the requirements of this frame. The rims are double-wall with stainless eyelets. The spokes are stainless steel, radially laced. Combined with smooth, easy rolling 1.95" tires, these are stout wheels designed specific to their purpose.

Our hitch system is designed to be as universal as possible. Regardless of the configuration of your bike frame, our hitch will likely fit your bike. It doesn't clamp to the bike's frame tubes. Instead, it attaches using a proprietary axle skewer or thread-on axle nuts. The Surly trailer hitch works with full-suspension frames, disc brakes, rear racks and fenders. It adjusts to accommodate hub widths from 120-145mm and allows you to align the centerline of the trailer on the centerline of the bike. It will work with bikes that have wheels as small as 20" and as large as 29" while keeping the bed level with the ground. This is especially important when you are hauling long items that hang off the back of the trailer (lumber, tubing, ladders, etc.).

There are some things to learn about using a trailer like this to haul stuff. You'll probably want to use a bike with gears, for example. As well, learning to load it right becomes more important as cargo weight increases. Load it over the axles, balancing the load. Too much weight on the hitch (tongue weight), or too much weight hanging off the back, and the bike's handling will be compromised, making it harder to control and potentially damaging your bike, the trailer, or you. Finally, we do not recommend ever carrying people or furry friends on Surly trailers. Sure it might be fun, but someone could get seriously hurt and that's not fun at all.

**Tubing:** 4130 CroMoly steel. TIG-welded

**Hitch-to-frame compatibility:** Surly trailers connect to your frame via Surly mounting hardware. The hitch is width adjustable to fit most frames from 120-145mm O.L.D. (rear hub) spacing

**Bicycle wheel compatibility:** The hitch will fit a wide variety of wheel diameters, from 20" up to 29", accommodating up to a 29 x 2.6" tire. Sorry, it won't work with fatbike rims and tires, such as our Large Marge or Larrys

**Platform dimensions:** Bill (long bed) = 63 x 24" (1608 x 610mm), Ted (short bed) = 32 x 24" (813 x 610mm)

**Maximum tongue load:** 50 lb (22.7kg)

**Maximum total load:** 300 lb (136kg)

**Braze-ons:** 5 x 1mm threaded barrels for securing a platform; corner stake eyelets

**Trailer tire clearance:** Our trailers come with 16 x 1.95" tires. There is clearance for 16 x 2.5" tires

**Color:** Silver with black hitch

**Weight (includes hitch & wheels):** Bill (long bed) = 37 lb (16.8kg), Ted (short bed) = 30 lb (13.6kg)

## BILL BED

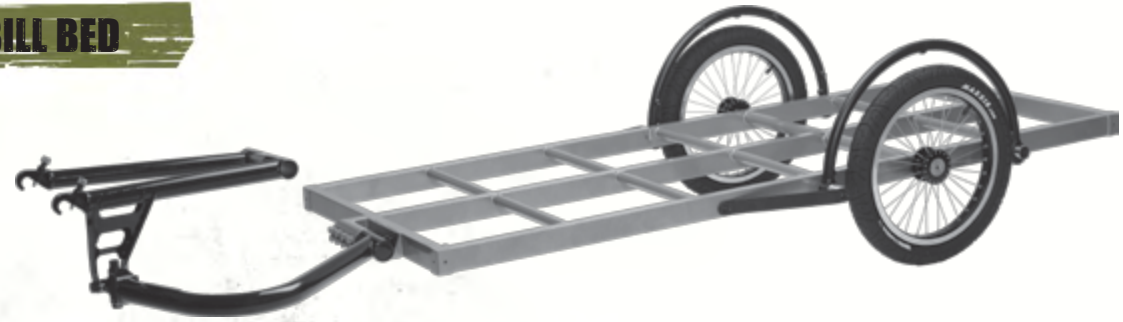

## TED BED

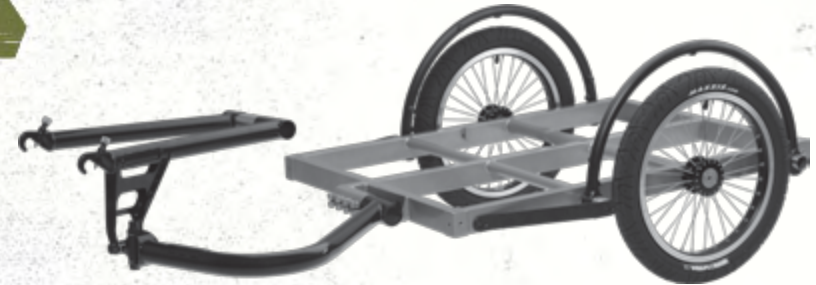

The frame is a solid unit constructed of welded CroMoly steel rectangular tubes. The hitch can be adjusted to level the bed, making it easier to carry long items.

## DETAILS



The wheel arches keep cargo from shifting into spokes and provide load-bearing support for items that don't fit between them. Threaded bosses, in the wheel covers, provide mounting points for fenders and spoke guards (not included).



The hitch is highly adjustable to fit most types of bikes and a wide variety of wheel diameters and hub widths.

## BILL & TED ACCESSORIES

### BILL AND TED CORNER STAKES

These corner stakes are designed to mount quickly and easily to your Bill or Ted trailer. Install them and then add planks, plywood, tarpaulin, plastic panels, or what-have-you for box sides, or install just the corner stakes to keep large and long items in place. They feature multiple wall mounting-hole locations to accommodate whatever material you're using for walls as well as multiple tie-down locations to lash cargo to the bed or in the box. Sold as a set of 4. Made of aluminum. Blacque, Jacques.

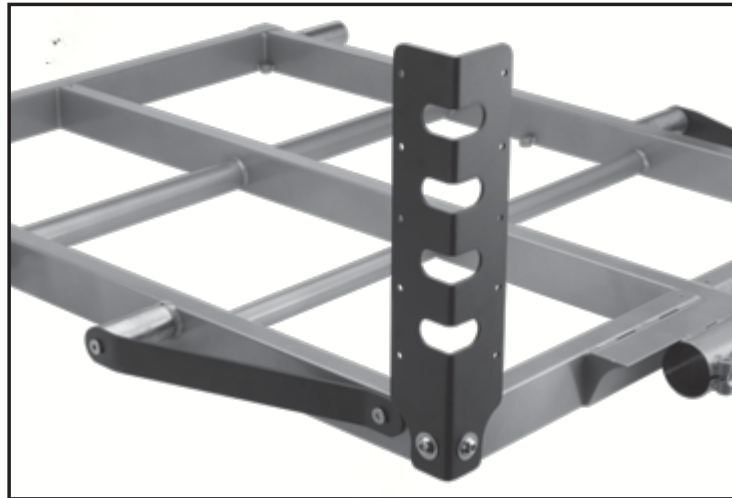

### FENDERS & WHEEL GUARD KITS

Adding fenders and wheel guards to your Bill or Ted trailer is simple and easy with these pre-fab kits. One kit includes two fenders to keep wheel spray under control and 2 wheel guards to keep stuff from migrating into your spokes. Made of recycled high density plastic. Stainless bolts not included...those came with your trailer. You've lost them? Get get some M5 x .8mm stainless bolts and everything will be o.k.

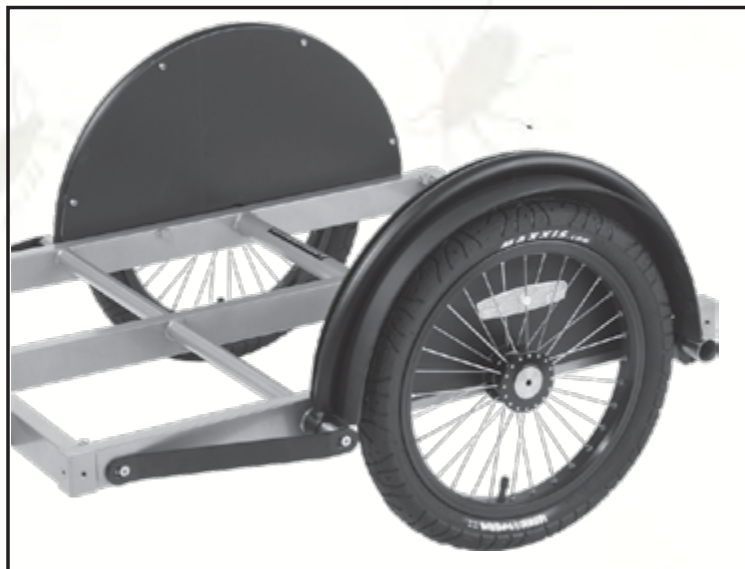

## TIRES

The majority of our tires are meant for fat bikes such as our Pugsley and Moonlander. Most are 26 x 3.8" or 4.8". We also offer a tire called the Knard 29 x 3", which is not, technically speaking, a fat bike tire. Regardless, our love of fat tires is such that we don't feel the need to reinvent tires already out there but rather to supply tires that others simply don't make. We design and test them to be the best rolling tires available. Just be warned that all the tires we make require a frame or fork that will accommodate their Rubenesqe proportions.

### ENDOMORPH 3.7"

Endomorph was the first tire we offered. The chevron-paddle tread is designed for soft conditions like sand and packed snow. Endomorph measures about 3.7" on a 65mm wide rim. You can gain a bit more footprint by using a wider rim, though be careful as many frames won't accept an increase in tire or rim width happily. Its casing is 120tpi, increasing suppleness and durability over previous versions (and over the stock 27tpi version that comes with our Pugsley complete model). Many folks use Endomorph in the rear with a Larry tire in front for improved steering.



### LARRY 3.8"

Roughly 3.8" on a 65mm rim. The tread is a series of pointy darts, vastly reducing steering drift over the Endomorph. Works well as a front, and also as a rear in lot of conditions from packed snow to loose gravel. It is offered in 120tpi, and is available with wire or Kevlar bead.



### BIG FAT LARRY 4.7"

The Larry tread applied to a very large casing. This tire measures about 4.7" on a 100mm rim! What does this mean to you? Float, float, float, my friend. Traction, Jackson. Larry tread provides good grab and steering in a multitude of conditions. For those of you looking for the maximum in traction and floatation, you have just found the mother lode. Available in 120tpi casing, in wire or Kevlar bead.



### NATE 3.8"

We named this tire for our friend Nate, who is himself large and aggressive. A major departure from Endomorph and Larry's more shoot-n-drift tread characteristics, Nate is a shred-your-face-off, run-over-anything, kung fu grip knobby tread pattern. The casing is round and supple at 120tpi. Tall, widely spaced knobs are siped for added grip and compliance. The knobs' wide spacing means they dig deep and still shed the crap you're riding through. The tread is wrapped around the sides of the tire some, providing good knob contour even on very wide rims, which in turn allows good off-camber traction. Available in wire or Kevlar bead.



### BLACK FLOYD 3.8"

Sometimes a lot of tread isn't necessary. Sometimes, even on a fat bike, you don't want to run real low pressure in your tires. Sometimes even fat bikes want to stretch their legs and run. Enter Black Floyd. Black Floyd allows you to pump up the pressure and cruise like a '71 El Dorado. The casing is designed to work best on 65mm rims. The tread is comprised of tightly spaced low profile "bricks". Naturally, it's designed for street and hardpack conditions. We expect the unicyclers will dig this one too. Your ideal pressure will vary according to what you want to ride, but in those places where less is more, Black Floyd will transform your fat bike into a road warrior. And soon, we hope, they'll be available in whitewall. Hells yeah. 120tpi casing, in wire or Kevlar bead.



# TIRES

## KNARD 29 X 3"

These are not, technically speaking, fat bike tires. Most fat bike tires are nominally 26" (559mm bead seat diameter), and they're all around 4 or 5". They're great for traction and float, but a bit bouncy and sluggish. The Knard is of a slightly different ilk, known as 29+. The Knard comes in at a svelte 3" and is made for a 29" (622mm) rim. The Knard's block tread has been carefully researched, designed, and tested. It's shaped just slightly eggy to maximize traction on corners while keeping rolling resistance low on straightaways, with an unnoticeable transition between the two. The casing provides a malleable but firm platform, surprisingly adjustable by adding or releasing a pound or two of air pressure. All of which allow traction and float unseen in 29ers until now, and that's saying something. Designed to work best with our Rabbit Hole rim and Krampus frame, this tire will play nicely with rims down to about 35mm, but your frame must have clearance, Clarence.



## KNARD 26 X 3.8"

The same tread as our new Knard 29 x 3" tire, a web of closely spaced blocks designed to grab terrain and hold it hostage until it's done with it. Made on the same casing as our Nate and Larry tires, these tires occupy a unique place in the line-up: faster, less loose-dirt-and-mud oriented than the Nate 3.8, more point-n-shoot than Larrys or Endomorphs, and definitely more dirt than Black Floyds. 120tpi casing, Kevlar folding bead.



## BUD & LOU 4.8"

Our latest 4.8" tires designed for 559mm ("26inch") super wide rims such as our 100mm Clown Shoes, Bud and Lou are, to quote one of our designers, "designed as a front and rear pair." Exciting stuff. He goes on to say, "They are meant to be the wildest, gnarliest, oh my god my face is bleeding tires available. The footprint is massive (larger than Big Fat Larry) and the tread is aggressive. This combination is going to keep you moving in the most demanding soft conditions any bicycle will attempt. You could say these tires are 4.8" Nates, but they are so much more than that." For example, their tread height is a staggering 7mm (6mm on Nates, 4.2mm on Larrys). They measure about 30.8" in diameter, inflated, and their casing is 120tpi with a Kevlar folding bead.



# RIMS

All our rims are wider than 'normal,' and some require specific dishing (or offset) to match certain fat bike frames. While it isn't rocket surgery to build a wheel like this or to have someone build one for you, some folks nonetheless find it more desirable to simply buy a complete wheel already built. We are not heartless sadists and we are half-hearted capitalists, so it only makes sense that we offer complete wheels built with rims we make: Clown Shoes, Rolling Darryls, Marge Lites, and our latest, the 50mm Rabbit Hole 29+ rim.

## LARGE MARGE

The first rim design we offered, Large Marge is 65mm wide and double walled. The double wall-ness makes it strong like ox, both durable and resistant to flex. If you're a bruiser, this is the rim for you. We offer Large Marge in two extrusions: one is symmetrical for frames without side-offset; the other is asymmetrical to allow even spoke tension in offset frames such as our Pugsley. Some are available with weight-shaving cutouts (we call these XC), some without (DH), and we offer them in 32- and 36-hole. Large Marge plays best with 3.7 and 3.8" tires and frames such as our Pugsley.

**ETRTO:** 559mm

**Weight:** 1,050g (XC), 1,150g (DH)

**Color:** Black

**Large Marge available in:**

DH symmetrical, 32 & 36h

DH offset, 32 & 36h

XC symmetrical, 32 & 36h

XC offset, 32h only

**Note:** We offer special Large Marge rims that are offset-drilled to give more dish to the disc side of Pugsley wheels.

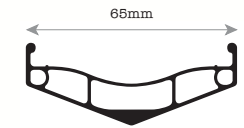

**Standard Marge**

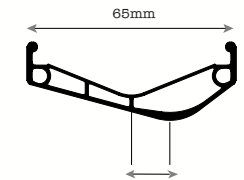

**Pugsley "offset" Marge**



## MARGE LITE

65mm wide like Large Marge, Marge Lite shaves a lot of weight over regular Marges while retaining torsional stiffness. This rim, like our Rolling Darryl and Clown Shoe rims, utilizes a 64 dual-spoke hole pattern. Lace 32 holes all on one side when building for frames with offset, such as our Pugsley and Moonlander. Lace 32 holes skipping side to side for non-offset frames or forks.

**ETRTO:** 559mm

**Weight:** 690g

**Color:** Black anodized

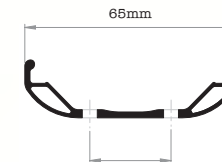

### ROLLING DARRYL

82mm wide single wall. Same 64 dual-spoke hole design as Marge Lite. This rim will increase the footprint of 3.8" tires compared to 65mm rims. Cutouts shave weight and allow your rimstrips to show through, which looks pretty cool we think. Note: Use of this rim will increase the width of your tire and may cause the chain to rub the tire in the lowest gears, so either remove a couple cogs and add some spacers behind the cassette or else get you some of our Mr. Whirly Offset Double chainrings.

**ETRTO:** 559mm  
**Weight:** 860g  
**Color:** Black anodized

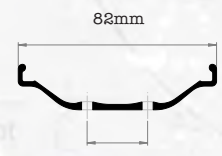

### CLOWN SHOE

100mm wide! Holy moley! Designed for use with 4.7" tires such as our Big Fat Larry, and of course a frame with appropriate clearance such as our Moonlander. Same 64h dual spoke pattern as Marge Lite and Rolling Darryl rims. Cutouts for weight reduction and rimstrip pimping.

**ETRTO:** 559mm  
**Weight:** 960g (!)  
**Color:** Black anodized

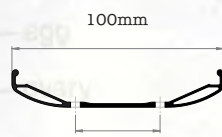

### RABBIT HOLE

50mm wide, and technically a single wall with internal tubes to buttress it, the Rabbit Hole is designed in conjunction with our Knard 29 x 3" tire and Krampus frame to provide a wide, stable footprint that walks the line between the traction and float of fat bike rims and the speed and even greater obstacle crushing approach angle of 29ers. Its weight is more than a standard 29er rim but less than a fat bike rim, so there you go. It's made of high quality 6061-T6 aluminum with a welded seam, and comes to you round and true because that's part of what makes strong wheels. The Rabbit Hole will also spread 2.3-2.4" tires, but your frame needs to have enough space. Available in the same 64 dual row spoke holes as our other rims with weight-shaving cut-outs.

**ETRTO** (tire bead seat diameter): 622mm  
**ERD:** 615.5mm  
**Weight:** 699g  
**Color:** Black Anodized or Shiny Silver

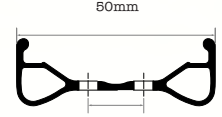

## COMPLETE WHEELS

While it isn't rocket surgery to build a wheel with rims like ours, all of them wider than 'normal,' and some requiring specific dishing (or offset) to match certain fat bike frames, some folks nonetheless find it more desirable to simply buy a complete wheel already built. We are not heartless sadists and we are half-hearted capitalists, so it only makes sense that we offer complete wheels built with rims we make: Clown Shoes, Rolling Darryls, Marge Lites, and our latest, the 50mm Rabbit Hole 29+ rim.

Our wheels are laced, tensioned and finished by hand to exacting standards using high quality DT Swiss spokes and nipples, and are offered with a variety of high quality, purpose-chosen hubs in various O.L.D. spacings and frame-matching offsets. This means we have a lot of wheels for you to choose from, far too many to list here. Contact us to find out what all your options are and how to get your hands on them. Our email address or phone number is around here somewhere.



## TOOBS

We make tubes to fit 26 x 3.7-4.8" tires in 1.3mm and lighter weight 1.0mm thicknesses. We also make tubes to fit 29 x 2.5-3.0" tires. All are made of butyl rubber, all have presta valves, and all will easily float a small dog.



## RIM STRIPS

We offer two basic varieties of rimstrips.

The first is an adhesive backed nylon made for us by ROX USA. It is sold singly (buy one for one rim). Use this on our good ol' Large Marge rims.

We also produce rimstrips for our Marge Lite, Rolling Darryl, Clown Shoe and Rabbit Hole rims. All are made of PVC and are offered in red, white, blue and good old black. Sold singly.

- ROX:** 50mm wide for 65mm rims
- PVC:** 38mm for 50mm rims
- 46mm for 65mm rims
- 64mm for 82mm rims
- 75mm for 100mm rims



## O.D. CRANK—THE OFFSET DOUBLE

We designed our O.D. crankset to offer frame and tire clearance while maintaining a reasonable q-factor (pedal stance). Maximizing the distance between the chain and the tire is important on fat bikes such as our Pugsley and Moonlander, or if you're running really big tires and rims on some other bike (like our new Krampus, for example). With normal cranks, wide tires on wide rims can rub the chain when in the lowest, or farthest-inboard, gear combinations. Like our MWOD crank, the O.D. crank doesn't just add a longer spindle to move the rings outboard. Rather, it does away with the big ring of a standard triple and moves the middle and granny rings to the outer and middle positions. This effectively moves the rings outboard without moving the arms outboard too. The O.D. is a simple, dedicated version of this idea. Neato!

Forged of 7000 series T6 aluminum, the O.D. crank is a 2-piece, with spindle embedded inextricably in the drive side arm. It's a dedicated 2x, although its chainline is outboard a bit compared to standard mountain cranks, and it is 9 and 10 speed compatible.

We offer versions to fit 73mm bottom bracket shells and two versions to fit 100mm BB shells: one for Pugsleys (to accommodate the offset required for 4" tires) and one for Moonlanders (frames offset for 5" tires). Each of these will be available as complete cranks (arms, spindle, rings, and bearings) in 170mm and 175mm lengths. 180mm will be available too, but as arm sets only. Completes for 73mm BB shells will have 39/26t rings. The 100mm BB shell versions will have 36/22t rings, and we'll also offer a 33t and 20t rings separately. These chain rings are designed to shift best in specific combinations....change to a 39/22t, for example, and your shifting will suffer. The bearings on which they spin are also worth mentioning: we've upgraded our bearings on these and our Mr. Whirly and MWOD cranksets to aftermarket Enduro bearings with double labyrinth seals, meaning they actively shed and stay clean of dust, muck, and grime, even in wet and muddy climates.

All O.D. cranks are available in black.



### COMPLETES:

170 and 175mm for 73mm BB, 39/26t rings

170 and 175mm for Pugsley 100mm BB, 36/22t rings

170 and 175mm for Moonlander 100mm BB, 36/22t rings

### ARMSETS:

170, 175, and 180mm. All accept 58mm BCD inner rings and 94mm BCD outer rings.

### RINGS:

Our rings are sold individually, not as sets. They are designed to work in specific combinations. The number in parenthesis after each ring size its ideal mate.

58mm BCD (stainless steel): 26t (39), 22t (36) and 20t (33)

94mm BCD (hard anodized aluminum): 39t (26), 36t (22), and 33t (20)

## MR. WHIRLY

The Mr. Whirly crankset system is the most versatile bicycle crank on the market. You may never need the versatility it offers, but if you're like us the possibility of swapping it between very different kinds of bikes, and configuring it the way that best suits you, is an option we like a lot.

For most people, the easiest way to get to know Mr. Whirly is through one of our complete crankset options: singlespeed, standard mountain triple, Pugsley triple or Moonlander offset double. Each complete crankset is available in two arm lengths. Complete cranks are available in black.

But let's dig under the surface a little. Mr. Whirly chainring spiders are removable from the arms. They're available in three common bolt circle diameters, so you can swap them around according to what rings you have or what is best suited to your requirements. And we offer four different spindles to fit a variety of frames. Want to use that 94mm chainring in your parts bin for a singlespeed project? Do it. Later you can swap spindle and spider and make it a commuter double on another frame, or throw it on your Pugsley or Moonlander. As your needs change, Mr. Whirly can change with you.

Mr. Whirly arms and spiders are forged aluminum. Cranksets are available in three lengths; armsets in five lengths. Spiders come in three common bolt circle diameters (BCDs). Spindles are CroMoly steel, and come in four different lengths to work with a wide variety of frames.

What does all this mean to you? Options. Set up Mr. Whirly for the riding you do. Replace bits if they break instead of replacing the whole crankset. Mountain bike with it. Tour with it. Commute with it. Mr. Whirly isn't stingy with his love.

### CRANKSETS

- Singlespeed:** 33t Surly stainless steel ring on 94mm spider. Spindle for 68/73 shells. 175 or 180mm. Black
- Mountain Triple:** 22/32/44t rings (aluminum) on 94mm spider. Spindle for 68/73mm shells. 170 or 175mm. Black
- Pugsley Triple:** 22/32/44t rings (aluminum) on 94mm spider. Pugsley spindle for 100mm BB shells. 170 or 175mm. Black
- Moonlander MWOD:** 22/36t rings (aluminum and stainless steel). Moonlander spindle for 100mm BB shells. 170 or 175mm. Black

### COMPONENT BITS

- Armsets:** 165, 170, 175, 180 or 185mm. Silver or Black
- Spiders:** 58/94mm, 58/104mm, 58/110mm BCD. Silver or Black
- MWOD Ringsets:** 20/32t & 22/36t
- Spindles:** **All Mr. Whirly spindles are CroMoly. Available in:**
  - Short to provide 47.5mm chainline on 68 & 73mm BB shells
  - Medium to provide 50mm chainline on 68 & 73mm BB shells
  - Pugsley to fit 100mm BB shells on frames with 17.5mm lateral offset
  - Moonlander to fit 100mm BB shells on frames with 28mm lateral offset
- Extras:** All small hardware bits, including bolts, caps, cups and bearings

### MWOD EXPLAINED

The MWOD (Mr. Whirly Offset Double) system is a modified spider and ring combination for Mr. Whirly cranks, designed specifically for use on bikes running very large tires and rims, such as our Moonlander. Standard triple ring cranks can allow the chain to rub the rear tire when shifted into the lowest gears. On a bike made for crawling through the thick and sloppy or over insane terrain, these low gears are essential and cannot afford to be compromised.

To solve this problem, the MWOD system ditches the big ring. The outer (largest) chainring on a mountain triple is rarely used with extra wide tires. With the outer chainring removed, the granny and middle chainrings are shifted outboard to the old locations of the middle and outer chainrings. This shift effectively gains you around 7mm of tire clearance at the chain without increasing your Q-factor and without losing your crawling gears.

With the rise in popularity of so-called fat bikes, there now exist lots of tire, rim and frame options, creating a No-Mans-Land of mostly but not completely compatible combinations. While MWOD complete cranks are set up specifically for Moonlander frames (which are designed with lateral 28mm offset to provide clearance for 100mm rims and 4.7" tires), the MWOD system also works with other frame and wheel combos. Say you want to run 82mm rims on your Pugsley. The frame's offset is designed around 65mm rims and 3.8" tires. Wider rims will place the tire closer to the chain in its lowest gear. If you've got a Mr. Whirly on your Pug, you can install the MWOD ring set and just like that you've got a bigger footprint and no chain-on-tire rub.

Get it? Got it? Go for a ride.

## STAINLESS STEEL CHAINRINGS

Most chainrings on the market are made from aluminum. Although it's light and stiff, aluminum wears out fairly quickly in the high-friction world of a chain-driven bicycle drivetrain. Our chainrings are made from 304-grade stainless steel. They're ideal for singlespeed, fixed-gear, or tandem timing chain applications in part because stainless doesn't wear as fast as aluminum (and of course it doesn't rust either). This is of some importance on a singlespeed system, where the chain wear isn't shared by other chainrings. Long-wearing parts mean more time on your bike and more money in your pocket. Our stainless chainrings are not ramped or pinned.

**Color:** Natural Silver

**Compatibility:** Designed to work with 3/32" (derailleur type) chains. Please note that many 10-speed and some 9-speed chains may fit tightly at first

**Sizes:** 94mm BCD x 30, 31, 32, 33, 34, 35 & 36t

104mm BCD x 32, 33, 34, 35 & 36t

110mm BCD x 34, 35, 36, 38, 39, 40, 42, 44, 46, 47, 48, 49 & 50t

130mm BCD x 38, 39, 40, 42, 44, 46, 47, 48, 49 & 50t



## MWOD CHAINRINGS

MWOD chainrings convert your Mr. Whirly crankset into an offset mountain double crank, allowing you to run extra wide rear tire and rim combinations (4.7" tires on 100mm rims, for example, or 82mm rims on your Pugsley) while avoiding chain-on-tire rub. MWOD rings move the granny and middle rings to the middle and outer positions of the crank, effectively increasing tire clearance at the chain without increasing your Q-factor and without losing your crawling gears.

MWOD granny rings are stainless steel, the bigger rings are aluminum. The small ring bolts to the big ring, and the combo then bolts directly to the 58mm BCD mounting holes on Mr. Whirly cranks. They're available in 20/33t and 22/36t.

**Color:** Natural Silver



## O.D. CHAINRINGS

Our O.D. chain rings we developed for our O.D. crankset. They are standard 58mm and 94mm BCD rings, the small ones in stainless steel, the bigger ones in aluminum. They are designed to work in specific combinations (see below), but will still work in other combos if you don't mind slightly slower shifting. We sell them individually, not as sets. The number in parenthesis after each ring size is its ideal mate.

**Color:** Natural Silver

**Sizes:** 58mm: BCD (stainless steel): 26t (39), 22t (36) and 20t (33)

94mm: BCD (hard anodized aluminum): 39t (26), 36t (22), and 33t (20)

## ULTRA NEW HUBS

Ultra New hubs look much like their predecessors. In fact, the hub shells have not changed at all. They remain 6061-T6 forged and machined aluminum alloy with medium-height flanges. What's Ultra New about these hubs are their guts.

Ultra New hubs use hollow axles of our own design mated to thread-in wheel fixing bolts, as opposed to the nutted axles of our previous hubs. Hollow axles make conversion to quick release super easy (remove bolts, insert QR skewer, install wheel into frame or fork, ride). All Ultra New hubs come with fixing bolts, but all are QR compatible without axle conversion or any other extra crap. Neato. The axles are made of CroMoly steel, while the fixing bolts are 10.9 stainless steel (i.e. high grade) for corrosion resistance, high strength, and good looks, and the bolts tighten and loosen with a 6mm hex wrench.

Bolt caps and 'cone' nuts are also stainless steel, and are heavily knurled for good bite, reducing the chance for your wheel to slip in the frame under high load. The cones and dust caps interlock to maintain axle stiffness. Ultra New hubs spin on non-adjustable 6901 model bearings. Throw your wheel on the bike, tighten the bolts and ride.

One other thing you might like to know: All the Ultra New hardware will retrofit to New hubs. That is, we sell kits to completely transform your old New hubs into Ultra New hubs, complete with new axle, bolts, bearings, and the rest of the Ultra New hardware. Find the right kit for your New hub, install, and go.



**Freewheel Threading:**

English 1.37" x 24tpi

**Fixed Cog Threading:**

English 1.37" x 24tpi

**Lockring Threading:**

1.29" x 24tpi LH

### FRONT DISC & NON-DISC

Silver	32h	100mm O.L.D.
Black	32h	100mm O.L.D.
Silver	36h	100mm O.L.D.
Black	36h	100mm O.L.D.
Silver	36h	100mm O.L.D.
Black	36h	100mm O.L.D.
Black	48h	100mm O.L.D.
Silver*	32h	135mm O.L.D.
Black*	32h	135mm O.L.D.

(\*No cog or freewheel threading)

### REAR, 130MM (ROAD SPACING), NO DISC

Black	32h	Fix/Free
Silver	32h	Fix/Free

### REAR DISC, 135MM (MTB SPACING)

Silver	32h	Freewheel
Black	32h	Freewheel
Black	32h	Fixed
Silver	36h	Freewheel
Black	36h	Freewheel

### REAR, 120MM (TRACK SPACING), NO DISC OPTION

Silver	32h	Fix/Fix
Black	32h	Fix/Fix
Silver	32h	Fix/Free
Black	32h	Fix/Free
Silver	36h	Fix/Fix
Black	48h	Fix/Fix
Black	48h	Free/Free

### REAR NON-DISC, 135MM (MTB SPACING)

Silver	32h	Free/Free
Black	32h	Free/Free
Silver	32h	Fix/Free
Black	32h	Fix/Free
Silver	36h	Free/Free
Black	36h	Free/Free
Black	48h	Free/Free
Black	48h	Fix/Fix

**HEY!** Fixed cogs and English threaded SS freewheels use the same size threads. Fixed-gear hubs have a second set of smaller diameter, reverse-direction threads outboard of the cog threads. Surly does not endorse the use of fixed-gear cogs of any kind without the use of a properly installed lockring. We know some jerk on MTBR.com said he did it and ain't been hurt yet, but lockrings are important. You have been warned. If you hurt yourself because you didn't use one, you deserve what you get.

## DINGLE COGS

Dingle Cogs are part of a different concept for fixed-gear drivetrains. Having two cogs on the back means you have more options for gear changes when the conditions demand it. For instance, say you want to ride your off-road fixie from your house to the trailhead, but your gear combo is either too high for the dirt or too low for the road. With a 17/19t Dingle on the back, pick two chainrings that are two teeth apart, like a 44t and a 42t. When you change from the outer (44:17t) gear combo to the inner (42:19t), you'll have a much better off-road gear and your wheel position will not change. This maintains effective chainstay length so you won't have to worry about having too much or too little dropout length to accommodate the gear change. The Dingle (the word is a combo of 'dual' and 'single') works great in hilly terrain both on or off-road. Like our cassette and track cogs, these are made from machined, heat-treated and chrome plated SCM415 CroMoly steel, so they are tough and long lasting.

Dingle cogs thread onto any standard ISO threaded (1.375" x 24tpi) fixed-gear hub, and like all fixed-gear cogs require the use of a lockring. In order to keep them narrow enough to work with standard fixed-gear thread width, Dingle cogs are compatible with 9-speed chains only.

**Available sizes:**

17/19t, 17/20t, 17/21t



## CASSETTE COGS

Our cassette-type cogs are designed to fit on standard Shimano-compatible freehub bodies. These cogs have a tall tooth profile that is essential for preventing chain skip from the extra torque a singlespeed drivetrain encounters. In addition to being a stellar SS cog, the cog base width (where it contacts the freehub body) is 4.35mm, so you can stack a few of them up and use a 9-speed shifter for a simplified multi-speed drivetrain. This width also prevents it from ruining the freehub body as a result of digging grooves into it like skinny stamped cogs have a tendency to do. Surly cogs are machined from SCM415 CroMoly steel, then heat-treated for toughness and chrome-plated for surface hardening and enhanced chain lubricity. Our cogs will work with 6- to 9-speed 3/32" chains, although we recommend the inherently updated quality of an 8- or 9-speed chain. They are available in every increment from 13-22t, so you can select that perfect gear.



## TRACK COGS

Our track cogs are designed to spin onto standard ISO-threaded (1.37" x 24tpi) hubs, so they will work with most English, Italian and Japanese hubs, including the Surly New track hubs. The thread base is 7.4mm wide for maximum thread engagement while maintaining enough room for a track lockring to thread on. Like our cassette-splined cogs, these are made from machined, heat-treated and chrome-plated SCM415 CroMoly steel, so they are tough and long lasting. Track cogs are available in either 3/32 or 1/8" tooth thicknesses and in every size from 13-22t.



## TRACK LOCKRINGS

CNC-machined from premium stainless steel...no flaking chrome or rusting. We've improved the design to increase thread contact. It's now a full 5mm thick, plus a lip (0.65mm extra) to maximize thread contact on all compatible hubs. Fits English lockring threads (1.29" x 24t LH) to work on almost all track hubs available today except Campagnolo (1.32" x 24t LH) and French (33 x 1mm LH).



## KRAMPUS FORK

Designed with our Krampus frame, this fork has clearance for a 3" tire on a 50mm rim. To accommodate such big tires it's got a longer axle-to-crown measurement than our Ogre or Karate Monkey forks. It is a perfect rigid fork option for lots of 29ers out there. The Krampus fork's blades were designed and manufactured specifically to play well with the unique forces such a long fork with big tires will encounter, and the steer tube is standard 1-1/8" threadless. It has line guides for disc brake hose, but no rim brake studs and no bottle cage eyelets.

**Axle-to-crown:** 483mm  
**Rake:** 47mm  
**Steerer:** 260mm  
**Tire Clearance:** 29 x 3"  
**Weight:** 2.5 lb (1.14kg) uncut



## KARATE MONKEY FORK

The Karate Monkey CroMoly fork is for 29" wheels. We've redesigned it, with larger diameter, thinner walled tubes to provide a more supple ride, and now it's disc brake compatible only. Suspension corrected for 80mm travel frames, it sports brake line guides, fender mounting eyelets, and a 51mm IS caliper mount - no rim brake mounts at all. 1-1/8" threadless steerer, tapered straight blades and a black powdercoat finish.

**Axle-to-crown:** 468mm  
**Rake:** 43mm  
**Steerer:** 260mm  
**Tire Clearance:** 29 x 2.5"  
**Weight:** 2.6 lb (1.2kg) uncut



## OGRE FORK

The Ogre fork replaces 80mm suspension forks designed for use on 29" wheeled bikes. Made of 4130 CroMoly, it's got 51mm IS disc mounts, removable canti pivots, brake-line guides, low-blade threaded barrel bosses and mid-blade eyelets for a rack. This fork is designed to run disc brakes, fenders and a rack simultaneously. Two sets of water bottle cage mounts, one on each leg. Each cage may be run in a higher or lower position. Steertube is 1-1/8" threadless steerer. Black powdercoat finish.

**Axle-to-crown:** 468mm  
**Rake:** 43mm  
**Steerer:** 260mm  
**Tire Clearance:** 29 x 2.5"  
**Weight:** 3.1 lb (1.4kg) uncut





## TROLL FORK

The Troll fork is just like the one that comes on our new Troll frame, a 26" wheeled fully geared utility bruiser and cruiser. The Troll fork replaces 100mm travel suspension forks. Like all our forks, it's constructed of CroMoly steel. It sports removable rim brake pivots as well as a 51mm disc caliper mount. Unlike our other forks it's designed to accept a rack while using a disc brake, via through-blade threaded mounts in two places on each fork blade, and it's even got fender eyelets. Check before you order. Steerer is 1-1/8" threadless. Finish is black powdercoat.

**Axle-to-crown:** 453mm  
**Rake:** 40mm  
**Steerer:** 260mm  
**Tire Clearance:** 26 x 2.5"  
**Weight:** 3.1 lb (1.4k)g uncut



## 1X1 FORK

We now have three 1X1 forks available. First, the original: 80mm suspension "corrected," rim brake pivots, fender eyelets and nothing else. Next, the same thing (with rim brake pivots) with a 51mm disc mount and line guides. The third version has the rim brake mounts, the disc caliper mount, and the line guides but it is corrected for frames designed for 100mm suspension forks. All are triple butted and take real big tires...you can stuff 2.7" tires between the blades and have room to spare. All are made from 4130 CroMoly tubing, all have 1-1/8" threadless steerers and all are powdercoated black.

### ALL 1X1 FORKS

**Steerer:** 260mm  
**Tire Clearance:** 26 x 2.7"

### 80mm

**Axle-to-crown:** 413mm  
**Rake:** 45mm  
**Weight, canti only** 2.24 lb (1.01kg) uncut  
**Weight, disc:** 2.34 lb (1.06kg) uncut

### 100mm

**Axle-to-crown:** 453mm  
**Rake:** 40mm  
**Weight:** 2.8 lb (1.3kg) uncut



80mm disc/canti shown

## INSTIGATOR FORK

The Instigator rigid fork replaces 100mm travel suspension forks. It is constructed of thick-walled, single-buttetted 4130 CroMoly, so it will hold up under pressure. It features a 51mm IS disc mount, removable canti pivots, 1-1/8" threadless steerer and a black powdercoat finish. If you want to run fatties in this fork, go ahead. You can easily wedge a 2.7" tire between those straight, tapered (31.8-28.6mm) blades. Tandem and dirt jump rated. How many other forks can say that? One or the other, of course. Not meant for dirt jumping on tandems.

**Axle-to-crown:** 447mm  
**Rake:** 43mm  
**Steerer:** 260mm  
**Tire Clearance:** 26 x 2.7"  
**Weight:** 3.1 lb (1.4kg) uncut



## FAT BIKE FORKS

What with the inclusion of the Moonlander in our lineup, we now offer three forks capable of handling our massive tires. All of our forks share an axle-to-crown measurement of 447mm and a rake of 43mm. All sport 51mm IS disc mounts.

**Axle-to-crown:** 447mm  
**Rake:** 43mm  
**Steertube length:** 260mm  
**Tire Clearance:** Pugsley = 26 x 3.8" (on 82mm rims)  
 Moonlander = 26 x 4.7" (on 100mm rims)

### PUGSLEY

First, the Pugsley 135mm offset. This fork uses a 135mm spaced hub, same as the rear wheel, and has one curved (aka "offset") blade which matches the 17.5mm offset of the Pugsley frame. This means you can swap front and rear wheels if, for example, your freehub body seizes up or won't engage in extreme climates or physical conditions. This fork requires the use of a rear hub and a rear disc brake adapter.

The Pugsley 100mm non-offset fork accepts a regular 100mm spaced front hub and a front disc brake adapter. Due to the relatively narrow fork end spacing, removing and installing the wheel is a bit trickier than on the 135mm spaced fork.

Both the Pugsley 135mm offset and the Pugsley 100mm non-offset have clearance for our 3.8" tires on 82mm rims.



### MOONLANDER

The Moonlander fork has clearance for a 4.7" tire on a 100mm rim. It accepts a 135mm hub, but it is non-offset, so you cannot swap your front and rear wheels.

Unlike the Pugsley 135 fork, the Moonlander fork is designed for use with a front disc brake adapter so that A) You don't have to remember to buy two rear adapters, and B) If your brakes of choice are only available with IS mounts and/or as a pair, you won't have to break up a set and find an additional rear brake. Because of this combination of spacing and disc brake adapter type, the Moonlander fork is not compatible with Paul 135mm Whub. It is compatible, however, with any 135mm rear hub and our 135mm front hub.



## PACER FORK

This is the same lugged and brazed fork that we provide with our Pacer road frameset, now with a new crown and dropouts of our own design. It will allow you to run 28mm tires with fenders or 32mm tires without. Uses standard-reach (47-57mm) calipers. This fork comes with single-eyelet dropouts, 1-1/8" threadless steerer and a black powdercoat finish.

**Axle-to-crown:** 371mm  
**Rake:** 45mm  
**Steerer:** 300mm  
**Tire Clearance:** 700c x 32mm (28mm Surlyfender)  
**Weight:** 2.2 lb (1.0kg) uncut



## LONG HAUL TRUCKER FORK

The Long Haul Trucker fork is designed to mount racks and fenders and to haul stuff. Offered in 26" and 700c wheel sizes, the fork's new crown provides ample clearance for 26 x 2.1" or 700 x 45mm tires, and sports threaded eyelets in four locations (dual dropout, mid-blade and fork crown) to provide more options for mounting stuff, from racks to whatever. Options galore. Now available in rim brake or disc versions, in both 26" and 700c wheel sizes. The disc fork has a mounting plate for standard 51mm calipers. Curved blades, CroMoly steel. 1-1/8" threadless steer tube, black powdercoat finish.

Options: Disc (26" and 700c) or Rim Brake (26" and 700c)

**Axle-to-crown:** 26" = 376mm  
 700c = 390mm  
**Rake:** 45mm  
**Steerer:** 26" (42-54cm frames) = 300mm  
 26" (56-62cm frames) = 400mm  
 700c (56-64cm frames) = 350mm  
**Tire Clearance:** 26 x 2.1" or 700c x 45mm  
**Weight:** 26" = 2.1 lb (0.97kg) (rim brake version) uncut  
 700c = 2.3 lb (1.0kg) (rim brake version) uncut



## STEAMROLLER FORK

Our Steamroller fork, designed around our fixed-gear frame, is brazed with a flat crown that is drilled to accept a standard-reach (47-57mm) caliper brake. It has clearance for 700c x 38mm tires. There are no eyelets at the dropouts. Available with 1 or 1-1/8" threadless steerer.

**Axle-to-crown:** 1" = 368mm  
 1-1/8" = 375mm  
**Rake:** 38mm  
**Steerer:** 300mm  
**Tire Clearance:** 700c x 38mm  
**Weight:** 1" = 1.9 lb (0.9kg) uncut  
 1-1/8" = 2.2 lb (1.0kg) uncut



## BIG DUMMY FORK

We designed the Big Dummy fork to handle the rigors of hauling you and your precious cargo. Its tapered 4130 CroMoly straight blades provide the durability needed for a cargo bike without delivering a jackhammer ride. The Big Dummy fork features 51mm IS disc mounts, removable canti pivots, 1-1/8" threadless steerer, disc brake line/housing guides, single dropout eyelets, 80mm suspension-corrected and a black powdercoat finish.

**Axle-to-crown:** 425mm  
**Rake:** 43mm  
**Steerer:** 260mm  
**Tire Clearance:** 26 x 2.5"  
**Weight:** 2.9 lb (1.3g) uncut



## CROSS-CHECK FORK

Our lugged and brazed Cross-Check fork has room for 700c x 45mm tires and fenders. It's made from 4130 CroMoly steel and features fender eyelets at the dropouts, cantilever brake pivots, and now has through-leg mid-blade eyelets for mounting a rack. The eyelets are threaded 5 x 1mm and located 165mm up from the axle. We offer it in 1 and 1-1/8" threadless steertube versions. Finish is black powdercoat.

**Axle-to-crown:** 400mm  
**Rake:** 44mm  
**Steerer:** 300mm  
**Tire Clearance:** 700c x 45mm  
**Weight:** 1" = 2.1 lb (0.97kg) uncut  
 1-1/8" = 2.3 lb (1.0kg) uncut



## 1X1 TORSION BAR

Stout, wide, and made of 4130 CroMoly steel, the Torsion Bar has a 15° bend and no rise. It's 666mm wide. We've offered the Torsion Bar for many years because people like it. It's durable, stiff and nice and wide for comfort and control. Available in silver or black finish.

**Color:** Silver or Black

**Clamp:** 25.4mm



## THE OPEN BAR

The Open Bar is an upright bar but not an uptight bar. It's equally suited to cruising, commuting, and even some singletrack, though it should be noted that this is not by any means a DH bar. We left it a bit flexy to take some of the harsh out of your ride. The angle makes it comfy for your wrists. The width enables loads of control. It's got plenty of room for grips, shifters and brake levers. Knurled clamp area. 4130 CroMoly steel. Available in low rise and no rise versions.

**Color:** E.D. coated, Black

**Clamp:** 25.4mm

**Width:** 666mm

**Angle:** 53°

**Rise:** 0 or 40mm



## MOLOKO BAR

The Moloko bar is milk, plus. It is, essentially, our Open bar with a crossmember welded in. It's a bit sturdier and offers a good place to mount lights, computers, gadgets, whirlygigs, and whatever other effluvium you need. And by golly, it's CroMoly. 666mm wide. Available in low rise and no rise versions.

**Color:** Black

**Clamp:** 25.4mm



## SURLY RACK

Surly Racks are well-thought-out, durable, expedition-worthy racks that work with most panniers. While our racks aren't limited solely to heavy duty touring, that is what they were designed for.

Repairability should be a consideration for any product that will be used in every extreme, which is why the main body of our Racks is made of tubular CroMoly steel. In the rare instance that the Rack breaks, you should be able to find, even in the most remote regions of planet Earth, somebody to TIG, MIG, stick-weld, braze or solder a Surly Rack back together. An aluminum rack won't afford you the same luxury. The Racks' hardware is stainless steel.

Our height-adjustable front Rack is a lowrider/highrider design. Panniers mounted in the lowrider position provide a more stable ride, but can be a burden when riding rocky or rutted roads and trails. The upper rails provide an alternate pannier mounting position for these types of conditions. The platform above the wheel provides extra space to lash on more stuff. The front Rack mounts directly to forks equipped with a mid-blade eyelet, located approximately 165mm from the dropout eyelet. This is a standard eyelet location found on many touring-specific forks, including our Long Haul Trucker fork. We also provide hardware to securely mount a Surly Rack on forks that do not have a mid-blade eyelet...which means you can mount it on almost any rigid fork, providing there is nothing in the way.

The rear Rack is also height-adjustable, enabling it to fit a wide variety of wheel sizes while allowing you to move its center of gravity as low as possible for a more stable ride. Its wide platform has plenty of room for rack trunks, sleeping bags, tents, boxes of lima beans, or small cages full of hamsters. The stainless steel hardware we provide will enable you to fit them to most rigid 26" and 700c frames, and to forks equipped with drum, caliper or cantilever brakes. Disc brakes and suspension are generally not compatible with our rear Racks, though there is an increasing number of frames designed to allow the use of racks and disc brakes, such as our Troll.



Rear Rack



Front Rack

## RACK PARTS

We now offer small parts kits for your Surly Rack. In the past if you lost or damaged one of the bits of hardware for your Surly Rack you would have to either buy a whole new hardware kit or hope that your story caught one of us on a good day and we'd send you out the small part for free. That was expensive and inconvenient for everyone involved. We still offer complete hardware kits, but now offer smaller kits too so you can order the parts you need at a significant discount from the big kits.

### AVAILABLE KITS INCLUDE:

#### Front:

Complete Hardware kit (front or rear)  
Mid-blade adapter kit  
Flat sliding plate kit  
Offset sliding plate kit

#### Rear:

Rear tube block kit  
Standard length upper tube kit  
Extra long upper tube kit (240mm)  
Lower tube kit  
All lower hardware and tube kit  
All upper hardware and tube kit

## CONSTRUCTOR SEATPOST CLAMP

The Constrictor was designed specifically to end slipping seatposts. The extra-thick clamp utilizes an 8mm stainless bolt and accommodates a rear cantilever brake hanger, if you decide to go that route. The Constrictor is machined out of aluminum billet and black anodized. It's available in 30.0 and 31.8mm sizes.



## CONSTRUCTOR STEEL SEATPOST CLAMP

Rated fully KICKASS by the U. S. Department of Wicked Shit, our cast and polished stainless steel clamps won't rust or chip paint because they can't (even the black ones!). They're shiny! They look good! And most importantly, they deliver the clampability seatposts crave. 30.0 and 31.8mm sizes.

**Color:** Silver or Black



## 1X1 SINGLEATOR

Midwest singlespeed legend Pete Geigle developed the 1x1 Singleator so you singlespeed virgins could taste the pure mountain biking experience without spending too much cash. Installing horizontal dropouts on your frame can be difficult and/or expensive, particularly if your steel is of the aluminum variety. The Singleator mounts right up to your derailleur hanger and provides a simple, effective and adjustable means of tensioning the excess chain slack found in vertical dropout singlespeed drivetrains.

The Singleator features a triple-sealed spring, large cog capacity, chain guides, fully-adjustable chainline, floating pulley, and a stainless steel pivot bushing. The main body is forged, not machined so it's strong. We've gone with an 11-tooth pulley for smooth, quiet operation. And it now works with both 1/8" (BMX) and 3/32" (geared bikes) chains. Beware impostors; the Singleator is the granddaddy and outperforms all others.

**Color:** Black or Silver



## SINGLEATOR TOOL

The production of our stainless steel chainrings generates a lot of scrap material, so we decided to use some of it to make the Singleator Tool. This polished and laser-etched tool sports an 18mm open-end wrench on one end (for adjusting the tension on a Singleator), and a bottle opener on the other end. It's compact (because you don't need to put a lot of tension on a Singleator spring), so it easily fits in a tool kit, in a pocket or on a key chain.



## TUGGNUT CHAIN TENSIONER

Ever stomp on the pedals just to have your rear wheel slide forward in the dropouts and throw your chain? We have...using all kinds of hubs in all kinds of frames. There are lots of BMX-style tensioners out there, but few of them fit in our dropouts without some serious grinding. So, we decided to design a chain tensioner that will keep that rear wheel static in our dropouts...and most other kinds of rear-facing horizontal dropouts. Plus, ours will open up a bottle o' brew. The body of the Tuggnut is investment cast in stainless steel for durability. It features a winged bolt for tool-free adjustments, and two axle holes for a wide range of fore/aft wheel positions. The Tuggnut comes with an aluminum adapter that reduces the axle hole from 10-6mm, so you can use it with quick-release axles, in addition to nutted axles. We sell it as a single, because you really only need one...on the drive side. But if you absolutely need one on the non-drive side of your rig to achieve balance in your life you are in luck...the bottle opener works either way.



## SINGLESPEED SPACER KIT

Got a rear wheel from a geared bike collecting dust in your garage? Maybe it's time you gave it some new life as a singlespeed wheel. We now offer a singlespeed spacer kit that allows you to use singlespeed cassette cogs on the freehub body of your multi-speed Shimano cassette-compatible hub.

With the supplied selection of anodized aluminum spacers, you can attain a perfect chainline to complement your road, track or mountain crankset. Our large-diameter stainless steel cassette lockring holds everything together and perfectly matches the outside diameter of the spacers. Plus, it matches the machined shoulder of our singlespeed cassette cogs (not included). The lockring is machined to utilize a common Shimano cassette lockring tool for installation and removal. This isn't just a mix of off-the-shelf parts; we went the extra distance to give you a kit that will provide maximum functionality, durability and aesthetic value.



## STAINLESS STEEL CABLE HANGER

We couldn't find a cable hanger we liked which also fit our Constrictor seatpost clamp's oversized bolt. So we made one. Long enough to eliminate kinked rear brake cables, large enough to fit over thick post clamp bolts, versatile enough to work with most other post clamps, and it's even got an adjusting barrel.



## JETHRO TULE

Our Jethro Tule combines a bottle opener and an offset box wrench for your opening needs and tightening pleasure. The double sided 15mm box wrench works with most nutted hubs out there, and fits nicely inside recessed dropouts like those found on many of our own frames, such as the Steamroller and Karate Monkey. The Tule's spoon shaped handle is designed to fit comfortably in your palm, and its left feels good in your pocket.



## JUNK STRAP

Our Junk Straps are basically really long toe straps. They're 120cm of woven nylon with a stainless steel buckle. We had them made to our specifications to ensure that they work well and last a long time. They're easy to use and they stay tight. Once you're ready, loosening them is quick and easy. They're light, pack small, and securely and conveniently attach all kinds of stuff to your rack, basket, handlebar, backpack, under your seat, around your thigh...just about anyplace. Use them to secure small dogs to your child. If your buddy breaks his leg, you can use a few to hold a splint in place while you drag him out of the woods. Wear one as a stylish belt (if your waist is smaller than 120cm). You can combine them for even longer straps. Available singly with a header card and in 6-packs with no header.



## SURLY HIP FLASK

Hey mang! I'm Flasky! You know, where ever I go people are always saying to me "Flasky, you're a good friend. You keep me warm when I'm cold, loose when I'm tight, and twirling when I should be sleeping." Hey, I try! But I want people to know how tough I am! Not even a dog can hurt me! Well maybe a dog could, I don't know, like if it was maybe a pit-bull or something. Especially an alcoholic pit-bull who hadn't had a drink in a while. But still, I'm pretty tough cuz I'm stainless steel. I don't rust and I don't trap flavors like plastic. That way your gin don't taste like your juice. I'm a good size too; more than enough but never too much, except sometimes. So yeah, that's me. Let's go for a ride. Right now. C'mon, don't be stuck up.

**Stainless steel. 6 oz (177ml)**



## FRAME DECALS

Complete decal sets are available for each frame we sell. Decals are dry transfer style. Each decal set includes a headbadge.



## JERSEY

So. Our jerseys are new this year. Not in that we haven't offered jerseys before...we have for many years. Rather, these are a new design with new fabric, from a new manufacturer. They really are new and improved. Mens and womens' long and short sleeve. Nice, soft Merino wool. Hand wash cold, lay flat and air dry. Call or write us or contact your local bike shop to find out what colors we're offering, because they change from time to time.



## WOOL FULL ZIP HOODIE

Everyone likes hoodies. We do too. Our latest hoodie is mostly wool because wool has a lot of technical features we like a lot...it insulates better than cotton, both warm and cold, and it tends to last longer too. Others have done wool hoodies but almost always made them fit like a piece of technical clothing. Ours is not cut tight, they are not riding-specific. They will fit over other clothes. It's got a full length high quality metal zipper you can regulate temperature with a zipper. It'll work equally well whether you're riding your bike or lounging in a lawn chair in your mohair trimmed cut-offs and flipflops. Wool resists stink build-up, which also means you won't have to wash it as often as regular cotton sweatshirts. When you do wash it, we recommend hand washing in cold water and air drying. This will increase its lifespan and reduce any chance of it shrinking. It is made of 80% Merino wool for soft niceness and 20% nylon to make it more durable.



## T-SHIRTS

Oh yeah, we've got T-shirts. T-shirts let others know that you have a reason to wear clothes, that you support various ideas or entities, or at least that you choose to comment on life's vast cornucopia of experience and grandeur, although there is an off-chance that for one reason or another you just don't care what you wear. Well you're all welcome here, you sons and daughters of life's bounty, you grains of sand on the shores of the cosmic yelp. We've got you covered. We offer more designs than you see here, some in men's fit, others in ladies cut, some long sleeve, others short, even one in ¾ sleeve. What a world. **Check out [surlybikes.com](http://surlybikes.com) to see the latest shirts.**



### LOGO TEE

It's not just a name, it's a whole personality type. Shirts are black. Short or long sleeve. Just the logo on the front.

**Sizes:** S-XXL



### KARATE MONKEY T

Black. Short and long sleeve. Small logo on the left boob. The Karate Monkey his-self on the back.

**Sizes:** M-XXL



### RAGLAN

Two tone: black and off black. Logo on the front. Long sleeves, men's and women's cut. 'Nuff said.

**Sizes:** M-XXL

## HATS



### CYCLING CAP

Our caps are made in the U.S. by Walz Caps of 100% wool fabric because wool works well for moisture, temperature and odor control. They come in two sizes to fit a wide range of melons.

**Color:** Black

**Sizes:** S/M or L/XL



### TRUCKER HAT

Technically it's a Trucker Hat, in that it's got a mesh back and plastic size adjustment band. But it fits more like a ball cap. Passive-aggressive logo patch suitable for artsy fartsy statement on its own, or write in your own message.

**Color:** Black w/orange patch

**Sizes:** One size fits many. Won't fit watermelon heads

## PATCHES



### SMALL DEER

**Color:** Black & orange



### RECTANGLE DEER

**Color:** Black & orange



### SURLY

**Color:** Black & white

**Sizes:** 4, 6 & 10"

## SOX

As you must know by now, wool resists odor. We have found that is a good feature in a sock. They also wick and insulate better than cotton or all synthetic, so you can wear them comfortably in a pretty wide range of climates. Surly socks are made by DeFeet. They are Merino wool, with a small percentage of synthetic for increased durability. We offer many designs in a 5" height and a few knee-high models, check the website for availability, cuz we like to mix things up and keep you on your toes. The tall socks are thicker than the others and play well with knickers (as we call them here in the U.S. Yes, we know it means ladies' underwear in the UK).

Each design comes in four sizes so pretty much everyone should find one that fits.



### TALL



### RACING STRIPE



### DUB-L STRIPE



### BLOCKHEAD



### LOGO

## JUNK RAG

Put your junk in a rag. Blow your nose. Tourniquet gushing wounds. Wash your face. Look all Ralph Macchio-doing-aerobics. Others call them hankerchiefs or doo rags. Ours are all cotton.



Size	Euro	US Men's	US Women's
S	36-39.5	—	6-8
M	40-42.5	7-9	8.5-10.5
L	43-45.5	9.5-11.5	11-13
XL	46+	12+	—

# KRAMPUS FRAME

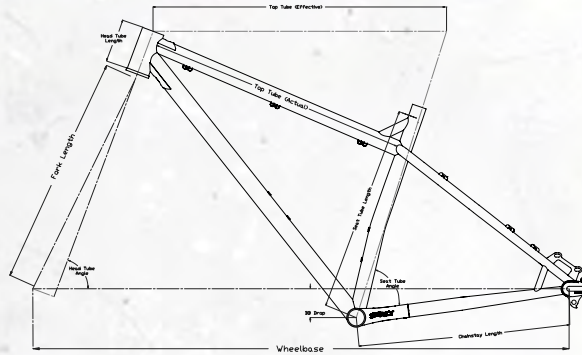

## FRAME GEOMETRY

Size	ST (C-T)		TT (C-C)*		TT (Effective)		HT Angle	ST Angle	BB Drop		CS Length	
	inches	mm	inches	mm	inches	mm	degrees	degrees	inches	mm	inches	mm
<b>Small</b>	14.7	375.0	22.5	561.0	23.0	585.0	69.5	72.5	2.4	60.0	17.6	446.0
<b>Medium</b>	16.7	425.0	22.8	578.0	24.0	609.0	69.5	72.5	2.4	60.0	17.6	446.0
<b>Large</b>	18.7	475.0	23.5	597.4	24.8	630.0	69.5	72.5	2.4	60.0	17.6	446.0
<b>xLarge</b>	20.7	525.0	24.2	614.7	25.4	645.0	69.5	72.5	2.4	60.0	17.6	446.0

Size	Wheel Base		S.O. Height**		HT Length		FK Length		FK Rake	
	inches	mm	inches	mm	inches	mm	inches	mm	inches	mm
<b>Small</b>	46.9	1190.0	30.4	773.4	3.5	90.0	19.0	483.0	1.9	47.0
<b>Medium</b>	43.9	1114.0	31.5	799.7	3.7	95.0	19.0	483.0	1.9	47.0
<b>Large</b>	44.7	1135.0	32.5	825.8	3.9	100.0	19.0	483.0	1.9	47.0
<b>xLarge</b>	45.3	1151.0	33.7	856.6	4.5	115.0	19.0	483.0	1.9	47.0

\* All dimensions are preliminary and are subject to change.  
 \*\*Standover height measured using Surly Knard tire measuring 30.5" in diameter.

## FRAME SPECIFICATIONS

- Tubing:** Surly 4130 CroMoly steel. Main Triangle TIG-welded, custom butted. Sweet CS Yoke.
- Rear dropouts:** Horizontal slotted w/derailleur hanger, 135mm O.L.D.
- Brake compatibility:** 51mm IS disc mounts frame and fork.
- Max Disc Brake Rotor Size:** 203mm
- Braze-ons:** Dual water bottle mounts, Surly Trip Guide full line guides for brake and derailleurs, fender and rack eyelets
- Seatpost diameter:** 27.2mm
- Seatpost clamp:** 30.0mm (Surly stainless included)
- Headset/Steertube:** 44mm ID. Recommend EC44 lower cups. Zero Stack on top is o.k.
- Front derailleur compatibility:** High direct mount standard, clamp adapter included
- Bottom bracket shell:** 73mm shell width, threaded standard English (1.37" x 24t)
- Chainring clearance:** Triple 22/34/44t, Double 26/39t, Max single ring clearance, Middle position, 34T. Outer position 44T. (Triple will not work with Surly 50mm rim and 29 x 3" tire)
- Tire clearance:** 29 x 3"
- Fork:** TIG-welded custom butted 4130 CroMoly, 120mm suspension corrected, 1-1/8" steerer tube, 203mm disc brake clearance
- Color:** Moonlit Swamp

# KRAMPUS COMPLETE BIKE

## COMPONENT SIZING

Size	Stem Length		Stem Angle	Handlebar Width		Crank Length
	inches	mm	degrees	inches	mm	mm
<b>Small</b>	2.4	60	7	28.3	720	170
<b>Medium</b>	2.8	70	7	30.7	780	175
<b>Large</b>	3.1	80	7	30.7	780	175
<b>xLarge</b>	3.5	90	7	30.7	780	175

## BIKE SPECIFICATIONS

Component	Type	Description
Headset	Cane Creek	40 series for 44mm
Crankset & BB	Shimano SLX	170 on Small, 175
Brakes	Avid BB7	180/160 HS rotors
Brake Levers	Avid BB5	black
Rims	Surly Rabbit Hole	700 x 50mm w/holes
Front Hub	Surly Ultra Disc	32h black disc
Rear Hub	Shimano 529	32h black disc
Tires	Surly Knard 29 x 3	27tpi
Shifters	Shimano SLX	10-speed RH
Front Derailleur	none	yep
Rear Derailleur	Shimano SLX	10-speed Shadow+
Cog or Cogset	SRAM PC 1050	10-speed 11/36
Stem	Kalloy 31.8	60/70/80/90mm length
Handlebar	Salsa Wammy	0° rise, 780mm width
Saddle	Velo	
Seatpost	Kalloy	
Chain	KMC x10	
Extras	Chain guide	Surly stainless steel post clamp. 14g DT Swiss spokes

Fork steer tubes are uncut. Pedals not included. Specifications sometimes change. Cope.

# KARATE MONKEY FRAME

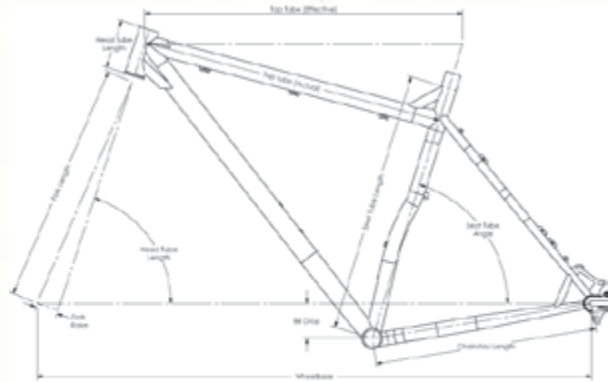

## FRAME GEOMETRY

Size	ST (C-T)		TT(C-C)*		TT (Effective)		HT Angle		ST Angle		BB Drop		CS Length	
	inches	mm	inches	mm	inches	mm	degrees	degrees	inches	mm	inches	mm	inches	mm
<b>Small</b>	16.0	406.4	22.0	557.7	22.7	575.6	71.0	73.0	2.7	68.0	17.0	431.0		
<b>Medium</b>	18.0	457.2	22.6	575.0	23.6	599.3	71.5	73.0	2.7	68.0	17.0	431.0		
<b>Large</b>	20.0	508.0	23.2	589.9	24.3	616.3	72.0	73.0	2.7	68.0	17.0	431.0		
<b>xLarge</b>	22.0	558.8	23.9	607.1	24.9	632.2	72.0	73.0	2.7	68.0	17.0	431.0		

Size	Wheel Base		S.O. Height**		HT Length		FK Length		FK Rake	
	inches	mm	inches	mm	inches	mm	inches	mm	inches	mm
<b>Small</b>	41.2	1046.1	30.0	762.9	3.5	90.0	18.4	468.0	1.7	43.0
<b>Medium</b>	41.9	1064.9	31.2	792.7	3.9	100.0	18.4	468.0	1.7	43.0
<b>Large</b>	42.4	1076.8	32.4	822.5	4.3	110.0	18.4	468.0	1.7	43.0
<b>xLarge</b>	43.0	1093.0	33.6	853.5	4.9	125.0	18.4	468.0	1.7	43.0

\* All dimensions are preliminary and are subject to change.  
 \*\*Measurements use tire with a diameter of 676mm (Tioga 2.1" DH), taken from middle of the toptube to level ground.

## FRAME SPECIFICATIONS

- Tubing:** Surly 4130 CroMoly steel. Main triangle double-buttet. TIG-welded
- Rear dropouts:** Surly horizontal dropouts with derailleur hanger, 135mm O.L.D.
- Brake compatibility:** 51mm IS disc mounts front and rear
- Braze-ons:** Dual water bottle mounts, Surly Trip Guides for continuous brake and derailleur housing
- Seatpost diameter:** 27.2mm
- Seatpost clamp:** 30.0mm (Surly stainless included)
- Headset/Steertube:** 1-1/8" threadless
- Front derailleur clamp:** 28.6mm (top pull)
- Bottom bracket shell:** 73mm wide, standard English threading (1.37" x 24t)
- Chainring clearance:** 48t max
- Tire clearance:** 29 x 2.55" knobbies. Individual tire and rim combos affect tire clearance
- Fork:** Suspension-corrected (80mm), tapered straight blade, 4130 CroMoly. 51mm IS disc mount
- Color:** Saftey Scissors Blue or Stretchpants Black

# KARATE MONKEY COMPLETE BIKE

## COMPONENT SIZING

Size	Stem Length		Stem Angle	Handlebar Width		Crank Length
	inches	mm	degrees	inches	mm	mm
<b>Small</b>	3.5	90.0	7.0	26.0	660.0	170.0
<b>Medium</b>	3.9	100.0	7.0	26.0	660.0	175.0
<b>Large</b>	4.3	110.0	7.0	26.0	660.0	175.0
<b>xLarge</b>	4.7	120.0	7.0	26.0	660.0	175.0

## BIKE SPECIFICATIONS

Component	Type	Description
Headset	Cane Creek 40	1-1/8" threadless. Black
Crankset & BB	TruVativ FireX 1.1	33t ring w/ring guard. Forged. Black
Brakes	Avid BB7	Cable actuated. 160mm rotors front & rear
Brake Levers	Avid FR-5	Black
Rims	WTB Speed Disc 29	32h. Black. Machined sidewalls
Hubs	Surly New model	32h. Black. Machined sidewalls
Tires	WTB Exiwolf DNA	29 x 2.3". Steel bead. Black
Cog or Cogset	Shimano singlespeed freewheel	17t. 3/32"
Stem	Kalloy AS-008	25.4mm bar clamp. Aluminum. 4-bolt face. Black
Handlebar	Salsa Moto Ace	660mm width. 17° bend. Black
Saddle	Velo VL-2155	Steel rails. Black vinyl. Feels pretty o.k.
Seatpost	Kalloy SP-342	27.2mm. 350mm. Black
Chain	KMC X8	
Extras		Surly stainless steel post clamp. 14g DT Swiss spokes

Fork steer tubes are uncut. Pedals not included. Specifications sometimes change. Cope.



# OGRE FRAME

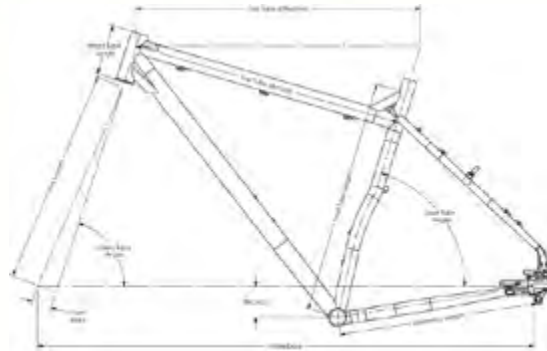

## FRAME GEOMETRY

Size	ST (C-T)		TT (C-C)*		TT (Effective)		HT Angle degrees	ST Angle degrees	BB Drop		CS Length	
	inches	mm	inches	mm	inches	mm			inches	mm	inches	mm
<b>Small</b>	16.0	406.4	22.0	557.7	22.7	575.6	71.0°	73.0	2.7	68.0	17.0	431.0
<b>Medium</b>	18.0	457.2	22.6	575.0	23.6	599.3	71.5°	73.0	2.7	68.0	17.0	431.0
<b>Large</b>	20.0	508.0	23.2	589.9	24.3	616.3	72.0°	73.0	2.7	68.0	17.0	431.0
<b>xLarge</b>	22.0	558.8	23.9	607.1	24.9	632.2	72.0°	73.0	2.7	68.0	17.0	431.0
<b>xxLarge</b>	24.0	609.6	24.7	627.1	25.5	648.1	72.0°	73.0	2.7	68.0	17.0	431.0

Size	Wheel Base		S.O. Height**		HT Length		FK Length		FK Rake	
	inches	mm	inches	mm	inches	mm	inches	mm	inches	mm
<b>Small</b>	41.2	1046.1	30.0	762.9	3.5	90.0	18.4	468.0	1.7	43.0
<b>Medium</b>	41.9	1064.9	31.2	792.7	3.9	100.0	18.4	468.0	1.7	43.0
<b>Large</b>	42.4	1076.8	32.4	822.5	4.3	110.0	18.4	468.0	1.7	43.0
<b>xLarge</b>	43.0	1093.0	33.6	853.5	4.9	125.0	18.4	468.0	1.7	43.0
<b>xxLarge</b>	43.7	1109.2	34.8	884.4	5.5	140.0	18.4	468.0	1.7	43.0

\* All dimensions are preliminary and are subject to change.  
 \*\*Measurements use tire with a diameter of 740mm (29 x 2.3"), taken from middle of the toptube to level ground.

## FRAME SPECIFICATIONS

- Tubing:** Surly 4130 CroMoly steel. Main triangle double-buttet. TIG welded
- Rear dropouts:** Horizontal slotted with derailleur hanger, 135mm O.L.D. Features Rohloff torque arm slot and threaded eyelets for fenders, racks and Surly trailer mounts
- Brake compatibility:** Disc and rim brake compatible. Disc mounts are 51mm IS Rim brake pivots are removable. Note: rear disc brake is limited to 160mm maximum rotor diameter and requires the use of Surly caliper adapter
- Braze-ons:** Full-length Surly Trip Guide housing line guides for derailleurs and brakes; three sets of bottle cage mounts (one set may be run in higher or lower position); removable post cantilever pivots; upper seatstay threaded barrels, mid- and low-blade fully threaded through-blade fork eyelets; threaded holes for racks, fenders and trailer mounting nuts; Rohloff OEM2 axle plate mounting slot
- Seatpost diameter:** 27.2mm
- Seatpost clamp:** 30.0mm (Surly stainless included)
- Headset/Steertube:** 1-1/8" threadless
- Front derailleur clamp:** 28.6mm, top pull
- Bottom bracket shell:** 73mm shell width, threaded standard English (1.37" x 24t)
- Chainring clearance:** 26/36/46t
- Tire clearance:** 29 x 2.5". Individual tire and rim combos affect tire clearance
- Fork:** TIG-welded 4130 CroMoly, 80mm suspension corrected, tapered straight blade. Low- and mid-blade fully threaded through-blade rack eyelets; fender mount eyelets at dropout; 1-1/8" x 260mm threadless steer tube, 51mm disc mount (203mm max. rotor diameter), removable cantilever pivots, line/housing guides; two sets of bottle cage mounts, each height adjustable (note: cages cannot be used on fork with some racks, and vice versa)
- Color:** Army Green or Blacktacular

# OGRE COMPLETE BIKE

## COMPONENT SIZING

Size	Stem Length		Stem Angle degrees	Handlebar Width		Crank Length mm
	inches	mm		inches	mm	
<b>Small</b>	3.5	90.0	7.0	26.0	660.0	170.0
<b>Medium</b>	3.9	100.0	7.0	26.0	660.0	175.0
<b>Large</b>	4.3	110.0	7.0	26.0	660.0	175.0
<b>xLarge</b>	4.7	120.0	7.0	26.0	660.0	175.0
<b>xxLarge</b>	5.1	130.0	7.0	26.0	660.0	175.0

## BIKE SPECIFICATIONS

Component	Type	Description
Headset	Cane Creek 40	1-1/8" threadless. Black
Crankset & BB	TruVativ Firex 3.1	22/32/44t. Black
Brakes	Avid BB7	Cable actuated. 160mm rotors front & rear
Brake Levers	Avid FR-5	Black
Rims	Alex Adventurer	700c. 32-hole. Black w/machined sidewalls
Hubs	Shimano Deore Disc	Model M529. 32h. QR. Black
Tires	WTB Exiwolf	29 x 2.3". Steel bead
Shifters	Shimano Deore	3 x 9 Rapidfire
Front Derailleur	Shimano Deore	Model 590. 28.6mm. Top pull
Rear Derailleur	Shimano Deore	Model 590SGS. 9-speed
Cog or Cogset	Shimano HG-61	11-13-15-17-20-23-26-30-34t
Stem	Kalloy AS-008	25.4mm bar clamp. Aluminum. 4-bolt face. Black
Handlebar	Salsa MotoAce	17° bend. Black
Saddle	WTB SST Comp	Steel rails. Black vinyl. Feels pretty o.k.
Seatpost	Kalloy SP-342	27.2mm. 350mm. Black
Chain	SRAM PC-971	Silver
Extras		Surly stainless steel post clamp. 14g DT Swiss spokes

Fork steer tubes are uncut. Pedals not included. Specifications sometimes change. Cope.



# TROLL FRAME

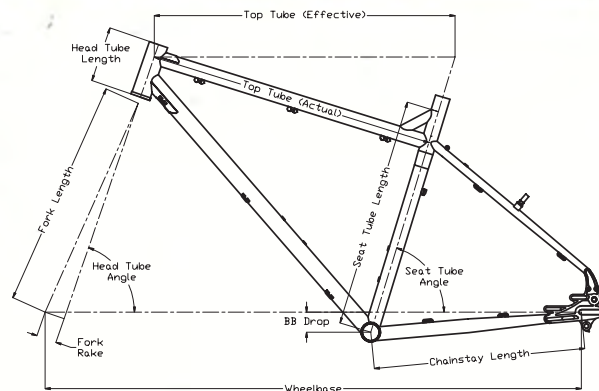

## FRAME GEOMETRY

Size	ST (C-T)		TT (C-C)*		TT (Effective)		HT Angle	ST Angle	BB Drop		CS Length	
	inches	mm	inches	mm	inches	mm	degrees	degrees	inches	mm	inches	mm
<b>xSmall</b>	14.0	355.6	20.9	532.0	21.5	546.0	71.0	73.0	1.6	40.0	16.5	419.0
<b>Small</b>	16.0	406.4	21.6	549.0	22.5	571.0	71.0	73.0	1.6	40.0	16.5	419.0
<b>Medium</b>	18.0	457.5	22.4	570.0	23.5	596.0	71.0	73.0	1.6	40.0	16.5	419.0
<b>Large</b>	20.0	508.8	23.2	590.0	24.3	616.0	71.0	73.0	1.6	40.0	16.5	419.0
<b>xLarge</b>	22.0	558.8	23.9	608.3	24.8	631.0	71.0	73.0	1.6	40.0	16.5	419.0

Size	Wheel Base		S.O. Height**		HT Length		FK Length		FK Rake	
	inches	mm	inches	mm	inches	mm	inches	mm	inches	mm
<b>xSmall</b>	39.8	1011.9	28.2	717.0	3.5	90.0	17.8	453.0	1.6	40.0
<b>Small</b>	40.8	1037.3	29.3	745.0	3.9	100.0	17.8	453.0	1.6	40.0
<b>Medium</b>	41.8	1062.6	30.5	774.0	4.3	110.0	17.8	453.0	1.6	40.0
<b>Large</b>	42.6	1083.2	31.7	804.0	4.9	125.0	17.8	453.0	1.6	40.0
<b>xLarge</b>	43.3	1098.8	33.0	838.0	5.7	145.0	17.8	453.0	1.6	40.0

\* All dimensions are preliminary and are subject to change.  
 \*\*Measurements use tire with a diameter of 676mm taken from middle of the toptube to level ground.

## FRAME SPECIFICATIONS

- Tubing:** Surly 4130 CroMoly steel. TIG-welded. Main triangle double-butted
- Rear dropouts:** Horizontal slotted with derailleur hanger, 135mm O.L.D. Features Rohloff torque arm slot and threaded eyelets for fenders, racks and Surly trailer mounts
- Brake compatibility:** Disc and rim brake compatible. Disc mounts are 51mm IS Rim brake pivots are removable. Note: rear disc brake is limited to 160mm maximum rotor diameter and requires the use of Surly caliper adapter (included with frames and bikes)
- Braze-ons:** Full-length Surly Trip Guide housing line guides for derailleurs and brakes; two sets of bottle cage mounts; removable post cantilever pivots; upper seatstay threaded barrels, mid-and low-blade fully threaded through-blade fork eyelets; threaded holes for racks, fenders and trailer mounting nuts; Rohloff OEM2 axle plate mounting slot
- Seatpost diameter:** 27.2mm
- Seatpost clamp:** 30.0mm (Surly stainless included)
- Headset/Steertube:** 1-1/8" threadless
- Front derailleur clamp:** 28.6mm, top pull
- Bottom bracket shell:** 73mm shell width, threaded standard English (1.37" x 24t)
- Chainring clearance:** 24/36/48t
- Tire clearance:** 26 x 2.6". Individual tire and rim combos affect tire clearance
- Fork:** TIG-welded 4130 CroMoly, 100mm suspension corrected, tapered straight blade. Low- and mid-blade fully threaded through-blade rack eyelets; fender mount eyelets at dropout; 1-1/8" x 260mm threadless steer tube, 51mm disc mount (203mm max. rotor diameter), removable cantilever pivots, two sets of bottle mounts on each fork blade. Note: you can't always mount bottles on the fork with every rack.
- Color:** Egg Plant and Not So Dark Black

# TROLL COMPLETE BIKE

## COMPONENT SIZING

Size	Stem Length		Stem Angle degrees	Handlebar Width		Crank Length mm
	inches	mm		inches	mm	
<b>xSmall</b>	3.9	100.0	7.0	26.0	660.0	170.0
<b>Small</b>	3.9	100.0	7.0	26.0	660.0	170.0
<b>Medium</b>	4.3	110.0	7.0	26.0	660.0	175.0
<b>Large</b>	4.7	120.0	7.0	26.0	660.0	175.0
<b>xLarge</b>	5.1	130.0	7.0	26.0	660.0	175.0

## BIKE SPECIFICATIONS

Component	Type	Description
Headset	Ritchey Logic Comp	1-1/8" threadless. Black
Crankset	Andel RSC6	24/34/46t. Black
Bottom Bracket	Shimano UN-55	73 x 122mm. Hollow spindle, square taper
Brakes	Avid BB7	Cable actuated. 160mm rotors front & rear
Brake Levers	Avid FR-5	Black
Rims	Alex Adventurer	26". 32-hole. Black w/machined sidewalls
Front Hub	Shimano Deore Disc	Model M529, 32h, QR. Black
Rear Hub	Shimano Deore Disc	Model M529, 32h, QR. Black
Tires	Kenda Kinoption	26 x 2.3". Steel bead
Shifters	Shimano Deore	3 x 9 Rapidfire
Front Derailleur	Shimano Deore	Model 590. 28.6mm. Top pull
Rear Derailleur	Shimano Deore	Model 590SGS. 9-speed
Cog or Cogset	Shimano HG-61	11-13-15-17-20-23-26-30-34t
Stem	Kalloy AS-008	25.4mm bar clamp. Aluminum. 4-bolt face. Black
Handlebar	Surly	Open Bar. 666mm. No rise
Saddle	WTB SST Comp	Steel rails. Black vinyl. Feels pretty o.k.
Seatpost	Kalloy SP-342	27.2mm. 350mm. Black
Chain	SRAM PC-970	Silver
Extras		Surly stainless steel post clamp. 14g DT Swiss spokes

Fork steer tubes are uncut. Pedals not included. Specifications sometimes change. Cope

# MOONLANDER FRAME

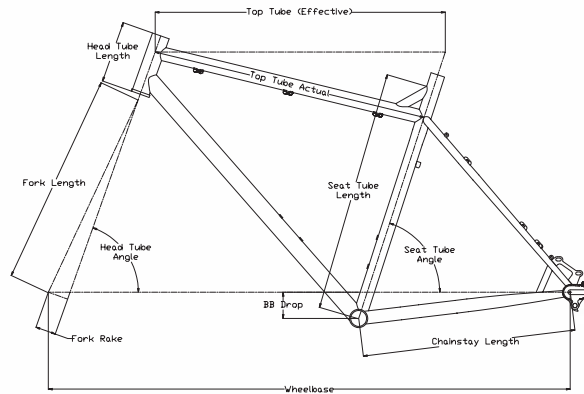

## FRAME GEOMETRY

Size	ST (C-T)		TT (C-C)*		TT (Effective)		HT Angle degrees	ST Angle degrees	BB Drop		CS Length	
	inches	mm	inches	mm	inches	mm			inches	mm	inches	mm
<b>Small</b>	16.0	406.4	21.9	555.2	22.6	575.0	70.5	73.0	2.4	60.0	17.7	450.0
<b>Medium</b>	18.0	457.2	22.5	570.8	23.4	595.5	70.5	73.0	2.4	60.0	17.7	450.0
<b>Large</b>	20.0	508.0	23.2	590.2	24.2	615.0	70.5	73.0	2.4	60.0	17.7	450.0
<b>xLarge</b>	22.0	558.8	23.9	607.3	24.8	630.0	70.5	73.0	2.4	60.0	17.7	450.0
<b>xxLarge</b>	22.0	558.8	24.4	620.6	25.4	645.0	70.5	73.0	2.4	60.0	17.7	450.0

Size	Wheel Base		S.O. Height**		HT Length		FK Length		FK Rake	
	inches	mm	inches	mm	inches	mm	inches	mm	inches	mm
<b>Small</b>	42.3	1073.4	30.4	771.1	4.3	110.0	17.6	447.0	1.7	43.0
<b>Medium</b>	43.1	1093.9	31.5	800.1	4.7	120.0	17.6	447.0	1.7	43.0
<b>Large</b>	43.9	1114.8	32.8	833.8	5.5	140.0	17.6	447.0	1.7	43.0
<b>xLarge</b>	44.5	1130.7	44.5	1130.7	6.3	160.0	17.6	447.0	1.7	43.0
<b>xxLarge</b>	45.1	1146.4	44.9	1140.0	6.9	175.0	17.6	447.0	1.7	43.0

\* All dimensions are preliminary and are subject to change.  
 \*\*Standover height measured using Surly Big Fat Larry tire measuring 762mm in diameter.

## FRAME SPECIFICATIONS

- Tubing:** Surly 4130 CroMoly steel. Main triangle double-buttet. TIG-welded
- Rear dropouts:** Surly horizontal rear load, with derailleur hanger; 135mm O.L.D.; offset 28.0mm
- Brake compatibility:** 51mm IS disc mounts frame and fork. NOTE: Unlike Pugsley, Moonlander uses front caliper adapters for the front brake and rear caliper adapters for the rear brake
- Braze-ons:** Dual water bottle mounts, Surly Trip Guide full line guides for brake and derailleurs, fender and rack eyelets
- Seatpost diameter:** 27.2mm
- Seatpost clamp:** 30.0mm (Surly stainless included)
- Headset/Steertube:** 1-1/8" threadless
- Front derailleur clamp:** Direct mount 28.6mm diameter (adapter included)
- Bottom bracket shell:** 100mm wide, standard English threading (1.37" x 24t)
- Chaining clearance:** 22/36t (NOTE: this is this specific to using a Surly Mr. Whirly offset double crank—use of other cranks may limit number and size of rings and may cause tire/chain rub!)
- Tire clearance:** 4.7" tires on 100mm rims. Hells yes
- Fork:** Tapered straight blade 4130 CroMoly. 51mm IS front disc mount. 135mm-spaced dropouts
- Color:** Space

# MOONLANDER COMPLETE BIKE

## COMPONENT SIZING

Size	Stem Length		Stem Angle degrees	Handlebar Width		Crank Length mm
	inches	mm		inches	mm	
<b>Small</b>	3.5	90.0	7.0	26.0	660.0	170.0
<b>Medium</b>	3.9	100.0	7.0	26.0	660.0	175.0
<b>Large</b>	4.3	110.0	7.0	26.0	660.0	175.0
<b>xLarge</b>	4.7	120.0	7.0	26.0	660.0	180.0
<b>xxLarge</b>	4.7	120.0	7.0	26.0	660.0	180.0

## BIKE SPECIFICATIONS

Component	Type	Description
Headset	Cane Creek 40	1-1/8" threadless. Black
Crankset & BB	Surly Mr. Whirly Offset Double	22/36t
Brakes	Avid BB7	Cable actuated. 160mm rotors front & rear
Brake Levers	Avid SD-7	Black
Rims	Surly Clown Shoes	Single wall aluminum. Welded seam. 100mm width. Black. With cutouts
Front Hub	Surly New Disc 135mm	New model HU0207. Disc. 32-hole. Black
Rear Hub	Shimano XT 135mm	M756. Disc. 32-hole. Black
Tires	Surly Big Fat Larry	26 x 4.7". Larry tread. 120tpi. Ginormous
Shifters	Microshift Thumb Shifters	Model SA-109. 3 x 9
Front Derailleur	Shimano SLX	M661 direct mount via Problem Solvers adapter. Top pull. Black
Rear Derailleur	Shimano Deore	M591-SGS. Black
Cog or Cogset	Shimano HG-61	9-speed 11-12-14-16-18-21-24-28-34t
Stem	Kalloy AS-008	25.4mm bar clamp. 7° rise. 4-bolt face. Aluminum. Black
Handlebar	Salsa MotoAce	17° bend. Black
Saddle	WTB SST Comp	Steel rails. Black vinyl. Feels pretty o.k.
Seatpost	Kalloy SP-342	27.2mm. 350mm. Black
Chain	SRAM PC-971	Silver
Extras		Surly stainless steel post clamp. 14g DT Swiss spokes

Fork steer tubes are uncut. Pedals not included. Specifications sometimes change. Cope.

# PUGSLEY & NECK ROMANCER PUG FRAME

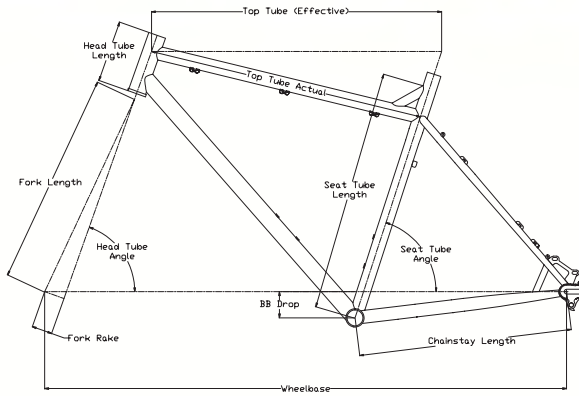

## FRAME GEOMETRY

Size	ST (C-T)		TT (C-C)*		TT (Effective)		HT Angle degrees	ST Angle degrees	BB Drop		CS Length	
	inches	mm	inches	mm	inches	mm			inches	mm	inches	mm
<b>xSmall</b>	14.0	356.5	21.5	545.8	22.0	560.0	70.0	73.0	2.2	55.0	17.6	448.1
<b>Small</b>	16.0	406.4	21.8	554.3	22.9	580.9	70.5	72.0	2.2	55.0	17.6	448.1
<b>Medium</b>	18.0	457.2	22.3	566.5	23.4	595.6	70.5	72.0	2.2	55.0	17.6	448.1
<b>Large</b>	20.0	508.0	22.9	581.9	24.0	610.1	70.5	72.0	2.2	55.0	17.6	448.1
<b>xLarge</b>	22.0	558.8	23.6	600.0	24.6	625.0	70.5	72.0	2.2	55.0	17.6	448.1

Size	Wheel Base		S.O. Height**		HT Length		FK Length		FK Rake	
	inches	mm	inches	mm	inches	mm	inches	mm	inches	mm
<b>xSmall</b>	41.8	1061.6	28.9	734.9	3.7	95.0	17.6	447.0	1.7	43.0
<b>Small</b>	42.0	1067.4	29.9	758.7	4.0	102.0	17.6	447.0	1.7	43.0
<b>Medium</b>	42.6	1082.4	31.0	786.5	4.4	112.0	17.6	447.0	1.7	43.0
<b>Large</b>	43.2	1097.3	32.3	819.6	5.1	130.0	17.6	447.0	1.7	43.0
<b>xLarge</b>	43.8	1112.7	33.6	853.0	5.9	150.0	17.6	447.0	1.7	43.0

\* All dimensions are preliminary and are subject to change.  
 \*\* Standover height measured using Surly Endomorph tire measuring 740mm in diameter.

## FRAME SPECIFICATIONS

- Tubing:** Surly 4130 CroMoly steel. Main triangle double-buttet. TIG-welded
- Rear dropouts:** Surly horizontal rear load, with derailleur hanger; 135mm O.L.D.; offset 17.5mm
- Brake compatibility:** 51mm IS disc mounts frame and fork. NOTE: PLEASE CHECK YOUR FORK SPECIFICATIONS FOR SPECIFIC BRAKE ADAPTOR REQUIREMENTS. SOME OF OUR FORKS USE REAR BRAKE ADAPTORS!
- Braze-ons:** Dual water bottle mounts, Surly Trip Guide full line guides for brake and derailleurs, fender and rack eyelets
- Seatpost diameter:** 27.2mm
- Seatpost clamp:** 30.0mm (Surly stainless included)
- Headset/Steertube:** 1-1/8" threadless
- Front derailleur clamp:** D-type
- Bottom bracket shell:** 100mm wide, standard English threading (1.37" x 24t)
- Chainring clearance:** Compact triple: 22-32-44t (with 65mm rim)
- Tire clearance:** 3.8" on 82mm rims. Use of 82mm rims requires the use of Surly Mr. Whirly Offset Double crank or truncated cassette to avoid tire/chain rub. Standard mountain triple gearing will work with 65mm rims
- Fork:** 447mm axle to crown, tapered straight blade, 4130 CroMoly. 51mm IS REAR disc mount. 135mm-spaced dropouts, 17.5mm offset
- Pugsley Color:** Loaded Yellow or Engine Red
- Neck Romancer Pug Color:** Burned Nougat

# PUGSLEY & NECK ROMANCER COMPLETE BIKE

## COMPONENT SIZING

Size	Stem Length		Stem Angle degrees	Handlebar Width		Crank Length mm
	inches	mm		inches	mm	
<b>xSmall</b>	3.5	90.0	7.0	26.0	660.0	170.0
<b>Small</b>	3.9	100.0	7.0	26.0	660.0	170.0
<b>Medium</b>	4.3	110.0	7.0	26.0	660.0	175.0
<b>Large</b>	4.7	120.0	7.0	26.0	660.0	175.0
<b>xLarge</b>	4.7	120.0	7.0	26.0	660.0	175.0

## BIKE SPECIFICATIONS

Component	Pugsley	Neck Romancer
Headset	Ritchey	Cane Creek 40
Crankset	TV Husseflet 44/32/22	Surly MWOD 36/22
Brakes	Avid BB7	Avid BB7
Brake Levers	Avid FR-5	Avid FR-5
Rims	Surly Marge Lite	Surly Rolling Darryl
Front Hub	Surly Ultra New	Surly Ultra New
Rear Hub	Shimano Deore	Shimano Deore
Front/Rear Tires	Larry/Endo	Larry/Nate
Shifters	Microshift SL-T09	Microshift SL-T09
Front Derailleur	SLX Direct Mount	SLX Direct Mount
Rear Derailleur	Deore RD M591 SGSL	Deore RD M591 SGSL
Cog or Cogset	HG61 9-speed 11/32t	HG61 9-speed 11/34t
Stem	Kalloy 4-bolt	Kalloy 4-bolt
Handlebar	Salsa Moto Ace 17°	Salsa Moto Ace 17°
Saddle	WTB SST comp	WTB SST comp
Seatpost	Kalloy 27.2 x 350mm	Kalloy 27.2 x 350mm
Chain	SRAM PC-971	SRAM PC-971
Extras	Surly stainless steel post clamp. Surly toobs. DT Swiss Champion spokes	Surly stainless steel post clamp (black). Surly toobs. DT Swiss Champion spokes (black!). 12mm brass nipples -yup, black

Fork steer tubes are uncut. Pedals not included. Specifications sometimes change. Cope.

# LONG HAUL, DELUXE & DISC TRUCKER FRAMES

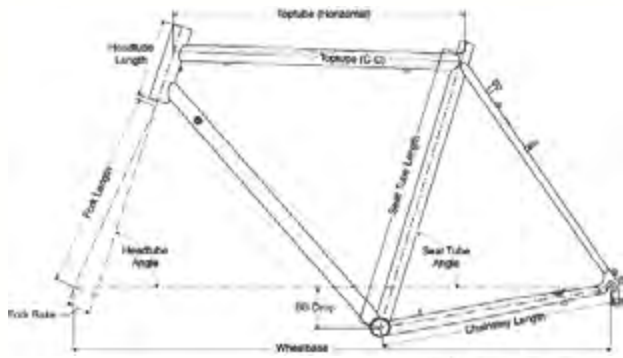

Long Haul Trucker & Trucker Deluxe

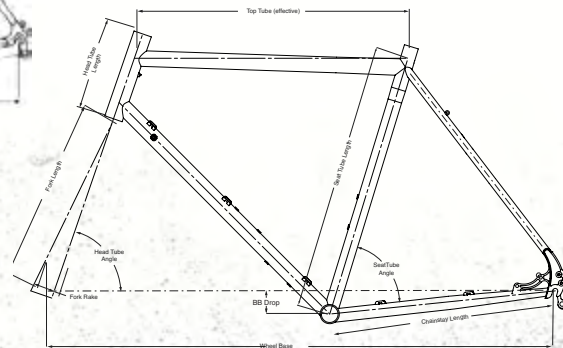

Disc Trucker

## FRAME SPECIFICATIONS

**Sizes:** 26" wheel 42, 46, 50-62cm; 700c wheel 56-64cm (frame only in 64cm, no 700c DeLuxe)

**Tubing:** 100% Surly 4130 CroMoly steel. Main triangle double-buttet. TIG-welded

**Rear dropouts:** Vertical, 135mm O.L.D.

**Brake compatibility:** LHT and DeLuxe use rim brake pivots front and rear (cantilever or linear pull)  
Disc Trucker uses 51mm disc calipers (160mm rotor only)

**Braze-ons:** Upper bosses and dropout eyelets for racks front and rear, fender eyelets, pump peg, downtube lever bosses, three sets of H<sub>2</sub>O cage bosses, rear housing stop for rim brakes (LHT and DeLuxe), housing stops for brake and derailleurs, S&S couplers (DeLuxe)

**Seatpost diameter:** 27.2mm

**Seatpost clamp:** 30.0mm (Surly stainless included)

**Headset/Steertube:** 1-1/8" threadless

**Front derailer clamp:** 28.6mm (bottom pull)

**Bottom bracket shell:** 68mm wide, threaded standard English (1.37" x 24t)

**Chainring clearance:** 42/53t double, 38/52/56t triple

**Tire clearance:** 26": 2.1" with or without fenders; 700c: 42mm with fenders, 45mm without fenders  
Individual tire and rim combos affect tire clearance

**Fork:** 4130 CroMoly, lugged and brazed. Proprietary sloping crown with threaded eyelets, tapered curved blades with mid-blade rack eyelets, dual dropout eyelets

**LHT & Disc Trucker Color:** Smoggy Pearl or Blacktacular

**Disc Trucker Colors:** Super Dark Green

**Trucker DeLuxe Color:** Dave's Frozen Tears

## 700c WHEELS

Size	ST (C-T)		TT (C-C)*		TT (Effective)		HT Angle		ST Angle		BB Drop		CS Length	
	inches	mm	inches	mm	inches	mm	degrees	degrees	inches	mm	inches	mm	inches	mm
56cm	2.2	56.0	22.2	564.5	22.4	570.0	72.0	73.0	3.1	78.0	18.1	460.0		
58cm	2.3	58.0	22.8	580.2	23.1	586.0	72.0	72.5	3.1	78.0	18.1	460.0		
60cm	2.4	60.0	23.4	594.8	23.6	600.0	72.0	72.5	3.1	78.0	18.1	460.0		
62cm	2.4	62.0	23.8	603.9	24.0	610.0	72.0	72.0	3.1	78.0	18.1	460.0		
64cm	25.2	640.0	24.4	615.0	24.4	620.0	72.0	72.0	3.1	78.0	18.1	460.0		

Size	Wheel Base		S. O. Height**		HT Length		FK Length		FK Rake	
	inches	mm	inches	mm	inches	mm	inches	mm	inches	mm
56cm	41.6	1055.6	32.0	811.9	6.0	152.0	15.4	390.0	1.8	45.0
58cm	42.0	1066.7	32.7	829.8	6.7	171.0	15.4	390.0	1.8	45.0
60cm	42.6	1080.8	33.4	847.8	7.4	189.0	15.4	390.0	1.8	45.0
62cm	42.7	1085.3	34.1	866.5	8.3	210.0	15.4	390.0	1.8	45.0
64cm	43.1	1095.3	34.8	883.6	8.9	226.0	15.4	390.0	1.8	45.0

\*All dimensions subject to change.

\*\*Measurements for 700c frame are calculated using a tire with a diameter of 690mm.

## 26" WHEELS

Size	ST (C-T)		TT (C-C)*		TT (Effective)		HT Angle		ST Angle		BB Drop		CS Length	
	inches	mm	inches	mm	inches	mm	degrees	degrees	inches	mm	inches	mm	inches	mm
42cm	1.7	42.0	19.4	492.7	19.9	505.0	70.0	75.0	1.9	47.0	18.1	460.0		
46cm	1.8	46.0	20.0	508.4	20.3	515.0	70.0	74.5	1.9	47.0	18.1	460.0		
50cm	2.0	50.0	20.7	525.4	20.9	530.0	71.0	74.0	1.9	47.0	18.1	460.0		
52cm	2.0	52.0	21.1	535.0	21.3	540.0	71.0	73.5	1.9	47.0	18.1	460.0		
54cm	2.1	54.0	21.6	549.7	21.9	555.0	71.0	73.0	1.9	47.0	18.1	460.0		
56cm	2.2	56.0	22.2	564.5	22.4	570.0	71.0	73.0	1.9	47.0	18.1	460.0		
58cm	2.3	58.0	22.8	580.3	23.1	586.0	71.0	72.5	1.9	47.0	18.1	460.0		
60cm	2.4	60.0	23.4	594.8	23.6	600.0	71.5	72.5	1.9	47.0	18.1	460.0		
62cm	2.4	62.0	23.8	603.8	24.0	610.0	71.5	72.0	1.9	47.0	18.1	460.0		

Size	Wheel Base		S. O. Height**		HT Length		FK Length		FK Rake	
	inches	mm	inches	mm	inches	mm	inches	mm	inches	mm
42cm	40.8	1036.6	27.6	702.1	4.4	110.7	14.8	376.0	1.8	45.0
46cm	41.1	1042.7	28.5	723.2	4.6	116.7	14.8	376.0	1.8	45.0
50cm	41.2	1046.8	29.8	756.1	5.7	144.0	14.8	376.0	1.8	45.0
52cm	41.5	1053.1	30.5	774.5	6.4	163.0	14.8	376.0	1.8	45.0
54cm	41.9	1064.0	31.2	792.4	7.2	182.0	14.8	376.0	1.8	45.0
56cm	42.5	1079.8	32.0	811.9	8.0	203.0	14.8	376.0	1.8	45.0
58cm	43.0	1091.2	32.7	829.7	8.7	222.0	14.8	376.0	1.8	45.0
60cm	43.3	1100.4	33.4	847.9	9.4	238.0	14.8	376.0	1.8	45.0
62cm	43.5	1105.1	34.1	866.6	10.2	259.0	14.8	376.0	1.8	45.0

\*All dimensions subject to change.

\*\*Measurements for 26" frame are calculated using a tire with a diameter of 628mm.

# LONG HAUL TRUCKER COMPLETE BIKE

# DISC TRUCKER COMPLETE BIKE

## COMPONENT SIZING

Size	Stem Length		Stem Angle degrees	Handlebar Width		Crank Length mm
	inches	mm		inches	mm	
<b>42cm</b>	3.0	75.0	35.0	15.7	400.0	165.0
<b>46cm</b>	3.0	75.0	35.0	15.7	400.0	165.0
<b>50cm</b>	3.0	75.0	35.0	15.7	400.0	170.0
<b>52cm</b>	3.5	90.0	17.0	16.5	420.0	170.0
<b>54cm</b>	3.9	100.0	17.0	16.5	420.0	170.0
<b>56cm</b>	3.9	100.0	17.0	16.5	440.0	175.0
<b>58cm</b>	4.3	110.0	17.0	17.3	440.0	175.0
<b>60cm</b>	4.7	120.0	17.0	18.1	460.0	175.0
<b>62cm</b>	4.7	120.0	17.0	18.1	460.0	175.0
<b>64cm</b>	4.7	120.0	17.0	18.1	460.0	175.0

## COMPONENT SIZING

Size	Stem Length		Stem Angle degrees	Handlebar Width		Crank Length mm
	inches	mm		inches	mm	
<b>42cm</b>	3.0	75.0	35.0	15.7	400.0	165.0
<b>46cm</b>	3.0	75.0	35.0	15.7	400.0	165.0
<b>50cm</b>	3.0	75.0	35.0	15.7	400.0	170.0
<b>52cm</b>	3.5	90.0	17.0	16.5	420.0	170.0
<b>54cm</b>	3.9	100.0	17.0	16.5	420.0	170.0
<b>56cm</b>	3.9	100.0	17.0	16.5	440.0	175.0
<b>58cm</b>	4.3	110.0	17.0	17.3	440.0	175.0
<b>60cm</b>	4.7	120.0	17.0	18.1	460.0	175.0
<b>62cm</b>	4.7	120.0	17.0	18.1	460.0	175.0
<b>64cm</b>	4.7	120.0	17.0	18.1	460.0	175.0

## BIKE SPECIFICATIONS

Component	Type	Description
Headset	Cane Creek 40	1-1/8" threadless. Black
Crankset	Andel RSC6	26/36/48t. Square taper interface. Silver
Bottom Bracket	Shimano UN-54	Square taper interface. 68 x 118mm
Brakes	Tektro	CR720 cantilever. Silver
Brake Levers	Tektro	RL341 short reach on 42, 46, 50mm frames. RL340 standard reach on all others
Rims (26")	Alex Adventurer	36h. Double wall. Eyeletted. Black
Rims (700c)	Alex Adventurer	36h. Double wall. Eyeletted. Black
Front Hub	Shimano LX	T660. 36h. Non-disc. Silver
Rear Hub	Shimano LX	T660. 36h. Non-disc. 135mm O.L.D. Silver
Tires (26") 42-54cm	Continental Contact	26 x 1.5". Wire bead. Blackwall
Tires (26") 56-62cm	Michelin City	26 x 1.5". Wire bead. Blackwall
Tires (700c)	Continental Contact	700c x 37mm. Wire bead. Blackwall
Shifters	Shimano bar-end	SL-BS77 2/3 x 9-speed, friction setting
Front Derailleur	Shimano Sora	FD-3403. Silver
Rear Derailleur	Shimano LX	T661SGS. Black
Cog or Cogset	Shimano HG-50	11-13-15-17-20-23-26-30-34t
Stem	Kalloy AS-009	26.0mm bar clamp. Aluminum. 4-bolt face. Silver
Handlebar	PMT	Silver
Saddle	WTB SST Comp	Steel rails. Black vinyl. Feels pretty o.k.
Seatpost	Kalloy SP-248D	27.2mm. 300mm. Silver
Chain	SRAM PC-971	Silver. 116 links
Extras		Surly stainless steel post clamp. 14g DT Swiss spokes. Some pretty sweet & comfy cork tape

## BIKE SPECIFICATIONS

Component	Type	Description
Headset	Cane Creek 40	1-1/8" threadless. Black
Crankset	Andel RSC6	26/36/48t. Square taper interface. Silver
Bottom Bracket	Shimano UN-54	Square taper interface. 68 x 118mm
Brakes	Avid BB7	Cable actuated. 160mm rotors front & rear
Brake Levers	Tektro RL520	Drop bar levers. Black hoods
Rims (26")	Alex Adventurer	36h. Double wall. Eyeletted. Black
Rims (700c)	Alex Adventurer	36h. Double wall. Eyeletted. Black
Front Hub	Shimano XT	M756 6-bolt disc. 36h. Silver
Rear Hub	Shimano XT	M756 6-bolt disc. 36h. 135mm. Silver
Tires (26") 42-54cm	Continental Contact	26 x 1.5". Wire bead. Blackwall
Tires (26") 56-62cm	Michelin City	26 x 1.5". Wire bead. Blackwall
Tires (700c)	Continental Contact	700c x 37mm. Wire bead. Blackwall
Shifters	Shimano bar-end	SL-BS77 2/3 x 9-speed, friction setting
Front Derailleur	Shimano Sora	FD-3403. Silver
Rear Derailleur	Shimano LX	T661SGS. Black
Cog or Cogset	Shimano HG-50	11-13-15-17-20-23-26-30-34t
Stem	Kalloy AS-009	26.0mm bar clamp. Aluminum. 4-bolt face. Silver
Handlebar	PMT	Silver
Saddle	WTB SST Comp	Steel rails. Black vinyl. Feels pretty o.k.
Seatpost	Kalloy SP-248D	27.2mm. 300mm. Silver
Chain	SRAM PC-971	Silver. 116 links
Extras		Surly stainless steel post clamp. 14g DT Swiss spokes. Some pretty sweet & comfy cork tape

Fork steer tubes are uncut. Pedals not included. Specifications sometimes change. Cope.

Fork steer tubes are uncut. Pedals not included. Specifications sometimes change. Cope.

# PACER FRAME

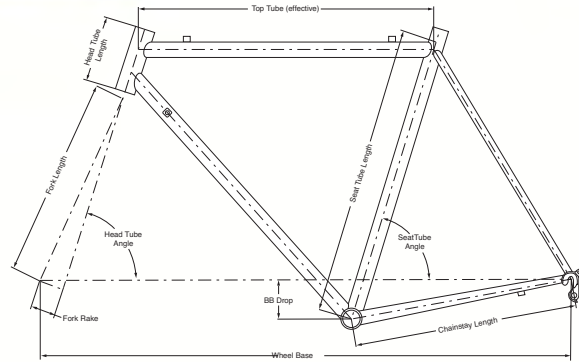

## FRAME GEOMETRY

Size	ST (C-T)		TT (C-C)*		TT (Effective)		HT Angle		ST Angle		BB Drop		CS Length	
	inches	mm	inches	mm	inches	mm	degrees	degrees	inches	mm	inches	mm	inches	mm
42cm	16.5	420.0	19.5	494.1	20.0	508.5	71.0	75.5	2.8	72.0	16.1	410.0		
46cm	18.1	460.0	19.9	504.2	20.2	514.3	71.5	75.5	2.8	72.0	16.1	410.0		
50cm	19.7	500.0	20.6	522.9	20.7	526.4	72.0	74.5	2.8	72.0	16.1	410.0		
52cm	20.5	520.0	21.3	540.0	21.3	540.0	72.5	74.0	2.8	72.0	16.1	410.0		
54cm	21.3	540.0	21.9	555.0	21.9	555.0	72.5	73.5	2.8	72.0	16.3	415.0		
56cm	22.0	560.0	22.2	565.0	22.2	565.0	73.0	73.0	2.8	72.0	16.3	415.0		
58cm	22.8	580.0	22.8	579.4	22.8	579.4	73.5	73.0	2.8	72.0	16.3	415.0		
60cm	23.6	600.0	23.2	590.0	23.2	590.0	73.5	72.5	2.8	72.0	16.3	415.0		
62cm	24.4	620.0	23.8	605.0	23.8	605.0	74.0	72.5	2.8	72.0	16.3	415.0		

Size	Wheel Base		S.O. Height**		HT Length		FK Length		FK Rake	
	inches	mm	inches	mm	inches	mm	inches	mm	inches	mm
42cm	38.6	980.9	28.5	723.7	3.3	84.0	14.8	376.0	2.0	50.0
46cm	38.7	982.9	29.3	744.9	3.9	99.0	14.8	376.0	2.0	50.0
50cm	38.8	985.6	30.1	764.4	3.9	99.0	14.8	376.0	2.0	50.0
52cm	38.9	987.2	30.5	775.9	4.1	104.0	14.8	376.0	2.0	50.0
54cm	39.1	992.8	31.2	793.7	4.7	119.0	14.8	376.0	1.8	45.0
56cm	39.3	998.8	31.9	811.5	5.4	136.0	14.8	376.0	1.8	45.0
58cm	39.7	1008.6	32.7	830.7	6.1	154.0	14.8	376.0	1.8	45.0
60cm	39.9	1013.7	33.4	848.3	6.7	171.0	14.8	376.0	1.8	45.0
62cm	40.3	1023.4	34.1	867.3	7.4	189.0	14.8	376.0	1.8	45.0

\* All dimensions are preliminary and are subject to change.  
 \*\*Standover height is based on a 700c x 25mm measuring 680mm in diameter.

## FRAME SPECIFICATIONS

- Tubing:** Surly 4130 CroMoly steel. Main triangle double-butted. TIG-welded
- Rear dropouts:** Vertical dropouts, 130mm spaced; with eyelet
- Brake compatibility:** Mid-reach (47-57mm) road calipers
- Braze-ons:** Single fender eyelets front and rear, dual water bottle mounts, and pump peg (54cm and larger)
- Seatpost diameter:** 27.2mm
- Seatpost clamp:** 30.0mm Surly stainless, included
- Headset:** 1-1/8" threadless
- Front derailleur clamp diameter:** 28.6mm
- Bottom bracket shell:** 68mm wide, threaded English 1.37" x 24t
- Chainring clearance:** 39/53t
- Tire clearance:** Room for 700c x 32mm or 700c x 28mm with fenders
- Color:** Sparkleboogie Blue

# PACER COMPLETE BIKE

## COMPONENT SIZING

Size	Stem Length		Stem Angle	Handlebar Width		Crank Length
	inches	mm	degrees	inches	mm	mm
42cm	3.1	80.0	7.0	15.7	400.0	170.0
46cm	3.1	80.0	7.0	15.7	400.0	170.0
50cm	3.5	90.0	7.0	15.7	400.0	170.0
52cm	3.5	90.0	7.0	16.5	420.0	170.0
54cm	3.9	100.0	7.0	16.5	420.0	170.0
56cm	3.9	100.0	7.0	17.3	440.0	172.5
58cm	4.3	110.0	7.0	17.3	440.0	175.0
60cm	4.7	120.0	7.0	18.1	460.0	175.0
62cm	4.7	120.0	7.0	18.1	460.0	175.0

## BIKE SPECIFICATIONS

Component	Type	Description
Headset	Cane Creek 40	1-1/8" threadless. Black
Crankset	Andel RSC2	RSC2-217XR. 34/50t. Silver
Bottom bracket	Shimano UN-54	68 x 110mm. Square taper interface
Brakes	Tektro R358	Dual pivot. Standard reach (47-57mm). Silver
Rims	Alex R390	32h. Black
Front Hub	Shimano Tiagra	HB4600. 32h. Silver
Rear Hub	Shimano Tiagra	FH4600. 32h. 130mm O.L.D. Silver
Tires	Continental Ultra Sport	28mm. Steel bead. Black
Brake/Shift Levers	Shimano Tiagra	ST4600
Front Derailleur	Shimano Tiagra	FD4600
Rear Derailleur	Shimano Tiagra	RD4600-SS. Silver
Cog or Cogset	Shimano Tiagra	CS-4600. 12-28t
Stem	KALLOY AS-008	26.0mm bar clamp. Silver
Handlebar	Salsa MotoAce Short & Shallow	Silver
Saddle	WTB SST Comp	Steel rails. Black vinyl. Feels pretty o.k.
Seatpost	Kalloy SP-342	27.2mm. 350mm. Black
Chain	SRAM PC-1071	10-speed. Silver
Extras		Surly stainless steel post clamp. Cushy cork bar tape

Fork steer tubes are uncut. Pedals not included. Specifications sometimes change. Cope.

# CROSS-CHECK FRAME

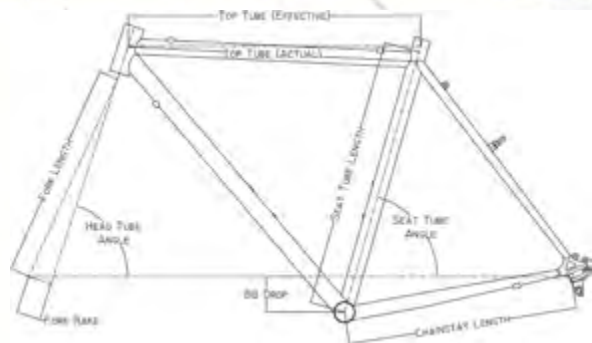

## FRAME GEOMETRY

Size	ST (C-T)		TT (C-C)*		TT (Effective)		HT Angle	ST Angle	BB Drop		CS Length	
	inches	mm	inches	mm	inches	mm	degrees	degrees	inches	mm	inches	mm
42cm	16.5	420.0	19.9	505.0	20.6	522.0	72.0	75.0	2.6	66.0	16.5	420.0
46cm	18.1	460.0	20.3	515.0	20.8	528.8	72.0	74.5	2.6	66.0	16.5	420.0
50cm	19.7	500.0	21.1	535.1	21.3	541.8	72.0	74.0	2.6	66.0	16.7	425.0
52cm	20.5	520.0	21.5	545.1	21.5	547.1	72.0	73.5	2.6	66.0	16.7	425.0
54cm	21.3	540.0	22.0	559.9	22.0	560.0	72.0	73.0	2.6	66.0	16.7	425.0
56cm	22.0	560.0	22.4	569.9	22.4	570.0	72.0	72.5	2.6	66.0	16.7	425.0
58cm	22.8	580.0	22.8	579.8	22.8	580.0	72.0	72.5	2.6	66.0	16.7	425.0
60cm	23.6	600.0	23.6	599.8	23.6	600.0	72.0	72.0	2.6	66.0	16.7	425.0
62cm	24.4	620.0	24.0	609.9	24.0	610.0	72.0	72.0	2.6	66.0	16.7	425.0

Size	Wheel Base		S.O. Height**		HT Length		FK Length		FK Rake	
	inches	mm	inches	mm	inches	mm	inches	mm	inches	mm
42cm	39.0	989.8	28.8	731.9	3.6	91.0	15.7	400.0	1.7	44.0
46cm	39.1	991.9	29.6	750.7	3.6	91.0	15.7	400.0	1.7	44.0
50cm	39.6	1005.2	30.3	769.4	3.6	91.0	15.7	400.0	1.7	44.0
52cm	39.6	1005.9	30.6	778.4	3.6	91.0	15.7	400.0	1.7	44.0
54cm	39.9	1014.3	31.2	793.0	4.0	102.0	15.7	400.0	1.7	44.0
56cm	40.1	1019.7	31.9	810.7	4.8	121.0	15.7	400.0	1.7	44.0
58cm	40.6	1029.9	32.7	829.9	5.6	141.0	15.7	400.0	1.7	44.0
60cm	41.1	1044.7	33.4	847.4	6.3	160.0	15.7	400.0	1.7	44.0
62cm	41.5	1054.7	34.1	866.2	7.1	180.0	15.7	400.0	1.7	44.0

\* All dimensions are preliminary and are subject to change.

\*\*Measurements use tire with 685mm outer diameter (Ritchey 700c x 30mm SpeedMax), and taken from middle of toptube to level ground.

## FRAME SPECIFICATIONS

**Tubing:** Surly 4130 CroMoly steel. Main triangle double-buttet. TIG-welded

**Rear dropouts:** Semi-horizontal dropouts give you singlespeed compatibility and wheelbase adjustability. Adjuster screws are included to keep your wheel in the right place for optimal shifting if you go with derailleurs. Our Gnot-rite spacing (132.5mm) allows you to run 130mm road hubs and 135mm MTB hubs

**Braze-ons:** Bosses front and rear to take cantilever or linear-pull brakes, eyelets at the dropouts, rear rack bosses, dual water bottle mounts, downtube shifter bosses, fully threaded through-blade fork eyelets for a front rack

**Seatpost diameter:** 27.2mm

**Seatpost clamp:** 30.0mm Surly stainless, included

**Headset/Stem:** 1-1/8" threadless

**Bottom bracket:** 68mm wide, standard English threaded 1.37" x 24t

**Tire clearance:** Fatties Fit Fine (FFF) stays and our beautiful slope-crowned custom fork provide room for tires up to 700c x 45mm, or about 700c x 40mm with fenders. Largest possible tire size depends on tire, rims, axle location in the dropouts, and other factors, but still, you can run pretty damn big tires

**Chainring clearance:** Manipulated stays so you can fit the size rings you want. Go nuts

**Color:** Hospital Foam or Gloss Black **Singlespeed Colors:** Black Blue

# CROSS-CHECK COMPLETE BIKE

## COMPONENT SIZING

Size	Stem Length		Stem Angle	Handlebar Width		Crank Length
	inches	mm	degrees	inches	mm	mm
42cm	2.8	70.0	83.0	15.7	400.0	170.0
46cm	3.1	80.0	83.0	15.7	400.0	170.0
50cm	3.1	80.0	83.0	15.7	400.0	170.0
52cm	4.1	100.0	97.0	16.5	420.0	170.0
54cm	4.1	100.0	97.0	16.5	420.0	175.0
56cm	4.1	100.0	97.0	17.3	440.0	175.0
58cm	4.7	120.0	97.0	17.3	440.0	175.0
60cm	4.7	120.0	97.0	18.1	460.0	175.0
62cm	4.7	120.0	97.0	18.1	460.0	175.0

\*\*Stems can be flip-flopped to customize angle

## BIKE SPECIFICATIONS

Component	Geared	Singlespeed
Headset	Cane Creek 40	Cane Creek 10, 1 1/8", Black
Crankset	Andel RSC6. 36/48t. Black	Andel 42T, Black. Shimano UN-55 BB
Bottom Bracket	Shimano UN-54 68 x 107mm. Square taper interface	Shimano UN-54 68 x 107mm. Square taper interface
Brakes	Tektro cantilever. CR720 Black	Avid SD-5, Black
Brake Levers	Tektro RL341 short reach on 42, 46 & 50mm frames. RL340 standard reach on all others	Avid FR5, Black
Rims	Alex DA-16 700c. Double wall. 32h	Alex DA-16 700c. Double wall. 32h
Hubs	Shimano Deore. M590. QR. 32h. Black	Surly Ultra New. 100mm front, 135mm rear. Black
Tires	Kenda Slant 6. 700 x 35 wire bead	Conti Tour Ride 700 x 42mm, wire bead, W/O reflective strip
Shifters	Microshift bar-end. 2/3 x 9-speed, friction setting	Its a Singlespeed!
Front Derailleur	Shimano Sora. FD-3403. Silver	Nope
Rear Derailleur	Shimano Deore. M591SGS. Long cage. Black	None
Cog or Cogset	Shimano Tiagra HG50. 11-32t	17t Freewheel, Shimano
Stem	Kalloy AS-008, 26.0mm bar clamp. Aluminum, 4-bolt face. Black	Kalloy AS-008, 31.8, Black
Handlebar	Salsa Bell Lap, Black	Salsa Moto-Ace, 31.8, Black
Saddle	WTB SST Comp, Steel rails. Black vinyl. Feels...not bad	WTB SST Comp
Seatpost	Kalloy SP-342, 27.2mm. 300mm. Black	Kalloy SP-342, 27.2mm. 300mm. Black
Chain	SRAM PC-971, Silver	KMC X8
Extras	Surly stainless steel post clamp. 14g DT Swiss spokes. Some pretty sweet & comfy cork tape	Stainless Surly seatpost clamp, Love.

Fork steer tubes are uncut. Pedals not included. Specifications sometimes change. Cope.



# STEAMROLLER FRAME

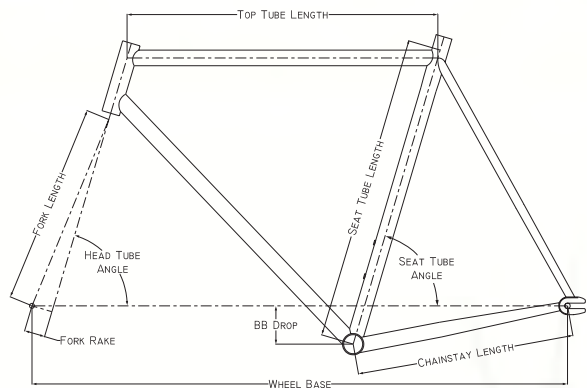

## FRAME GEOMETRY

Size	ST (C-T)		TT (C-C)*		TT (Effective)		HT Angle degrees	ST Angle degrees	BB Drop		CS Length	
	inches	mm	inches	mm	inches	mm			inches	mm	inches	mm
49cm	19.3	490.0	20.7	526.5	20.8	529.5	72.5	74.5	2.8	70.0	15.7	398.0
53cm	20.9	530.0	21.5	547.0	21.5	547.0	73.0	74.0	2.8	70.0	15.7	398.0
56cm	22.0	560.0	22.4	568.0	22.4	568.0	73.5	73.5	2.8	70.0	15.7	398.0
59cm	23.2	590.0	23.1	587.0	23.1	587.0	74.0	73.0	2.8	70.0	15.7	398.0
62cm	24.4	620.0	23.9	608.0	23.9	608.0	74.0	73.0	2.8	70.0	15.7	398.0

\* All dimensions are preliminary and are subject to change.

\*\*Measurements use tire with outer diameter of 682mm (700c x 28mm), and taken from middle of toptube to level ground.

Size	Wheel Base		S.O. Height**		HT Length		FK Length		FK Rake	
	inches	mm	inches	mm	inches	mm	inches	mm	inches	mm
49cm	38.0	965.7	29.5	748.5	3.3	83.0	14.8	375.0	1.5	38.0
53cm	38.1	966.6	30.7	780.5	4.3	109.0	14.8	375.0	1.5	38.0
56cm	38.5	978.6	31.8	807.9	5.4	136.0	14.8	375.0	1.5	38.0
59cm	38.9	987.6	32.9	835.2	6.4	163.0	14.8	375.0	1.5	38.0
62cm	39.7	1009.1	34.1	865.3	7.7	196.0	14.8	375.0	1.5	38.0

\* All dimensions are preliminary and are subject to change.

\*\*Measurements use tire with outer diameter of 682mm (700c x 28mm), and taken from middle of toptube to level ground.

## FRAME SPECIFICATIONS

**Tubing:** Surly 4130 CroMoly steel. Main triangle is double-butted. TIG-welded

**Rear dropouts:** Investment cast Surly track dropouts, 120mm spaced

**Brake compatibility:** Standard reach post-mount road callipers, but there are no stops for housing

**Braze-ons:** None, baby. Pure. OK, we put one set of water-bottle mounts on the seattube 'cause we're not camels

**Seatpost diameter:** 27.2mm

**Seatpost clamp:** 30.0mm Surly stainless, included

**Headset:** 1-1/8" threadless

**Bottom bracket shell:** 68mm wide, threaded English 1.37" x 24t

**Tire clearance:** Room for tires up to 700c x 38mm. Individual tire and rim combos affect tire clearance, but figure on being able to use tires up to 32mm with fenders (p.s. use clip-on fenders)

**Chainring clearance:** Heavy manipulation of the chainstays gives room for a 50t ring while maintaining chainline. Track crank-compatible

**Color:** GrayGreen or Superblack

# STEAMROLLER COMPLETE BIKE

## COMPONENT SIZING

Size	Stem Length		Stem Angle degrees	Handlebar Width		Crank Length mm
	inches	mm		inches	mm	
49cm	4.3	110.0	7.0	26.2	666.0	165.0
53cm	4.3	110.0	7.0	26.2	666.0	165.0
56cm	4.7	120.0	7.0	26.2	666.0	165.0
59cm	4.7	120.0	7.0	26.2	666.0	170.0
62cm	5.1	130.0	7.0	26.2	666.0	170.0

\*\*Stems can be flip-flopped to customize angle

## BIKE SPECIFICATIONS

Component	Type	Description
Headset	Ritchey Logic Comp	1-1/8" threadless. Steel. Black
Crankset	Andel	Forged arms. 44t. 3/32" chain compatible. Black
Bottom Bracket	T.H.C. (yeah! For real!)	68 x 103mm. Square taper interface
Brakes	Tektro R538	Dual pivot. Standard reach (47-57mm). Black
Brake Levers	Tektro MT2.1	Black & silver
Rims	Alex DA-22	32h. Black
Front Hub	Surly New	32h. Black
Rear Hub	Surly New	32h. Black. Fixed/free threading
Tires	Continental Tour Ride	32mm. Blackwall
Cog	Surly 3/32" fixed gear	19t
Stem	Kalloy AS-009	25.4mm bar clamp. Aluminum. 4-bolt face. Black
Handlebar	Surly Open Bar	No rise. Black
Saddle	WTB SST Comp	Steel rails. Black vinyl
Seatpost	Kalloy SP-248D	27.2mm. 300mm. Black
Chain	KMC X8.9	Yup
Extras		Surly stainless steel post clamp. Surly stainless steel cog locking

Fork steer tubes are uncut. Pedals not included. Specifications sometimes change. Cope.

# BIG DUMMY FRAME

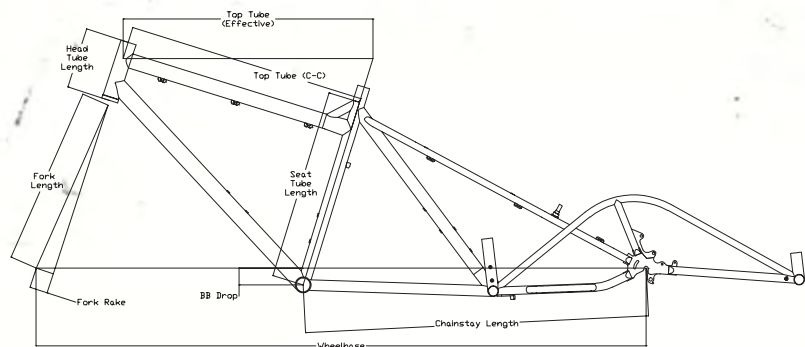

## FRAME GEOMETRY

Size	ST (C-T)		TT (C-C)*		TT (Effective)		HT Angle degrees	ST Angle degrees	BB Drop		CS Length	
	inches	mm	inches	mm	inches	mm			inches	mm	inches	mm
<b>Small</b>	16.0	406.4	21.7	550.6	22.6	573.5	72.0	73.0	1.6	40.0	32.6	827.0
<b>Medium</b>	18.0	457.2	22.4	570.1	23.5	596.1	72.0	73.0	1.6	40.0	32.6	827.0
<b>Large</b>	20.0	508.0	23.2	588.7	24.2	614.1	72.0	73.0	1.6	40.0	32.6	827.0
<b>X-Large</b>	22.0	558.8	24.0	609.6	24.9	631.8	72.0	73.0	1.6	40.0	32.6	827.0

Size	Wheel Base		S.O. Height**		HT Length		FK Length		FK Rake	
	inches	mm	inches	mm	inches	mm	inches	mm	inches	mm
<b>Small</b>	56.5	1435.9	29.1	740.4	5.2	131.7	16.7	425.0	1.7	43.0
<b>Medium</b>	57.4	1458.8	30.4	771.5	5.7	145.9	16.7	425.0	1.7	43.0
<b>Large</b>	58.1	1477.0	31.6	802.9	6.3	160.8	16.7	425.0	1.7	43.0
<b>X-Large</b>	58.9	1495.0	32.9	835.8	7.0	178.8	16.7	425.0	1.7	43.0

\* All dimensions are preliminary and are subject to change.  
 \*\*Measurements use tire with diameter of 676mm (average 26 x 2.1").

## FRAME SPECIFICATIONS

- Tubing:** Surly 4130 CroMoly steel. Main triangle double-buttet. TIG-welded
- Rear dropouts:** Vertical, 135mm spaced with fender eyelets
- Brake compatibility:** 51mm disc mounts and removable cantilever pivots
- Braze-ons:** Triple water bottle mounts, Surly Trip Guides for continuous brake/shift housing or brake hydraulic line (toptube and seatstay routing), fender eyelets
- Seatpost diameter:** 27.2mm
- Seatpost clamp:** 30mm Surly stainless, included
- Headset:** 1-1/8" threadless
- Front derailleur:** 28.6mm (1-1/8") clamp diameter, top-pull style
- Bottom bracket shell:** 68mm wide, threaded English 1.37" x 24t
- Tire clearance:** 26 x 2.5" with fenders
- Chaining clearance:** No frame limitations. Use whatever you want
- Fork:** TIG-welded 4130 CroMoly, suspension-corrected (80mm travel), tapered straight blade with single fender eyelet on the dropout, 1-1/8" x 260mm threadless steerer, 51mm IS disc mount, removable cantilever pivots, line/housing guides
- Cargo Weight Limit:** 400 lb combined rider and cargo
- Color:** Tar Pit Black

# BIG DUMMY COMPLETE BIKE

## COMPONENT SIZING

Size	Stem Length		Stem Angle degrees	Handlebar Width		Crank Length mm
	inches	mm		inches	mm	
<b>Small</b>	3.5	90.0	7.0	26.0	660.0	170.0
<b>Medium</b>	3.9	100.0	7.0	26.0	660.0	175.0
<b>Large</b>	4.3	110.0	7.0	26.0	660.0	175.0
<b>X-Large</b>	4.7	120.0	7.0	26.0	660.0	175.0

## BIKE SPECIFICATIONS

Component	Type	Description
Headset	Cane Creek 40	1-1/8" threadless. Black
Crankset & BB	TruVativ FireX C3.1	Forged aluminum. 48-36-26t. Black
Brakes	Avid BB7	Cable actuated. 185mm rotors front & rear
Brake Levers	Avid FR-5	Black
Rims	Salsa Gordo	36h. Black w/machined sidewalls
Front & Rear Hubs	Shimano Deore	M529 Disc. 36h. Black
Tires	Continental Town & Country	26 x 2.1". Steel bead
Shifters	Shimano Deore	M590. 3 x 9-speed
Front Derailleur	Shimano Deore	M591. Traditional style dual pull. 28.6mm clamp
Rear Derailleur	Shimano Deore	M591 SGS. Top-normal traditional
Cog or Cogset	Shimano HG-61	11-34t
Stem	Kalloy, AS-008	25.4mm bar clamp. Aluminum. 4-bolt face. Black
Handlebar	Salsa MotoAce	660mm wide. 17°. Black
Saddle	WTB SST Comp	Steel rails. Black vinyl. Feels pretty o.k.
Seatpost	Kalloy SP-342	27.2mm. 350mm. Black
Chain	SRAM PC-971	9-speed
Extras		Surly stainless steel post clamp. 14g DT Swiss spokes

Standard one-leg kickstand included. More cargo accessories are available from Xtracycle. Visit them at Xtracycle.com  
 Fork steer tubes are uncut. Pedals not included. Specifications sometimes change. Cope.

# 1X1 FRAME

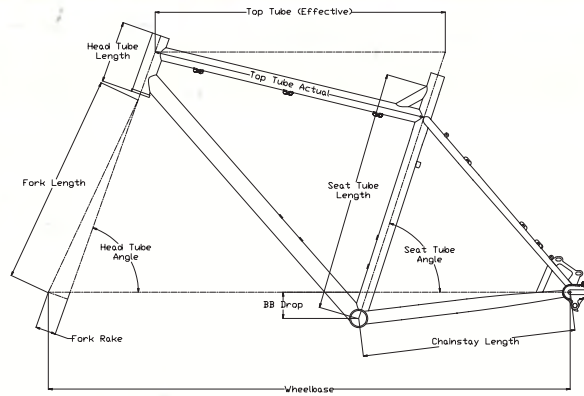

## FRAME GEOMETRY

Size	ST (C-T)		TT (C-C)*		TT (Effective)		HT Angle		ST Angle		BB Drop		CS Length	
	inches	mm	inches	mm	inches	mm	degrees	degrees	inches	mm	inches	mm	inches	mm
xSmall	14.0	355.6	20.9	532.0	21.5	546.0	71.0	73.0	1.6	40.0	16.5	419.0		
xSmall	16.0	406.4	21.6	549.0	22.5	571.0	71.0	73.0	1.6	40.0	16.5	419.0		
Medium	18.0	457.5	22.4	570.0	23.5	596.0	71.0	73.0	1.6	40.0	16.5	419.0		
Large	20.0	508.8	23.2	590.0	24.3	616.0	71.0	73.0	1.6	40.0	16.5	419.0		
xLarge	22.0	558.8	23.9	608.3	24.8	631.0	71.0	73.0	1.6	40.0	16.5	419.0		

Size	Wheel Base		S.O. Height**		HT Length		FK Length		FK Rake	
	inches	mm	inches	mm	inches	mm	inches	mm	inches	mm
xSmall	39.8	1011.9	28.2	717.0	3.5	90.0	17.8	453.0	1.6	40.0
Small	40.8	1037.3	29.3	745.0	3.9	100.0	17.8	453.0	1.6	40.0
Medium	41.8	1062.6	30.5	774.0	4.3	110.0	17.8	453.0	1.6	40.0
Large	42.6	1083.2	31.7	804.0	4.9	125.0	17.8	453.0	1.6	40.0
xLarge	43.3	1098.8	33.0	838.0	5.7	145.0	17.8	453.0	1.6	40.0

\* All dimensions are preliminary and are subject to change.  
 \*\*Measurements use tire with a diameter of 676mm taken from middle of the toptube to level ground.

## FRAME SPECIFICATIONS

- Tubing:** 4130 CroMoly steel. Main triangle double-butted. TIG-welded
- Rear dropouts:** Investment cast Surly track dropouts, 135mm spaced
- Braze-ons:** 51mm disc tabs and removable cantilever bosses front and rear, rear brake toptube housing stops, seatstay mounted disc housing guides, fender eyelets front and rear and dual water bottle mounts
- Seatpost diameter:** 27.2mm
- Seatpost clamp:** 30.0mm Surly stainless, included
- Headset:** 1-1/8" threadless
- Bottom bracket shell:** 73mm wide, threaded English 1.37" x 24t
- Tire clearance:** Room
- Fork:** Suspension corrected for 100mm travel suspension fork. 100% CroMoly
- Color:** Cash Black

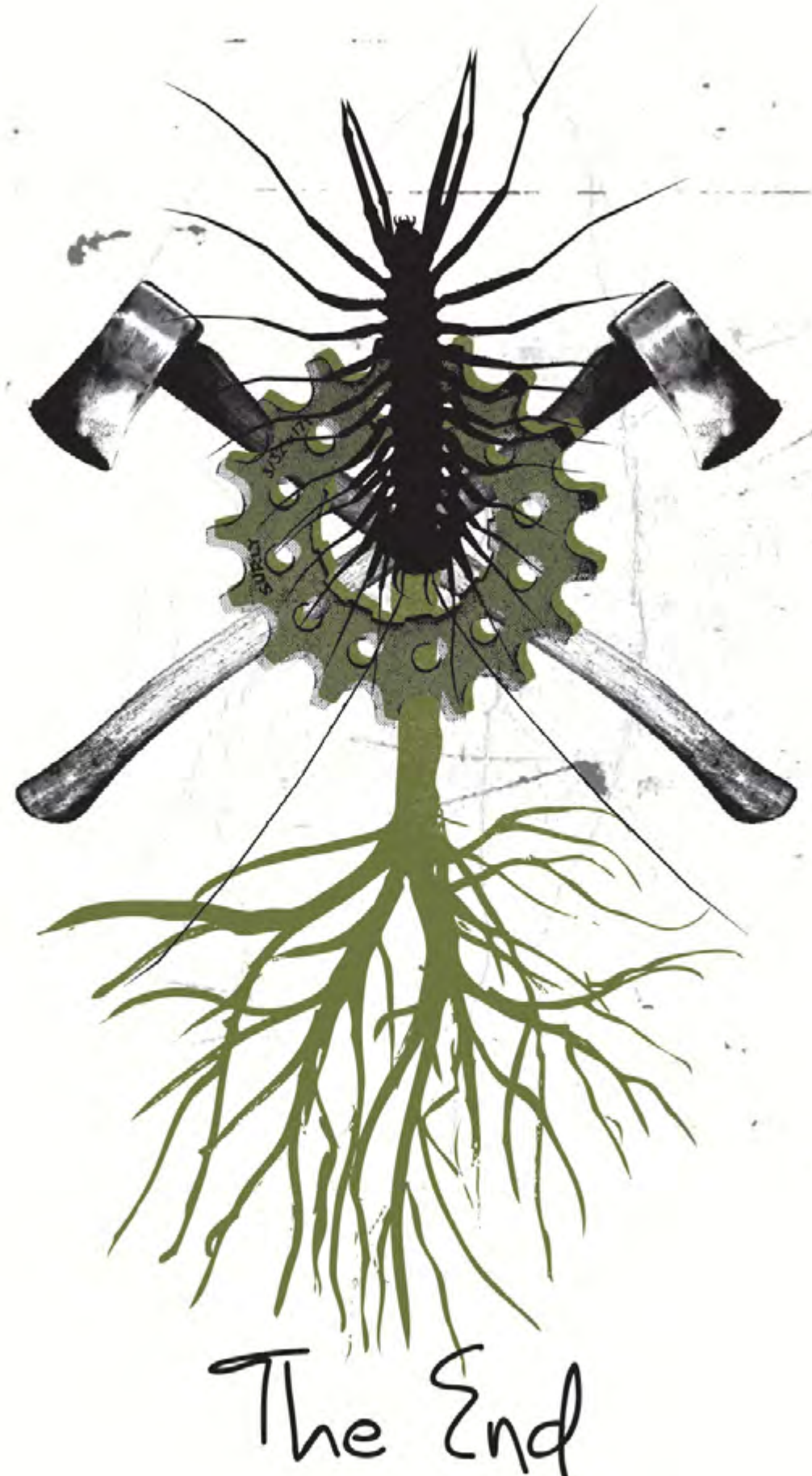

**SURLY**

**6400 W. 105th St.  
Bloomington, MN 55438**

Phone: 877.743.3191

Web: [www.surlybikes.com](http://www.surlybikes.com)

E-mail: [derby@surlybikes.com](mailto:derby@surlybikes.com)



**VOLUME 1**