

SURLY®

2004



NEW Long Haul Trucker™ Frameset

In an age of 'epic' this and 'extreme' that, when it seems everything is new and improved, bigger, better, & faster, it might seem antithetic for us to build—or for you to buy—a touring frame. Didn't those die off with the other dinosaurs of the 70's?

Truth is, there is little as epic as a really long bike ride. It resets your mind. It challenges your body and spirit. It stirs and purges, soothes and recharges. 'The daily grind' becomes meaningful. Just you, and everything you need to live, packed up on your bike.



So where do you want to go? To work and back everyday? A week long trip to the next state over? Or perhaps La Paz, Bolivia, via Homer, Alaska. Maybe you just want to wake up and wonder where you are. The Surly® Long Haul Trucker is the right tool for the job. It's not flashy and it's not made of the latest, lightest, thinnest alloy. It is made, like all our frames, of cro-moly steel. Why? Because steel is tough and durable, yet resilient. It soaks up the rough stuff, but remains stiff enough to provide an efficient ride. Sure, aluminum can be tough and carbon fiber can soak up road static. Heck, titanium even acts a lot like steel. But there is nothing else that does all the things that steel does for so little money.

What did we do with steel on this frameset? We designed the geometry for all day, everyday comfort, even fully loaded (quite different from the vast majority of frames out there). Long chain stays and a laid back head angle provide a comfy platform for day after day after day in the saddle. It's got 3 sets of water bottle cage bosses. It's got braze-ons for carrying a couple of extra spokes. It's got braze-ons for front and rear racks. The head tube is taller on top to help put you in a more upright position and save strain on your neck, back, shoulders, wrists and elbows. The bigger sizes take 700c wheels, while the smaller frames are designed for 26" wheels so they fit without toe overlap or compromised handling.

Like all Surlys, it sports practical, standard sizing for things like seatpost, front derailleur, and stem. It even sports downtube shifter braze-ons. All this means you can easily find new parts for it or use stuff you already have.

The Long Haul Trucker isn't the bike that everyone is going to have. It isn't the next big thing. It won't race like a champ or scream down rocky singletrack. It isn't about impressing your friends. It's a tool for finding out what you are capable of inside. Are you ready to ride?

Size	ST (C-T)		TT (C-C)*		TT (Effec.)	HT Angle	ST Angle	BB Drop		CS Length	
	inches	mm	inches	mm				inches	mm	inches	mm
42 cm	16.5	420.0	19.4	492.6	19.9	70.0	75.0	1.9	47.0	18.1	460.0
46 cm	18.1	460.0	20.0	508.3	20.3	70.0	74.5	1.9	47.0	18.1	460.0
50 cm	19.7	500.0	20.7	525.0	20.9	71.0	74.0	1.9	47.0	18.1	460.0
52 cm	20.5	520.0	21.1	534.8	21.3	71.0	73.5	1.9	47.0	18.1	460.0
54 cm	21.3	540.0	21.6	549.6	21.9	71.0	73.0	1.9	47.0	18.1	460.0
56 cm	22.0	560.0	22.2	564.4	22.4	72.0	73.0	3.1	78.0	18.1	460.0
58 cm	22.8	580.0	22.8	580.1	23.1	72.0	72.5	3.1	78.0	18.1	460.0
60 cm	23.6	600.0	23.4	594.6	23.6	72.0	72.5	3.1	78.0	18.1	460.0
62 cm	24.4	620.0	23.8	603.7	24.0	72.0	72.0	3.1	78.0	18.1	460.0

*Center to Center top tube is preliminary and final lengths are subject to change.

Long Haul Trucker Specifications:

Tubing: 100% Surly 4130 cro-moly steel, main triangle double-butted

Rear dropouts: Vertical, 135mm

Brake compatibility: Linear pull or cantilever

Braze-ons: Upper bosses and dropout eyelets for racks front and rear; fender eyelets; chainstay spare spoke holder; pump peg; downtube lever bosses; 3 sets of H₂O cage bosses; rear housing stop for canti brakes; housing stops for brakes and derailleurs

Seatpost diameter: 27.2mm

Seatpost clamp diameter: 30mm. Surly Constrictor™ included

Headset: 1-1/8" threadless

Front Derailleur Clamp Diameter: 28.6mm

Bottom bracket shell: 68mm wide, 1.37 x 24t

Chainring clearance: 42/53t double, 38/52/56t triple

Fork: 4130 cro-moly, lugged and brazed, tapered curved blade w/ lowrider rack eyelet

Sizes available: 42cm, 46cm, 50-62cm even sizes

Color: Sage Green

Weight: 58cm frame = 5.15 lbs. (2.34 kg) Fork - uncut = 2.25 lbs. (1.02 kg)

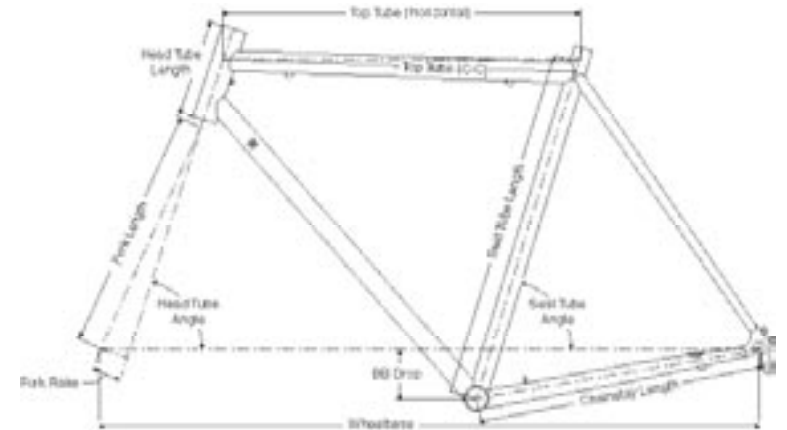

Size	Wheel Size 26"		Wheel Base 700c		S.O. Height**		HT Length		FK Length		FK Rake	
	inches	mm	inches	mm	inches	mm	inches	mm	inches	mm	inches	mm
42 cm	x		40.8	1036.6	27.7	703.0	4.4	110.7	14.8	376.0	1.8	45.0
46 cm	x		41.1	1042.7	28.5	723.8	4.6	116.7	14.8	376.0	1.8	45.0
50 cm	x		41.2	1046.8	29.8	756.9	5.7	144.0	14.8	376.0	1.8	45.0
52 cm	x		41.5	1053.1	30.5	775.1	6.4	163.0	14.8	376.0	1.8	45.0
54 cm	x		41.9	1064.0	31.2	793.1	7.2	182.0	14.8	376.0	1.8	45.0
56 cm		x	41.6	1055.7	32.0	812.2	6.0	152.0	15.4	390.0	1.8	45.0
58 cm		x	42.0	1066.7	32.7	830.0	6.7	171.0	15.4	390.0	1.8	45.0
60 cm		x	42.6	1080.8	33.5	849.7	7.4	189.0	15.4	390.0	1.8	45.0
62 cm		x	42.7	1085.3	34.1	867.3	8.3	210.0	15.4	390.0	1.8	45.0

* Standover height for 26" models is a rough estimate based on preliminary drawings using a Primo Racer 26x1.25 tire that measures 626mm in diameter

** Standover height for 700c models is a rough estimate based on preliminary drawings using a Rivendell (Panaracer) Ruffy Tuffy 700 x 28 (actually closer in size to 700 x 32) tire that measures 690mm in diameter

Karate Monkey™ 29" Frameset

The Karate Monkey is all about big wheels and versatility. Build it up as a 700c mountain bike, cyclocross bike, commuter, or backcountry tourer. Create your ideal Frankenstein.



We decided to produce a 29er because we thought we could make improvements on the current designs from other manufacturers, while offering a unique, quality frameset at a Surly price. Mission accomplished.

Frameset geometry is the key to the handling characteristics of any bike. It doesn't matter how pretty it is, or how many braze-ons it has, if it rides like crap. We want you to use the Karate Monkey on singletrack, as well as fire roads and pavement, so we spent time figuring out the best ways to make our rig handle like a mountain bike...not like a tractor. The most obvious frame component of the Karate Monkey is the curved seat tube. This feature allows us to use shorter chainstays without worrying about the rear tire rubbing on the seat tube when the wheel is jammed all the way forward in the dropouts. Shorter chainstays mean quicker handling and better traction at the rear. Toe overlap is another concern with big-wheeled bikes. We tweaked our measurements to eliminate overlap, while maintaining the riding characteristics of a mountain bike.

Options galore. Single-speed? Sure. Like gears? Use some. The Karate Monkey will accommodate a standard or compact mountain triple up front, and a cassette full o' cogs in the 135mm-spaced rear. Our Surly horizontal dropouts are cast with a derailleur hanger, so you have several drivetrain options. Disc brakes or cantilevers? Once again, it's up to you. The Karate Monkey comes with International Standard disc mounts and removable canti pivots. Rigid or suspended front end? We provide a unicrown, tapered straight blade, suspension-corrected rigid fork. Do as you wish.

Like all Surly frames and forks, the Karate Monkey is built with Surly 4130 cro-moly. The butted tubes are thick enough to withstand a derby circle beating, but thin enough to deliver the fine ride characteristics that steel is known for.

Want a trail-worthy, high roller that won't put you in the poor house?

Check out the Karate Monkey.

Size	ST (C-T)		TT (C-C)		TT (Effec.)		HT Angle degrees	ST Angle degrees	BB Drop		CS Length	
	inches	mm	inches	mm	inches	mm			inches	mm	inches	mm
small	16.0	406.4	21.7	552.0	22.7	576.6	71.0	73.0	2.7	68.0	17.0	431.0
medium	18.0	457.2	22.6	574.5	23.6	600.6	71.5	73.0	2.7	68.0	17.0	431.0
large	20.0	508.0	23.4	594.5	24.3	617.5	72.0	73.0	2.7	68.0	17.0	431.0
x-large	22.0	558.8	24.2	614.3	24.9	633.6	72.0	73.0	2.7	68.0	17.0	431.0

Karate Monkey Specifications:

Tubing: 100% Surly 4130 cro-moly steel. Main triangle double-butted. TIG welded

Rear dropouts: Surly horizontal dropouts with derailleur hanger. 135mm spaced

Brake compatibility: Most International Standard disc or cantilever rim-type

Braze-ons: Cantilever bosses with removable pivots, dual water bottle mounts, down tube shift cable routing, tube guides for hydraulic hose or solid housing on the seatstay, standard cable housing stops on the top tube.

Seatpost diameter: 27.2mm

Seatpost clamp diameter: 30mm. Surly Constrictor included

Headset: 1-1/8" threadless

Front Derailleur Clamp Diameter: 28.6mm

Bottom bracket shell: 73mm wide, 1.37 x 24t

Chaining clearance: 48t max

Fork: Suspension-corrected, tapered straight blade, 4130 cro-moly. International Standard disc mount and removable canti pivots

Sizes available: 16", 18", 20", and 22"

(measured from the center of the bottom bracket to the top of the top tube)

Color: Camp Stove Green and Pitch Black

Weight: 18" frame = 5.73 lbs. (2.6 kg)

Fork - uncut = 2.59 lbs. (1.18 kg)

Geometry:

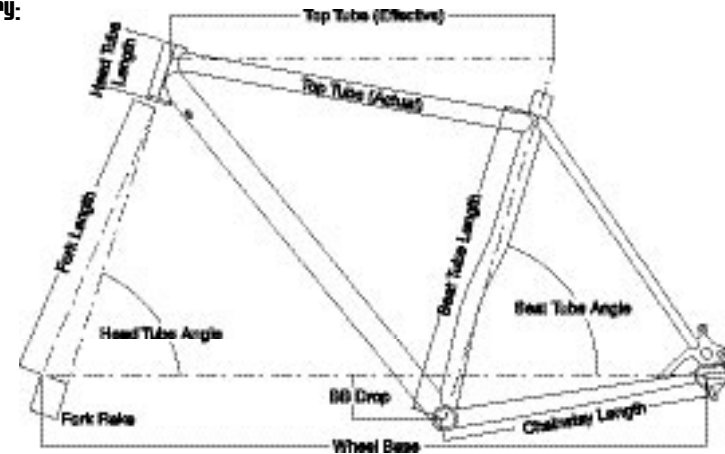

Size	Wheel Base		Front-Center		S.O. Height**		HT Length		FK Length		FK Rake	
	inches	mm	inches	mm	inches	mm	inches	mm	inches	mm	inches	mm
small	41.1	1044.9	24.5	623.0	30.8	781.6	3.1	80.0	18.4	468.0	1.7	43.0
medium	41.9	1064.0	25.3	642.0	31.9	811.1	3.5	90.0	18.4	468.0	1.7	43.0
large	42.4	1076.1	25.7	654.0	33.0	838.2	3.7	95.0	18.4	468.0	1.7	43.0
x-large	43.0	1092.1	26.4	670.0	34.1	866.8	4.1	105.0	18.4	468.0	1.7	43.0

** Standover height is based on a 29 x 2.1" tire that measured 737mm in diameter

Pacer™ Frameset

We noticed that the availability of affordable steel road bike framesets had diminished substantially over the last few years. So, we decided to do something about it. Meet the Pacer....Surly's all-day road rig.

What makes a bike an all-day bike? Comfort and reliability. Rides like a bike. It's predictable. The Pacer's conservative geometry and tubing spec lend themselves to a full day in the saddle. Of course, it's equally suitable for those short rides to your favorite watering hole. The 4130 TIG-welded frame and brazed fork are designed to take the edge off the bumps and cracks in the road, but remain laterally stiff for those out-of-the-saddle sprints and climbs.

Though vertical compliance is definitely a goal when designing a new frame, tire clearance is just as important. The casings of your tires flex before your frame and fork do, and wide tires generally flex more than narrow ones, giving you a softer ride. Wide tires can be faster than skinnies on a lot of surfaces that you will encounter on your rig. So, the Pacer was designed to accept 700x28c tires with fenders or 700x32c tires without...while allowing you to use standard-reach or short-reach road caliper brakes.

The Pacer is spec'd with a 1-1/8" threadless fork because of the wide selection of headsets and stems available to accommodate it. Like most Surly frames, this one uses commonly available components: 27.2mm seatpost, 68mm bottom bracket, 130mm rear hub... basically, items that you might have lying around, waiting for a chance to be used. We recommend using standard-reach brakes, but some short-reach fit also.

The durability and versatility of the Pacer make it an ideal commuter, day-tripper, and vehicle for exploration. The frame is offered in 9 sizes (42-62cm), so there should be a Pacer that fits you. You won't be disappointed.



Pacer Specifications:

- Tubing:** 100% Surly 4130 cro-moly steel. Main triangle double-butted. TIG welded
- Rear dropouts:** Vertical Breeze-In dropouts, 130mm spacing
- Braze-ons:** Single fender eyelets front and rear, dual water bottle mounts, and pump peg (54cm and larger)
- Seatpost diameter:** 27.2mm
- Seatpost clamp diameter:** 30.0mm Surly Constrictor included
- Headset:** 1-1/8" threadless.
- Front Derailleur Clamp Diameter:** 28.6mm
- Bottom bracket shell:** 68mm wide, threaded English 1.37x24t
- Tire clearance:** Room for 700x32c or 700x28c with fenders
- Color:** Midnight Black
- Weight:** 56cm = 4.57 lbs. (2.07 kg) Fork - uncut = 2.17 lbs. (.98 kg)

Geometry:

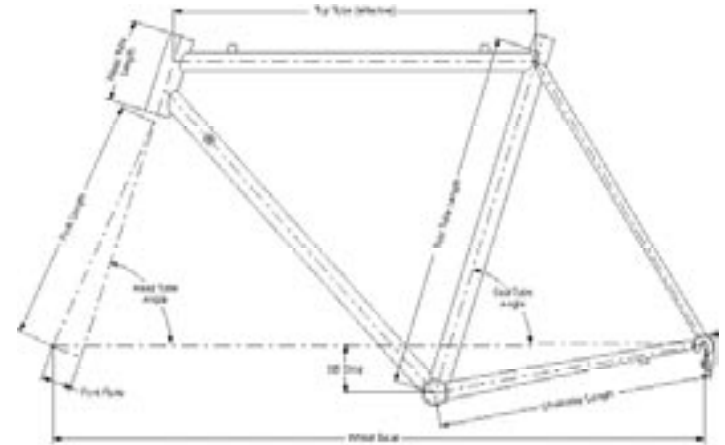

Size	ST (C-T)		TT (C-C)		TT (Effec.)		HT Angle degrees	ST Angle degrees	BB Drop		CS Length	
	inches	mm	inches	mm	inches	mm			inches	mm	inches	mm
42 cm	16.5	420.0	19.4	491.5	20.0	507.0	71.5	75.5	2.8	72.0	16.1	410.0
46 cm	18.1	460.0	19.9	504.2	20.3	515.0	71.5	75.0	2.8	72.0	16.1	410.0
50 cm	19.7	500.0	20.7	526.4	20.9	530.0	72.0	74.5	2.8	72.0	16.1	410.0
52 cm	20.5	520.0	21.3	540.0	21.3	540.0	72.5	74.0	2.8	72.0	16.1	410.0
54 cm	21.3	540.0	21.7	550.0	21.7	550.0	72.5	73.5	2.8	72.0	16.3	415.0
56 cm	22.0	560.0	22.2	565.0	22.2	565.0	73.0	73.0	2.8	72.0	16.3	415.0
58 cm	22.8	580.0	22.8	580.0	22.8	580.0	73.5	73.0	2.8	72.0	16.3	415.0
60 cm	23.6	600.0	23.2	590.0	23.2	590.0	73.5	72.5	2.8	72.0	16.3	415.0
62 cm	24.4	620.0	23.8	605.0	23.8	605.0	74.0	72.5	2.8	72.0	16.3	415.0

Frame geometry subject to change

Size	Wheel Base		S.O. Height**		HT Length		FK Length		FK Rake	
	inches	mm	inches	mm	inches	mm	inches	mm	inches	mm
42 cm	38.4	974.4	28.2	715.3	3.3	84.0	14.8	376.0	2.0	50.0
46 cm	38.5	979.0	28.9	735.2	3.9	99.0	14.8	376.0	2.0	50.0
50 cm	38.8	985.6	29.8	756.1	3.9	99.0	14.8	376.0	2.0	50.0
52 cm	38.9	987.2	30.2	767.9	4.1	104.0	14.8	376.0	2.0	50.0
54 cm	39.1	992.8	30.9	785.7	4.7	119.0	14.8	376.0	1.8	45.0
56 cm	39.3	998.8	31.6	803.5	5.4	136.0	14.8	376.0	1.8	45.0
58 cm	39.7	1009.2	32.4	822.7	6.1	154.0	14.8	376.0	1.8	45.0
60 cm	39.9	1013.7	33.1	840.2	6.7	171.0	14.8	376.0	1.8	45.0
62 cm	40.3	1023.4	33.8	859.3	7.4	189.0	14.8	376.0	1.8	45.0

** Standover height is based on a 700 x 25c Michelin Axial Pro tire that measured 680mm in diameter

Instigator™ Frame

The **Instigator**. While we really don't want to tell you what you can or can't do with the multi-purpose Instigator, consider "urban assault vehicle", "jumper", "freerider", "dual-slammer", or "wall art." We haven't just slapped a bunch of gussets on a mountain bike to achieve the desired aesthetic. We have tried to correct some of the glaring mistakes found in other bikes of this genre, incorporating some standard and unique Surly features at the same time. We're sure the result of our efforts will have you riding "over your head" in no time.



What's so special about the Instigator?

100% Surly 4130 double-butted cro-moly steel construction

Know anything about vinyl LPs? Manufactured correctly, they produce a higher-quality analog sound, cost more to produce than CDs, yet typically cost less to buy. Likewise, nowadays, it costs more to make a production bike out of cro-moly steel than it does out of name-brand aluminum. We do it not because we dislike aluminum (or CDs), but because we strongly believe in steel's superior physical and spiritual properties, not to mention the advantages its use lends to this particular design. Technical spew aside, you'll find the Instigator extremely stiff yet comfortable, and of the same extreme strength you'll find in BMX jumping bikes, 99% of which are still made out of steel. Strangely, we're one of the few companies making a bike like this out of the good stuff. And yes, that's a 1.5" diameter double-butted down tube!

Thick CNC-machined 4130 disk-compatible dropouts

Each one of these beauties is hogged out of a giant block of 4130 cro-moly billet. They are very thick, very strong and very flex-free, as any dropout securing a wheel and brake caliper down 11 flights of stairs should be. Should you choose the disk brake option, the cantilever studs can be removed to save 22 grams and give that sexy, finished look.

ICGS (International Chain Guide Standard) mounts

Chainguide toughguys Mr.Dirt™ and MRP™ got their heads together to develop a chainguide mounting standard that is simple, straightforward, and keeps everything in place without weird little set screws or drilling holes in down tubes. How could we not get behind a great idea whose time has come?? It's there if you need it, doesn't interfere with front derailleur positioning (if you go that route) and it works great. You're ahead of this game on an Instigator.

Junk Saver™ top tube

If you simply adjust conventional rigid mountain bike geometry to ride well with 100-130mm suspension forks, the front end of the bike is raised so high that when you get a size that fits you, you have little or no standover clearance. We like as much clearance as possible on a bike like this, but not at the expense of proper fit. With the Instigator's Junk Saver top tube design, you get the best of all worlds – the travel, the right fit, and the clearance you need to clean tricky maneuvers and keep those "important packages" safe.

FFF™ chainstays

It's awfully silly that a rigid bike with big-travel up front wouldn't provide clearance for a big shock-absorbing tire out back. Not everyone wants to run giant tires but the option should always be yours, especially on a bike like the Instigator. Custom-designed Fatties Fit Fine chainstays are standard equipment on all Surly bikes, and, in this case will fit the enormous 26x2.35" Tioga® Factory DH™ with no problem, or even the Intense® 26x2.7" on a 30mm rim. If you run disk brakes, 24x3.0" tires fit, providing the ultimate moto experience.

Gusseted and reinforced front end

Ahh, the ubiquitous gusseted front end. Ya gotta have it and it looks cool. Ours features an extra-thick headtube with machined-in reinforcing ring, a downtube gusset, and two beefy side plates to get the job done right. A 5" travel suspension fork is a pretty long lever.

We offer The Instigator in four sizes, which should cover most of you.

It goes without saying that the Instigator frame isn't light – 6.4lbs. for the 16" and 6.6lbs for the 18" size – but not bad for a bike like this. Expect complete bikes to weigh 27-40 lbs, depending on your component selection and particular need of beefiness.

Buy an Instigator and put yourself in a precarious riding situation today.

Instigator Specifications:

Tubing: 100% Surly 4130 cro-moly steel. Main triangle double-butted. TIG welded
Rear dropouts: Proprietary Surly 4130 billet. Spaced 135mm
Brake compatibility: International Standard disk or Cantilever rim-type
Braze-ons: Removable cantilever bosses, dual water-bottle mounts, Down tube shift cable shorting, tube guides for hydraulic hose or solid housing, ICGS Chainguide mount
Seatpost diameter: 29.4mm
Seatpost clamp diameter: 31.8mm (1-1/4") Surly Constrictor included
Headset: 1-1/8" threadless
Front derailleur size: 31.8mm (1-1/4") bottom pull
Bottom bracket shell: 73mm wide, threaded English 1.37x24t
Chainring clearance: 48t max
Fork compatibility: Geometry is designed around a 100 or 130mm suspension fork. Using shorter or longer forks will compromise intended ride characteristics, i.e. less BB clearance, faster or slower handling, etc.
Color: Jet Black and Hot Do
Weight: 18" = 6.61 lbs. (±)

Geometry:

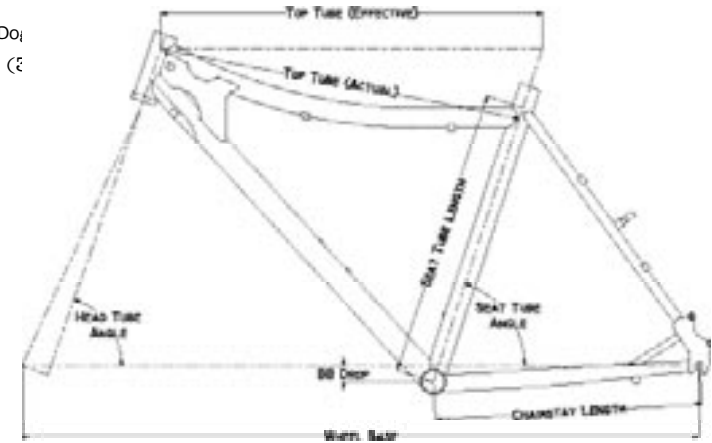

Size	ST (C-T)		TT (C-C)		TT (Effec.)		HT Angle degrees	ST Angle degrees	BB Drop		CS Length	
	inches	mm	inches	mm	inches	mm			inches	mm	inches	mm
x-small	14.0	355.6	21.0	533.5	22.0	558.8	71.0	72.0	0.9	24.0	16.7	425.0
small	16.0	406.4	21.5	546.6	22.6	573.9	71.0	72.0	1.0	25.0	16.7	425.0
medium	18.0	457.2	22.6	574.4	23.6	599.3	71.0	72.0	1.0	25.0	16.7	425.0
large	20.0	508.0	23.8	604.1	24.6	624.4	71.0	72.0	1.0	25.0	16.7	425.0
	Wheel Base**		S.O. Height*		HT Length		FK Length		FK Rake			
	inches	mm	inches	mm	inches	mm	inches	mm	inches	mm		
x-small	41.1	1044.3	28.0	711.9	4.3	110.0	N/A	N/A	N/A	N/A		
small	41.2	1045.3	29.0	737.1	4.3	110.0	N/A	N/A	N/A	N/A		
medium	41.9	1064.7	30.4	773.0	4.3	110.0	N/A	N/A	N/A	N/A		
large	43.1	1096.0	32.0	813.7	5.1	130.0	N/A	N/A	N/A	N/A		

*Measurement taken using tire diameter of 676 mm (Tioga 2.1 DH), will vary with tire choice
 **Measurement taken using Marzocchi Z1 w/ 100mm travel, will vary with fork choice
 N/A = Frame sold sans fork.

Our
Complete Bike!

Cross-Check™



A cyclocross bike by category, the Cross-Check has proven itself over and over in the real world, on the streets, in the dirt, through muck and sleet, blazing sun and dark of night, over exhilarating trails, through hectic traffic and long stretches of uninterrupted back road boredom. Are we serious? Absolutely. People have written us time and again telling us how they use it as their commuter, their around-towner, their touring bike; and each time, invariably, they compliment its handling, comfort, and durability (so happy, they seem to forget how affordable it was).

Out of the box, it's a study in value. We carefully selected components that were light enough to make riding it enjoyable, but not stupid-light. Sometimes, with other bikes, durability overshadows comfort and ease of use. Not the Cross-Check. Wide bar, cyclocross style bar-end shifters, a comfy saddle, enough gears to handle any terrain, and of course the 4130 cro-moly frame and fork simply beg to be ridden. And ride you will. You'll be knocked out by its handling, the way it carves a corner and sucks up road static. It's responsive when you turn the bar or stomp on the pedals, but it's predictable, not whippy.

The way we set it up, you may never change a thing about it. But if you're like us, you'll start to tinker, and this is the bike for that. We began with common sizing for things like seatpost, front derailleur clamp, stem, and headset. We gave it eyelets so you can add a rack or fenders. Then we added some smooov Surly touches. Our Gnot-rite™ rear spacing accepts road or mountain hubs. The brake pivots come sporting traditional cantilevers, but it takes linear pull brakes just as easily. The rear dropouts are semi-horizontal with long slots, so you can rock it out as a single speed. Big rings? Fat tires? Add our Fixxer™ and run it as a fixed gear? Yes, yes, oh lord, yes. What won't it do? Drain your wallet of every last penny, that's what.

Think of the Cross-Check like an army jeep: tough as nails and used for everything. Perhaps because of its utilitarian qualities, it has a special kind of kung fu, a balance of value and versatility we think you'll appreciate. It isn't the result of market research, nor did we just stumble onto something. We ride bikes. We love bikes. This is a work of devotion.

It is deliberate. A machine which animates personal freedom. And we think that's beautiful.

Tubing: 100% Surly 4130 cro-moly steel. Main triangle double-buttet. TIG welded.

Rear dropouts: Long horizontal dropouts with adjusters feature single-speed compatibility, wheelbase adjustability and our exclusive Gnot-rite 132.5mm spacing to easily fit 130mm road or 135mm MTB hubs, should you want to switch wheels between bikes and whatnot.

Chainring clearance: Though we haven't tried a '56', we manipulated the chainstays heavily so you can fit whatever size rings you want, so go for it!

Downtube cable routing: Simply put, top-tube routed shifter cables aren't any better, and they look crummy. Our downtube routed cables look clean, and don't promote water dribblin' down the rear derailleur cable.

We could go on and on, but we'll get to the point: The Cross-Check is a sweet bike that is affordable, fun to ride, and built to last a long time. Once a competent, independent bicycle dealer assembles and preps your bike, you'll be trail bound and unable to wipe the grin off your face. Let us know how it goes...

Cross-Check Geometry:

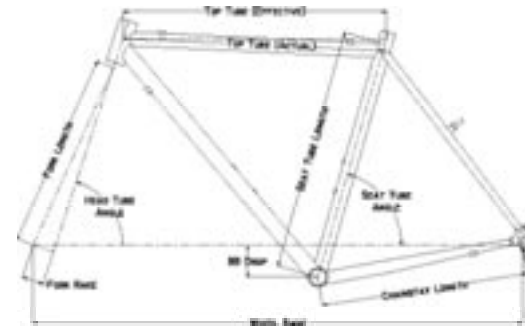

See next page for a complete Cross-Check frame geometry grid.

Component Sizing:

Size	Stem Length Inches mm	Stem Angle** degrees	Hbar Width Inches mm	Crank Length Inches mm
42 cm	2.0 50.0	84.0	15.7 400.0	6.7 170.0
46 cm	3.1 80.0	84.0	15.7 400.0	6.7 170.0
50 cm	3.1 80.0	84.0	16.5 420.0	6.7 170.0
52 cm	4.1 105.0	96.0	16.5 420.0	6.7 170.0
54 cm	4.1 105.0	96.0	17.3 440.0	6.9 175.0
56 cm	4.1 105.0	96.0	17.3 440.0	6.9 175.0
58 cm	4.7 120.0	96.0	17.3 440.0	6.9 175.0
60 cm	4.7 120.0	96.0	18.1 460.0	6.9 175.0
62 cm	- -	- -	- -	- -

** Stems can be flip-flopped to customize angle.

Bike Specifications:

Component	Type	Description
Frame	Surly Cross-Check	100% Surly 4130 cro-moly steel. Main triangle double-buttet. TIG welded. Rear rack bosses. Blood Red.
Fork	Surly Cross-Check	100% cro-moly, lugged + brazed crown. 1-1/8" threadless steerer. Blood Red
Headset	Ritchey Logic Comp	1-1/8" threadless, w/ 15mm spacers. Black.
Stem	Tahoma	1-1/8" threadless. Forged. Black.
Handlebars	Salsa Moto Ace Bell-Lap	26.0mm clamp diameter. Black.
Handlebar Wrap	Co-Union Cork Mix	Feels good. Black.
Brake Levers	Shimano	#BL-R400 aero.
Brakes	Tektro Cantilevers	#862A. Silver.
Cable Hanger, front	Tektro	#1271A. Includes routing noodle. Black.
Cable Hanger, rear	Dia-Compe	#1266. Silver.
Shift Levers	Shimano Bar-end type	#SL-BS77. 9-speed.
Shift Cable Adjusters	Jagwire	#CC-233 Microadjuster.
Front Derailleur	Shimano Tiagra	#FD-4400 Double.
Rear Derailleur	Shimano Tiagra	#RD-4400-GS Mid-cage.
Crankarms	Cyclone	110mm BCD. Silver.
Chainrings	Salsa	36 x 48t.
Pedals	NOT INCLUDED	NOT INCLUDED
Bottom Bracket	Shimano Deore LX	#BB-UN53 68x113mm.
Seatpost	Kalloy Uno	27.2x250mm. Black.
Seatpost Clamp	Surly Constrictor	Black.
Saddle	Velo Endzone	Steel rails, vinyl cover. Black.
Cassette	Shimano Tiagra	#HG-50 9-speed 12-13-14-15-17-19-21-23-25T.
Chain	Shimano HG-72	9-speed compatible.
Hubs	Shimano Deore	#HU-M510. 32 hole. 100mm O.L.D. front, 135mm O.L.D. rear. Black.
Spokes	Stainless Steel	DT Swiss Straight-gauge 14 w/ brass nipples.
Rims	Alex	#AL-DV15. 32 hole x 700c. Silver.
Tires	Ritchey SpeedMax Cross	700x32c. Wire bead. Black wall.
Tubes	Cheng Shin	Standard presta valve 700x32c.

Extras: Clear chainstay protector. Die-extruded cables with anti-rattle donuts. Full CPSC reflector kit. Generic owner's manual

Cross-Check™ Frameset

The Cross-Check has been good to us. No secret why. It's because it's been good to you. Why do people like it so much? Well for starters, it's steel. Steel rides like nothing else (when was the last time you saw a spring made of aluminum?), takes a lot of crap, and doesn't cost an arm and a leg. Then we threw down some crazy-good ideas, like semi-horizontal dropouts with a derailleur hanger, our FFF stays so you can run big, fat tires (even with fenders), long-popular measurements for things like front derailleur clamp and seatpost, and our Gnot-Rite rear spacing that takes mountain and road hubs.



What does all this mean to you? Options, kid, that's what. Get yer freak on. Gears? Great. Single speed? No sweat. Commuter? Touring bike? Grocery getter? Bring it on. Or build it as a bonafide 'cross bike and race it. It likes it.

Best of all, it's actually affordable. You'll need to ask your local shop what they'll charge you, but suffice to say that it is among the most affordable of well-designed, well-built frames around. Whether it's the latest addition to your herd or the only bike you own, the Crosscheck will amaze you with its comfort, versatility and affordability.

Size	ST (C-T)		TT (C-C)		TT (Effec.)		HT Angle	ST Angle	BB Drop		CS Length	
	inches	mm	inches	mm	inches	mm	degrees	degrees	inches	mm	inches	mm
42 cm	16.5	420.0	19.9	505.0	20.6	522.0	72.0	75.0	2.6	66.0	16.5	420.0
46 cm	18.1	460.0	20.3	515.0	20.8	528.8	72.0	74.5	2.6	66.0	16.5	420.0
50 cm	19.7	500.0	21.1	535.0	21.3	541.8	72.0	74.0	2.6	66.0	16.5	420.0
52 cm	20.5	520.0	21.5	545.0	21.5	547.1	72.0	73.5	2.6	66.0	16.5	420.0
54 cm	21.3	540.0	22.0	560.0	22.0	560.0	72.0	73.0	2.6	66.0	16.5	420.0
56 cm	22.0	560.0	22.4	570.0	22.4	570.0	72.0	72.5	2.6	66.0	16.5	420.0
58 cm	22.8	580.0	22.8	580.0	22.8	580.0	72.0	72.5	2.6	66.0	16.5	420.0
60 cm	23.6	600.0	23.6	600.0	23.6	600.0	72.0	72.0	2.6	66.0	16.5	420.0
62 cm	-	-	-	-	-	-	-	-	-	-	-	-

New 62cm frame specs unavailable at this time. Please check surlybikes.com for information.

Cross-Check Specifications:

Tubing: 100% Surly proprietary 4130 cro-moly tubing. TIG welded. Double butted main triangle

Rear dropouts: Semi-horizontal dropouts with adjusters give you single speed compatibility, wheel base adjustability, and our Gnot-rite spacing (132.5mm) allows you to run 130mm road hubs and 135mm MTB hubs

Braze-ons: Bosses front and rear to take cantilever or linear pull brakes, eyelets at the dropouts, rear rack bosses and dual water bottle mounts. Oh yeah, it sports downtube housing stops also.

Seatpost diameter: 27.2mm

Seatpost clamp diameter: 30.0mm (we include our Constrictor clamp with our framesets)

Headset/stem: 1-1/8" threadless

Bottom bracket: 68mm wide, standard English threaded 1.37x24t

Tire clearance: Fatties Fit Fine (FFF) stays and our beautiful slope-crowned custom fork provide room for tires up to 700x45 with mud and fender clearance. For real!

Chaining clearance: Manipulated so you can fit pretty much whatever size rings you want. Go nuts.

Color: Blood Red or Gloss Black

Weight: 56cm = 4.88 lbs. (2.2 kg) Fork - uncut = 2.19 lbs. (.99 kg)

Geometry:

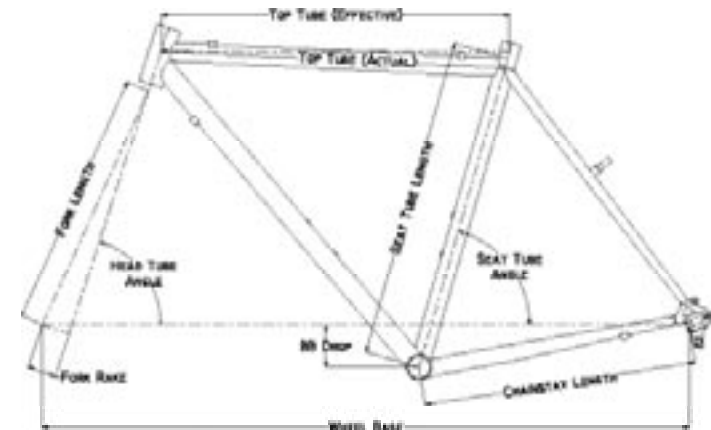

Size	Wheel Base		S.O. Height*		HT Length		FK Length		FK Rake	
	inches	mm	inches	mm	inches	mm	inches	mm	inches	mm
42 cm	39.0	989.9	28.8	731.9	3.6	91.0	15.7	400.0	1.7	44.0
46 cm	39.1	991.9	29.6	750.7	3.6	91.0	15.7	400.0	1.7	44.0
50 cm	39.6	1005.3	30.3	769.4	3.6	91.0	15.7	400.0	1.7	44.0
52 cm	39.6	1006.0	30.6	778.4	3.6	91.0	15.7	400.0	1.7	44.0
54 cm	39.9	1014.4	31.2	793.0	4.0	102.0	15.7	400.0	1.7	44.0
56 cm	40.1	1019.8	31.9	810.7	4.8	121.0	15.7	400.0	1.7	44.0
58 cm	40.6	1030.0	32.7	829.9	5.6	141.0	15.7	400.0	1.7	44.0
60 cm	41.1	1044.8	33.4	847.4	6.3	160.0	15.7	400.0	1.7	44.0
62 cm	-	-	-	-	-	-	-	-	-	-

*Measurements use tire with 685 mm outer diameter (Ritchey™ 700c x 30 SpeedMax™), and taken from middle of top-tube to level ground.

**New 62cm frame specs unavailable at this time. Please check surlybikes.com for information.

Steamroller™ Frameset

A steamroller has the ability to flatten anything in its path, which is exactly how you'll feel the first time you take our Surly Steamroller fixed-gear for a twirl. Unstoppable. Euphoric. Happy. If you haven't ridden 'fixed' before, you might even feel a little bit scared.



It was designed specifically to give you the ideal foundation for a pure and unadulterated fixed-gear bicycle. Some will see the Steamroller and think "messenger", while others will automatically think "track". We hope you'll think about those two, plus "coffee shop", "watering hole", "commuter", "urban assault", "double century" and whatever else. What you do with it is up to you. We can only hope you won't let your preconceived notions about fixed-gear bikes impair your ability to realize the possibilities of the Steamroller frame. The only thing it wasn't designed to do is coast. Although, if you decide to strap a coaster brake out back, we won't spoil your plans. Do what you like, because as with all Surly products, this frameset is merely another platform to expand your horizons and bring your rides to a new or different level of enjoyment.

Since reliable freewheeling technology evolved decades ago, folks have ridden fixed gears by choice, not out of necessity. We won't try to convince you that riding 'fixed' is better or special or why you should try it; you'll have to determine that for yourself. Gee, the Steamroller just might change your life (if this happens please call us)!

The Steamroller geometry, tubing choices and features (or lack thereof) are deliberate in our quest to bring you a balance of pure aesthetics and a ride that is aggressive enough to be quick, exciting and purposeful, yet just mellow enough to be ridden all day long in comfort. We gotta point out the nice fork crown. It's even drilled for a standard-reach safety brake, should you opt for one. The seatstay bridge is drilled for a standard-reach brake as well, though there are no housing stops.

The Steamroller is available in 4 sizes to fit a spectrum of riders, and was designed by fixed-gear riders for fixed-gear riders. We also have some other fine 4130 offerings and neat parts...take a look!

Size	ST (C-T) inches mm	TT (C-O) inches mm	TT (Effec.) inches mm	HT Angle degrees	ST Angle degrees	BB Drop inches mm	CS Length inches mm
49 cm	19.3 490.0	20.7 526.5	20.8 529.5	72.5	74.5	2.8 70.0	15.7 398.0
53 cm	20.9 530.0	21.5 547.0	21.5 547.0	73.0	74.0	2.8 70.0	15.7 398.0
56 cm	22.0 560.0	22.4 568.0	22.4 568.0	73.5	73.5	2.8 70.0	15.7 398.0
59 cm	23.2 590.0	23.1 587.0	23.1 587.0	74.0	73.0	2.8 70.0	15.7 398.0
62 cm	- -	- -	- -	-	-	- -	- -

New 62cm frame specs unavailable at this time. Please check surlybikes.com for information.

Steamroller Specifications:

Tubing: 100% cro-moly steel. Main triangle is double-buttet. TIG welded

Rear dropouts: Investment cast Surly track dropouts, spaced 120mm apart

Braze-ons: None, baby. Pure. OK, we put one set of water-bottle mounts on the seat tube 'cause we're not camels

Seatpost diameter: 27.2mm

Seatpost clamp diameter: 30.0mm Surly Constrictor, included

Headset: 1-1/8" threadless

Bottom bracket shell: 68mm wide, threaded English 1.37x24t

Tire clearance: Proprietary FFF (Fatties Fit Fine) chainstays and our custom fork give room for tires up to 700x38c with fender clearance left over (P.S. - use clip-on fenders!!)

Chaining clearance: Heavy manipulation of the FFF stay gives room for a 50t ring while maintaining chainline. Track crank compatible.

Color: Dave Gray

Weight: 56cm = 4.5 lbs. (2.0 kg) Fork - uncut = 1.87 lbs. (.85 kg)

Geometry:

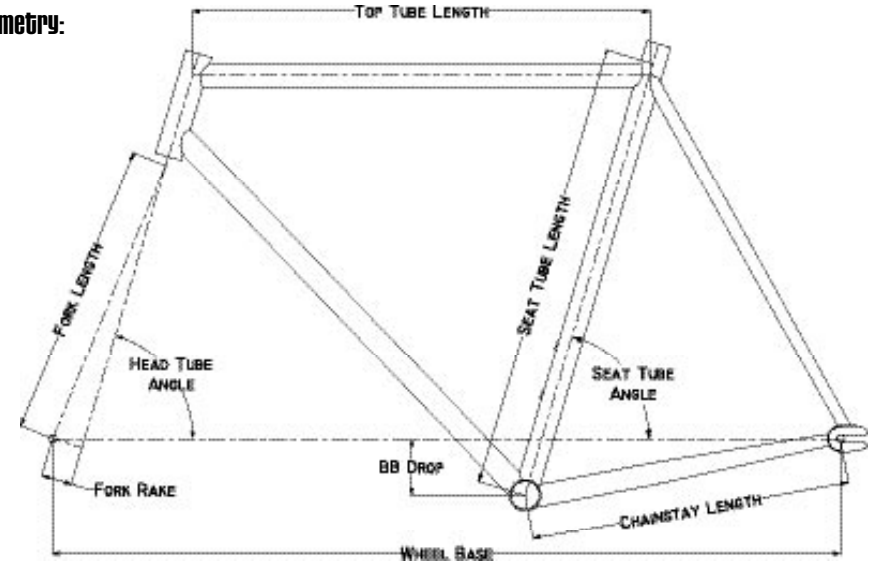

Size	Wheel Base inches mm	S.O. Height* inches mm	HT Length inches mm	FK Length inches mm	FK Rake inches mm
49 cm	38.0 965.7	29.5 748.5	3.1 80.0	14.5 368.0	1.5 38.0
53 cm	38.1 966.6	30.7 780.5	4.2 106.0	14.5 368.0	1.5 38.0
56 cm	38.5 978.6	31.8 807.9	5.2 133.0	14.5 368.0	1.5 38.0
59 cm	38.9 987.6	32.9 835.2	6.3 160.0	14.5 368.0	1.5 38.0
62 cm	- -	- -	- -	- -	- -

* Measurements use tire with outer diameter of 682 (700c x 28), and taken from middle of top-tube to level ground.

** New 62cm frame specs unavailable at this time. Please check surlybikes.com for information.

1x1™ Frameset

Nobody wants to spend a bunch of cash on a single-speed...and why should they? To do so is contrary to the whole spirit of the single-speed experience. At Surly we have known this for years and are continuing to offer our excellent 1x1 single-speed frameset. The 1x1 features a beefy, double-butted 100% cro-moly suspension-corrected frame and 1-1/8" hard fork with very nice black or white powder coating and cool white decals.



The motivations to purchase a 1x1 are endless. Maybe you need a derby-rated steed. Maybe your financial sensibilities have kicked into overdrive at the sight of thick 4130 steel for a price you can justify. Perhaps the wide, curvy stays tempt you to try stuffing in some flat-trackin' skins. Maybe you can't stomach the extra twelve cents per gallon for premium, or maybe you just wanna try something new. Whatever the reason, we're sure you will appreciate the form, function, and value of the 1x1 as much as we do.

How does it ride? Take a look at our detailed geometry chart and you'll see our design is, well, regular. Take the 1x1 for a spin and you'll find that it merely "rides like a bike" – leaving you right at home to forget about the machine and enjoy the ride. The 1x1 rides so nice you won't notice it (you 1x1 owners, who have written, know what we're talkin' about).

The 1x1 is available in x-small, small, medium, large, and x-large sizes. Designed by single-speeders for single-speeders. As with all things Surly, you can't go wrong. Keep lookin' our way for more good deals on tough cro-moly bikes, framesets, and unique components.

1x1 Specifications:

Tubing: 100% cro-moly steel. Main triangle is double-butted. TIG welded

Rear dropouts: Investment cast Surly track dropouts, spaced 135mm apart

Braze-ons: I.S. disc tabs and removable cantilever bosses front and rear, fender eyelets front and rear, and dual water-bottle mounts

Seatpost diameter: 27.2mm

Seatpost clamp diameter: 30.0mm Surly Constrictor, included

Headset: 1-1/8" threadless standard

Bottom bracket shell: 73mm wide, threaded English 1.37x24t

Tire clearance: Proprietary FFF (Fatties Fit Fine) chainstays and our custom fork give room for tires up to 2.7" with plenty of mud and fender clearance left over. Seriously!

Fork: Suspension corrected for 3" travel sus fork. 100% cro-moly

Colors: White or Cash Black

Weight: 18" = 5.0 lbs. (2.3 kg) Fork - uncut = 2.34 lbs. (1.1 kg)

Geometry:

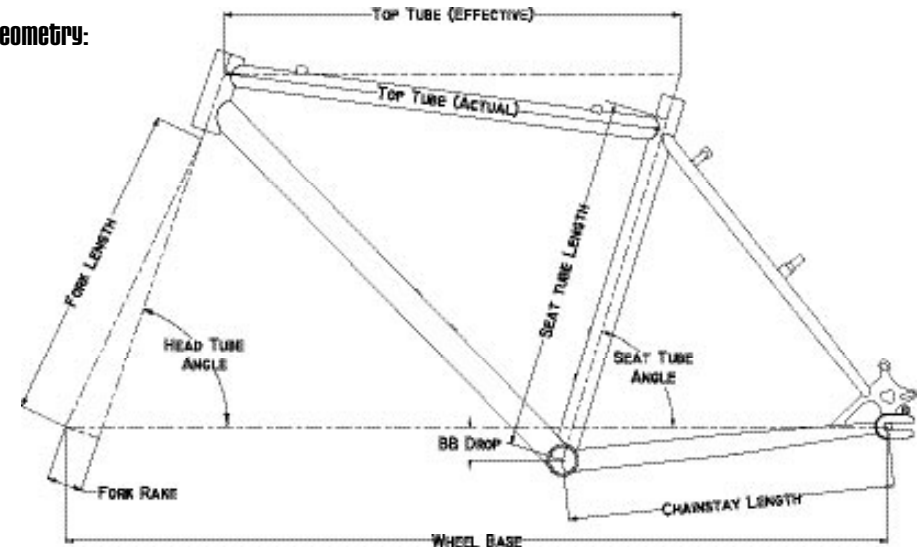

Size	ST (C-T)		TT (C-C)		TT (Effec.)		HT Angle		ST Angle		BB Drop		CS Length	
	inches	mm	inches	mm	inches	mm	degrees	degrees	degrees	degrees	inches	mm	inches	mm
x-small	14.0	355.6	20.5	521.2	21.5	545.0	71.0	73.0	1.7	42.5	1.65	419.0		
small	16.0	406.4	21.3	541.6	22.2	565.0	71.0	73.0	1.7	42.5	1.65	419.0		
medium	18.0	457.2	22.3	565.8	23.0	585.0	71.0	73.0	1.7	42.5	1.65	419.0		
large	20.0	508.0	23.1	586.5	23.6	600.0	71.0	73.0	1.7	42.5	1.65	419.0		
x-large	22.0	558.8	23.9	608.3	24.2	615.0	71.0	73.0	1.7	42.5	1.65	419.0		

Size	Wheel Base		S.O. Height*		HT Length		FK Length		FK Rake	
	inches	mm	inches	mm	inches	mm	inches	mm	inches	mm
x-small	39.9	1013.5	27.7	703.6	3.5	89.0	16.3	413.0	1.8	45.0
small	40.1	1018.5	29.0	736.6	4.0	102.0	16.3	413.0	1.8	45.0
medium	41.5	1053.9	30.2	768.2	4.5	114.0	16.3	413.0	1.8	45.0
large	42.0	1066.5	31.4	797.6	5.3	134.0	16.3	413.0	1.8	45.0
x-large	42.7	1084.9	32.7	830.0	6.3	159.0	16.3	413.0	1.8	45.0

* Measurements use tire with diameter of 676 mm (Toga™ 2.1 DH), and taken from middle of top-tube to level ground.

Forks



Karate Monkey

The Karate Monkey rigid fork replaces suspension forks designed for use on 29"-wheeled bikes. It features International Standard disc mounts, removable canti pivots, 1-1/8" threadless steerer, tapered straight blades, and a black powdercoat finish. 468mm axle to crown.

Rake: 43mm

Steerer: 260mm

Weight: 2.59 lbs. (1.18 kg)



Instigator

The Instigator rigid fork replaces 100mm travel suspension forks. We designed it around the geometry of the Surly Instigator, of course, but it should work just fine for frames with similar geometries. It is constructed of thick-walled, single-butted 4130 cro-moly, so it will hold up under pressure. The fork features International Standard disc mounts, removable canti pivots, 1-1/8" threadless steerer, and a black powdercoat finish. If you want to run fatties in this fork, go ahead. You can easily wedge a 2.7" tire between those straight, tapered (31.8mm to 28.6mm) blades. 447mm axle to crown.

Rake: 43mm

Steerer: 260mm

Weight: 2.76 lbs. (1.25 kg)



1x1

We now have two 1x1 forks to offer. Our new 1x1 fork comes with International Standard disc mounts and removable canti pivots. Otherwise, it's the same fork as our tried-and-true original 1x1 fork...which means you can stuff 2.7" tires between the blades and have room to spare. Both forks are built with 4130 cro-moly tubing, suspension-corrected geometry, 1-1/8" threadless steerers, and black powdercoat. 413mm axle to crown.

Rake: 45mm

Steerer: 260mm

Weight: w/tabs 2.34 lbs. (1.1 kg)



NEW

Long Haul Trucker

Designed as the front end of our Long Haul Trucker touring frame, this fork sports a beautiful investment cast sloping crown and dropouts brazed to curved blades, dual eyelets at the dropouts for fenders and a rack, threaded bosses brazed into the fork blades for mounting a lowrider rack, and cantilever studs which work with canti or linear pull brakes. It has an 1 1/8" threadless steerer, and you have the option of choosing from 2 sizes: 700c (390mm axle to crown) or 26" wheel (376mm axle to crown). Black powdercoat finish.

Rake: 45mm

Steerer: 26" = 260mm

700c = 300mm

Weight: 2.25 lbs (1.02kg)



Pacer

This is the same lugged and brazed fork that we provide with our Pacer road frameset. It will allow you to run 28mm tires with fenders or 32mm tires without. Many standard-reach caliper brakes will work, but we can't guarantee 100% compatibility. Long reach calipers are recommended. This fork comes with single eyelet dropouts, 1-1/8" threadless steerer, and a black powdercoat finish. 372mm axle to crown.

Rake: 45mm

Steerer: 300mm

Weight: 2.17 lbs. (.98 kg)



Steamroller

Our Steamroller fork, designed around our fixed-gear frame, is brazed with a flat crown that is drilled to accept a long reach caliper brake. It has clearance for 700c x 38mm tires. There are no eyelets at the dropouts. 368mm axle to crown. Available with 1" or 1-1/8" threadless steerer. Black powdercoat finish.

Rake: 38mm

Steerer: 300mm

Weight: 1.87 lbs. (.85 kg)



Cross-Check

Our lugged and brazed Cross-Check fork has room for 700cx45mm tires and fenders. We offer it with 1" and 1-1/8" threadless steerers. It features 4130 cro-moly construction, single eyelet dropouts, cantilever brake pivots, and a black powdercoat finish. 400mm axle to crown.

Rake: 44mm

Steerer: 300mm

Weight: 2.19 lbs. (.99 kg)

Surly Profile: Master of Ceremonies

My day begins with a 16-mile ride, winding through Minneapolis and the 'burbs. It takes 45 minutes to 2 hours, depending on the weather and road conditions. That's 1-1/2 to 4 hours away from phones each workday. It's my time to think about my family, my friends, and all facets of cycling. It's also a great time to get some exercise, tune my automatic middle finger extension reflex override function (AMFEROF, for short), and unintentionally improve my riding skills.

I ride Surlys most of the time. Imagine that. My Pacer (set up with time trial bars, a 7-speed drivetrain, fenders, racks, and fat road tires) gets used most, because it best lends itself to my type of commute...lots of pavement, with a few dirt trails thrown in to keep it interesting. I usually ride a 1x1 (one with drum brakes, one with discs, or one with v-brakes and 65mm-wide rims) on the Wednesday Nite Ride, because it has proven itself most worthy of taking the abuse, dished out by the Minneapolis Mafia, week after week. My Instigator (equipped with an Instigator rigid fork and 16-speed drivetrain) is coupled to an Xtracycle (check out www.Xtracycle.com); it's my heavy-duty hauler. My Cross-checks (A mustache-barred 4-speed commuter, an Xtracycled 18-speed, and an S & S-coupled single-speed off-roader) come out when the weather or duty dictates. My Steamroller is in a transitional period, from off-road fixxie to electric-assist freewheeling road rocket. The Karate Monkey, in its third or fourth configuration, is singled with a rear disc and no front brake.



The non-Surly portion of my herd: folding bikes (12", 16", and 20" wheels), 20" and 24" BMX, 20" and 24" muscle bikes, middle-weight and heavy-weight cruisers, English 3-speeds, 26" and 700c tandems, unicycles (20", 24", 26", and 29"), trailers (old tub-style Burley, a B.O.B., and a Bikes At Work 6-footer), mountain bikes and road bikes in many configurations. All my bikes are steel, except for an old Cannondale M800 Beast of the East that I built up as my first single-speed mountain bike in 1995.

What do I do at Surly? I try to keep the Surly crazy train on track. I oversee all areas of Surly: marketing, product design and engineering, quality control, purchasing, customer service, etc. I'm the Jack of All Trades...Master of None. What got me here? Education, perseverance, lots of time in the saddle, lots of time wrenching, and luck.

I work here, because I enjoy the challenge of turning ideas into durable goods. I like working with people who are passionate about cycling technology and cycling culture. I'm still in this industry, after 10 years, because I get to work with my friends. And, if I get stressed out at work, I can always reflect on these simple facts to put things back into perspective: It's just bike stuff. If we make a small design mistake or miss a production deadline, it's not the end of the world. Really, it's not.

Dave Gray

New & Improved!

1x1 Singleator™

Midwest single-speed legend Pete Geigle developed the 1x1 Singleator so you single-speed virgins could taste the pure mountain biking experience without spending too much cash.

Installing horizontal dropouts on your frame can be difficult and/or expensive, particularly if your steed is of the aluminum variety. The Singleator mounts right up to your derailleur hanger and provides a simple, effective, and adjustable means of tensioning the excess chain slack found in vertical dropout single-speed drive trains.

The Singleator features: Triple sealed reversible spring with greater spring tension and wrap capacity, larger cog capacity, chain-rejection protection, fully adjustable chain line, floating tension pulley, and a stainless steel pivot bushing. Stop being so damn serious... get yourself a Singleator, lighten up and give the single lifestyle a try.

New and Improved:

Compatible with both 3/32" and 1/8" chains. Forged aluminum body. 11 tooth pulley wheel. Beware imposters!

Colors: Black or Silver



The 1x1 Speed Gear Chart

1x1	24	26	28	29	30	31	32	34	36
16	1.50	1.63	1.75	1.81	1.88	1.94	2.00	2.13	2.25
17	1.41	1.53	1.65	1.71	1.76	1.82	1.88	2.00	2.12
18	1.34	1.45	1.56	1.61	1.66	1.72	1.78	1.89	2.00
20	1.20	1.30	1.40	1.45	1.50	1.55	1.60	1.70	1.80
22	1.09	1.18	1.27	1.32	1.36	1.41	1.45	1.55	1.64

1x1 Torsion Bar™

Made for us by NITTO®, these wide, flat, 4130 chromoly bruisers will give you a distinct advantage in any derby situation. With a 15° bend, and 24.5" width, they're also mighty comfortable. Get ready to flat track!

Color: Silver



New™ Hubs

Your basic hubs. Sorta like Chuck Taylor high tops for your bike. All are forged aluminum, high flange, and spin on high load, well sealed, adjustable cartridge bearings over solid axles (9x1mm front, 10x1mm rear). It's easy to find replacements should the need arise, or you can swap them out with QR axles if you want. Fronts are spaced 100mm to fit most forks. Fixed-gear rears are spaced 120mm and are ISO threaded on both sides for fixed gear cogs (1.37"x24tpi) and lockrings (1.29"x24tpi LH). 135mm spaced rears are available as dual free-wheel, with threading on both sides for single speed freewheels (1.37"x24tpi), and as fixed/free, with freewheel threading on one side and fixed gear/lockring threading on the other. Black fronts and MTN rears now are available with hollow QR axles. They all come drilled for 32 spokes and are laser etched with the Surly logo.

Color: Black or Silver

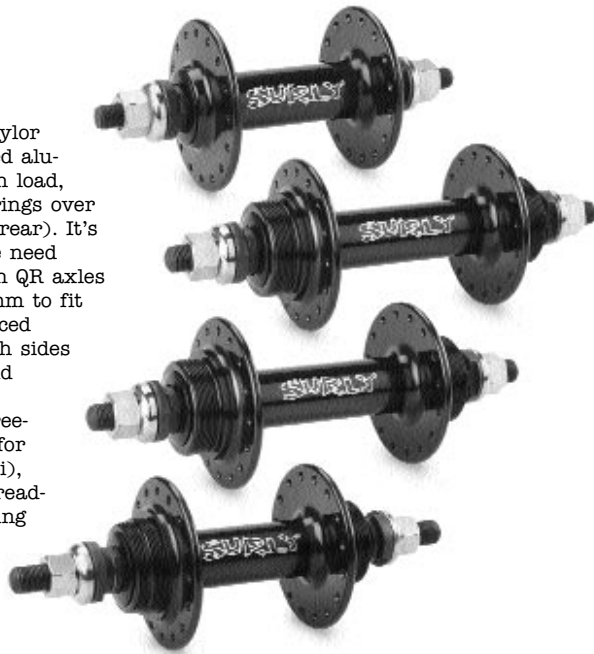

NEW

New™ Disc Hubs

Single speed disc hubs for people like you. Much like our regular New hubs, but with a 6 bolt rotor mount. Fronts spaced 100mm, rears 135mm. Rear is single speed freewheel threaded 1.37"x24tpi. They use the same bearings and axles as the other hubs we offer. Black available with hollow QR axle.

Color: Black or Silver



Fixxer™ Hub Converter

Even if it ain't broke, you can still "fix" it with our Surly Fixxer hub converter. The Fixxer allows you to cheaply and easily convert any Shimano® cassette hub (except Silent Clutch or pre-1997 Dura Ace) into a true fixed-gear. By simply removing the cassette body and replacing it with our adapter, you can use a fixed track cog and lockring for safe coast-free riding. A popular conversion for track racers, Springtime trainers, fixed-gear commuters and messengers, the Fixxer includes all parts necessary for installation, including axle, bearing, cones, spacers, and axle nuts. Most converted hubs can be spaced 120, 126, 130 or 135mm, and can even be used with a freewheel if a freewheeling single-speed conversion is desired.

Color: Silver



NEW

23

Large Marge™ Rim



Our friends, Pat Irwin (Surly-sponsored rider and owner of Pat's Bikes, in Anchorage) and John Evingson (Hydracare rep and custom framebuilder), turned us on to the eclectic world of adventure riding.

It seems there's a need for a super-wide rim for snow bikers, sand bikers, rock crawlers and downhillers who want to run some really big rubber. We decided to make some rims for the same selfish reason we have for making other Surly parts....we want some to use on our own bikes.

We introduce to you...Large Marge. Our double-walled 26" hoop is 65mm wide. It's eyeleted, because a lot of 'em will be laced to disc hubs, and hub brake systems put more stress on spoke holes. Of course, Large Marge is rim brake compatible, if you don't want to use hub brakes. The cross-section profile lends itself to shedding snow and sand, to keep the rotating mass as low as possible. The black ano finish should help to melt off snow that might cling to the rim, and we think it looks cool.

We'll offer Large Marge in a few configurations: 32-hole and 36-hole downhill version, and 32-hole cruiser/cross-country version...all are drilled for a presta valve. What's the difference? The cross-country version is drilled out to shave some grams; the downhill version is not. What's the weight? At the time of this catalog printing, we don't know yet. We're still testing it to see how much material we can remove before we compromise the structural integrity of the rim. Stay tuned to our website (www.surlybikes.com) for updated tech info and delivery dates.

Obviously, you are going to need a non-standard frame to use this product. There are custom builders, like John Evingson, who can build a frame for you. The disc-compatible Surly 1x1 will work, if you grind off the canti bosses (that does void your frame warranty, however), but you will be limited to a 2.7" tire width. Custom frames can be built to accommodate wider (3"+) tires, if you need maximum traction and floatation.

Constrictor™ Seatpost Clamp



The Constrictor was designed specifically to end slipping seat posts. The extra-thick clamp utilizes an 8mm stainless bolt and accommodates a rear cantilever brake hanger, if you decide to go that route. The Constrictor is machined out of aluminum billet and black anodized. It's available in 30.0mm and 31.8mm sizes.

NEW

Nice Rack™

We thought our Long Haul Trucker touring frame deserved some durable, affordable, expedition-worthy racks to compliment it. So we designed the front and rear Nice Racks.

We chose to make them out of cro-moly (surprised?) due to its durability and ease of repair compared to aluminum. Repairability should be a consideration for any product that will be used in every extreme. In the rare instance that the rack breaks, you should be able to find, even in the most remote regions of planet Earth, somebody to TIG, MIG, stick weld, braze or solder a Nice Rack back together. An aluminum rack won't afford you the same luxury.

Our front rack is a lowrider/highrider design. Panniers mounted in the lowrider position provide a more stable ride, but can be a burden when riding rocky or rutted roads and trails. The upper rails on the rack provide an alternate pannier mounting position for these types of conditions. The rack platform above the wheel increases your cargo capacity. It's a great place to carry a light sleeping bag or small tent if you don't have room elsewhere. Our front Nice Rack mounts directly to forks equipped with a mid-blade eyelet, located 165mm from the dropout eyelet. This is a standard eyelet location found on many touring-specific forks, including our Long Haul Trucker fork. We do, however, provide hardware to securely mount a Nice Rack on forks that do not have a mid-blade eyelet.

Our rear rack is height-adjustable, so you can get your center of gravity as low as possible to provide a stable ride. The hardware included with our rear rack allows it to work with all sizes of our Long Haul Trucker touring frames (42cm - 62cm), so it should easily mount to your frame, as well. The bottom and top rack stays are interchangeable, which limits the amount of spare hardware that you'd need to carry for a long tour. Its wide platform has plenty of room for rack trunks, sleeping bags, tents, bags of cheese, or pieces of old broken dentistry equipment.

Our Nice Racks are satin nickel-plated for corrosion resistance and good looks. The stainless steel hardware we provide will enable you to fit them to most rigid 26" and 700c frames, and to forks equipped with drum, caliper, or cantilever brakes. Disc brakes and suspension are generally not compatible with our racks.

At the time of this catalog printing, samples are still not available for photos. Sorry. We encourage you to check out our website (www.surlybikes.com) for future photos, additional technical information, updates on availability, and possible refinements of our Nice Racks. Of course, we invite you to check out the other great products that Surly has to offer, as well.

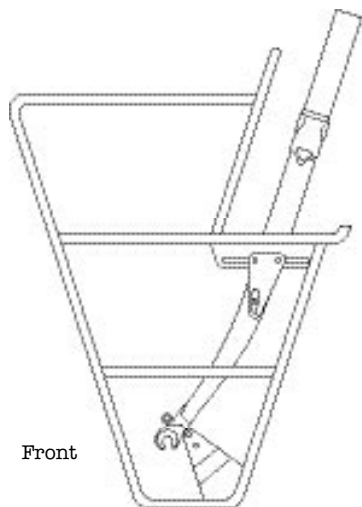

Front

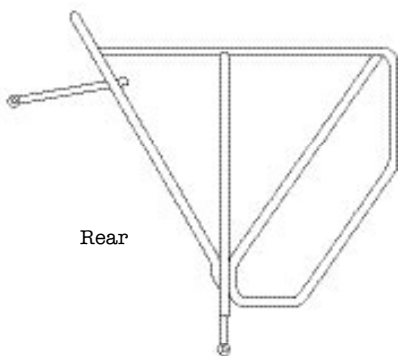

Rear

NEW

25

Stainless Steel Chainrings

Why the heck would we produce chainrings when there are already so many chainrings on the market? Because stainless chainrings are tougher than aluminum chainrings. For single-speed and tandem timing chain applications, where the wear isn't shared between 2 or 3 chainrings, our rings will outlast and outperform aluminum. You can certainly use them for multi-chainring applications, but they aren't ramped or pinned, so shifting up to our ring (used as a middle or outer ring) might be a bit slower than what you are used to. Our rings are compatible with 6-speed to 9-speed chains.

Sizes: 94mm BCD x 30t, 32t, 34t, & 36t.
104mm BCD x 32t, 34t, & 36t.
110mm BCD x 34t & 36t.



Track Cogs

Surly track cogs are machined, not stamped, out of 4041 cro-moly and hardened to resist wear. They are ISO-threaded (1.375 x 24tpi) so they'll fit most English, Italian, and Japanese hubs, including our New fixxie hub and our Fixxer hub converter. Surly cogs are available in 3/32" and 1/8" widths, 13-tooth to 20-tooth sizes, in a silver hue.



Track Lockrings

CNC-machined in USA out of premium stainless steel. No flaking chrome or rusting. Fits English lockring threads (1.29" x 24t LH) and will work on almost all track hubs available today except Campagnolo® (1.32 x 24t LH) or French (33 x 1mm LH)



Disc Housing Guides

Investment cast cro-moly. TIG-weld or fillet braze them on. Plenty o' room for zip ties. They work good.

Frame Dropouts

Our investment cast cro-moly dropouts come in two versions: with or without derailleuse tab. These are the same dropouts that we use on our 1x1, Steamroller, and Karate Monkey frames. They can be TIG-welded or fillet brazed.



NEW

Tuggnut™ Chain Tensioner

Ever stomp on the pedals just to have your rear wheel slide forward in the dropouts and throw your chain? We have....using all kinds of hubs in all kinds of frames. There are a lot of BMX-style tensioners out there, but few of them fit in our dropouts, without some serious grinding. So, we decided to design a chain tensioner that will keep that rear wheel static in our dropouts...and most other kinds of rear-facing horizontal dropouts. Plus, ours will open up a bottle o' brew. The body of the Tuggnut is investment cast in stainless steel for durability. It features a winged bolt for tool-free adjustments, and 2 axle holes for a wide range of fore/aft wheel positions. The Tuggnut comes with an aluminum adapter that reduces the axle hole from 10mm to 6mm, so you can use it with quick-release axles, in addition to nutted axles. We sell it as a single, because you really only need one...on the drive side. But, if you absolutely need one on the non-drive side of your rig, to achieve balance in your life, you are in luck...the bottle opener works either way.



Surly Hip Flask

Stainless steel. 6oz. (177ml)

Holds your precious liquids, and is derby approved. You wouldn't want to fall on a glass bottle would ya?



Jethro Tule™

Not since "Aqualung" was re-released stateside on vinyl has there been a better way to spend twenty bucks. Surly Bikes' new Jethro Tule pocket tool is hand-crafted from stainless-steel, then polished to a high luster, and combines an offset box wrench on one end with a leverage-enhanced bottle opener on the other.

The double-sided 15mm box wrench fits most bolt-off hubs on the market and also quite nicely inside recessed dropouts, including those found on our Surly 1x1 frame. Quit carting around the Vice-grips™; our smooth, spoon-shaped handle provides ergonomic pleasure for your palm under the most rigorous wheel-removing operations at a fraction of the weight and bulk, and snaps open the fizzy reliably before, during, and after the ride. The Jethro Tule hangs nicely on a key chain and is light enough to carry comfortably anywhere, but being "Thick as a Brick", it is built to last and to resist bouncing out of your pocket during a rough singletrack ride, or crosstown jaunt. Ian Anderson traded in that damn flute for one.



27

Surly Profile: Stoooge

Name: Nick Sande

From an early age I had a craving for the taste of beer. At age 4, I wasn't out to get drunk and wash my sorrows down the drain. I simply liked the taste of beer. Cold, fizzy, refreshing, available. I'd often count how many beers my Dad would drink during a football game and wonder why he was so thirsty. As I later discovered, the intoxicating effects of alcohol can make football games more exciting and the consumption levels weren't related to thirst.

So why does beer get a bad rap compared to the evils in this world? My fascination with beer does not necessarily make me an alcoholic. An alcoholic is probably somebody who drinks too much, too often and doesn't know they're negatively affecting their own life and other peoples' lives in the process. In other words, it's not the alcohol that is to blame; it's the person who is consuming it at levels unhelpful to daily life that is to blame. It's not the cell phone that caused the person to crash their car; it was the person who chose to use the phone while driving. It's not the "reality" TV that turns Americans into clueless couch potatoes, it's the viewers who boost ratings and feed the need for more "reality" TV. When somebody spills drive-thru hot coffee on themselves, it's the fault of the person who spilled it on themselves, not the coffee vendor (duh, it's hot, that's what you ordered!). When I crash my bike after too many beers, it's my fault for drinking and riding; not the brewer whose can of beer didn't warn me about the risks of riding singletrack high-speed at night after consuming their product. So it's the responsibility of an individual to take the blame for their actions and make smart decisions that positively affect the environment in which they exist. Right?

My point? Oh yeah, my point is that beer is a good thing. Why else would Belgian monks fast from food and just drink nutrient-rich beer? Or why else would the founding fathers of America brew their own beer? Beer has been around for 8,000 years. So why in the 1920's did the American government prohibit the production and consumption of liquor? Because some people blamed social and financial problems on beer and liquor, not on the actual causes of the downfall of America back then.

There are many similar issues facing America today: lack of jobs, poverty, crappy foreign policy, war, terrorism, racism and pollution. We are given the right to choose what we do and who we vote for in order to make the world a better place. Beer employs people, doesn't piss off other countries, doesn't cause war/hatred/racism/terrorism, is natural and doesn't toxify the environment, tastes good, gives us nourishment and makes me happy. So, can beer save America?

The following statement says a lot: Sometimes when I reflect back on all the beer I drink I feel ashamed. Then I look into the glass and think about the workers in the brewery and all of their hopes and dreams. If I didn't drink this beer, they might be out of work and their dreams would be shattered. Then I say to myself, 'It is better that I drink this beer and let their dreams come true than to be selfish and worry about my liver.' --Jack Handey

Happy trails, hoppy ales.
Nick Sande



Tee Shirts



NEW

Karate Monkey Baseball Tee

- Gray and black
- Sizes: M-XXL



NEW

Karate Monkey Tee

- Black
- Sizes: M-XXL



Long Sleeve Logo Tee

- Black
- Sizes: M-XXL



Girly Tee

- Black
- Sizes: S-XL



Logo Tee

- Black
- Sizes: S-XXL

NEW Wool Jerseys

Men's

- 100% Merino wool
- Available in short or long-sleeve
- 11" zipper
- Rear pockets
- Embroidered logos
- Black
- Sizes: S-XL



**Why Wool?
see page 30**

Women's

- 100% Merino wool
- Available in short or long-sleeve
- 11" zipper
- Rear pockets
- Embroidered logos
- Black
- Sizes: S-XL



Socks

- 75% Merino wool, 25% nylon and spandex
- Black
- Sizes: S/M, L/XL, and XXL Sasquatch
- 2 cuff heights: 3" Racer Geek, and 5" Nerdlinger



Baseball Cap

- Embroidered logo
- Flex-fit
- Black
- Sizes: S/M or L/XL



Why Wool?

Our wool clothes are made from Merino, a very fine, soft, itch-free wool which feels much like cashmere next to the skin. Like all wool, it has wicking characteristics superior to any synthetic. This means it keeps moisture off your skin and insulates to help you maintain a comfortable operating temperature even when the material itself is pretty well soaked (cotton, for example, simply gets wet and makes you feel clammy, so your body uses valuable energy trying to keep you warm). Wool is warm in cool and cold weather (it's the perfect base layer), and yet remains surprisingly comfy when the weather is warm. And because wool fibers can actually absorb moisture, rather than simply pulling it away from your skin, the bacteria that cause synthetics to stink don't build up. In fact, you don't want to wash our wool jerseys and socks every time you wear them. But when it is time to wash them, you can toss them in the machine on the gentle cycle (cold water!) and then air dry them. Back in the day, cyclists all wore wool, and this is better than anything they had back then. Find out why.

Banner

- 36x18"
- Black nylon
- 4 Grommets



Patches

- Sizes:
6.5" wide
10" wide



Stickers

- Sizes:
1.75 x 6.4"
12 x 2.73"
24 x 5.46"



Frame Decal Sets

- Complete decal sets are available for each frame we sell
- Decals are dry transfer style
- Each decal set includes a headbadge



Surly Profile: Ghost in the Machine



I'm supposed to write something about myself, but what should I say? That I like a good story and a good song? That I like a good movie? That I like dogs? That I love to laugh? Or that I believe sadness to be the true source of laughter? What else? That I like the way Spring smells? That I like the way autumn feels? That I find myself fascinated by leaves, how some are thin and veined and skeletal, some plump with water and flesh, how all of them smell good when you break them open and roll them across your fingertips? I like how water pressure holds them up. Plants are hydraulic. I like that the sun and the soil are their sustenance.

All I know is that I have not yet tired of standing my bike in the living room and staring at it. Its lines and curves and simple machines combine to make something much more than the sum of its parts, something inexplicable. Solid but fluid. A kind of poetry that proves itself when put into motion.

I love riding in the country, over long stretches of blacktop, hammering out mile after mile on back roads guarded by pissed off red winged blackbirds, the sun searing me into nothingness. I love flying fast as hell through traffic, floating off curbs and back up the other side, carving corners, motorpacing, darting, weaving, laying it down. I love climbing mountains, rewarded by the burn and unspeakable beauty at the top, then descending...the closest thing I have found to flying.

I am lucky. I get to work doing something I love. I get paid to talk bikes all day. Yeah. I am the ghost in the machine.

Andy Corson

Contact Us

SURLY™
6400 W. 105th St.
Bloomington, MN 55438

Phone: 877.743.3191
Web: www.surlybikes.com
E-mail: derby@surlybikes.com

International Man of Mystery
Sean "Bootsy" Collins
1.800.346.0004 ext. 270

Surly® Engineer
Josh Yablon
1.800.346.0004 ext. 357

SURLY

6400 W. 105th St.
Bloomington, MN 55438