

SURLY®

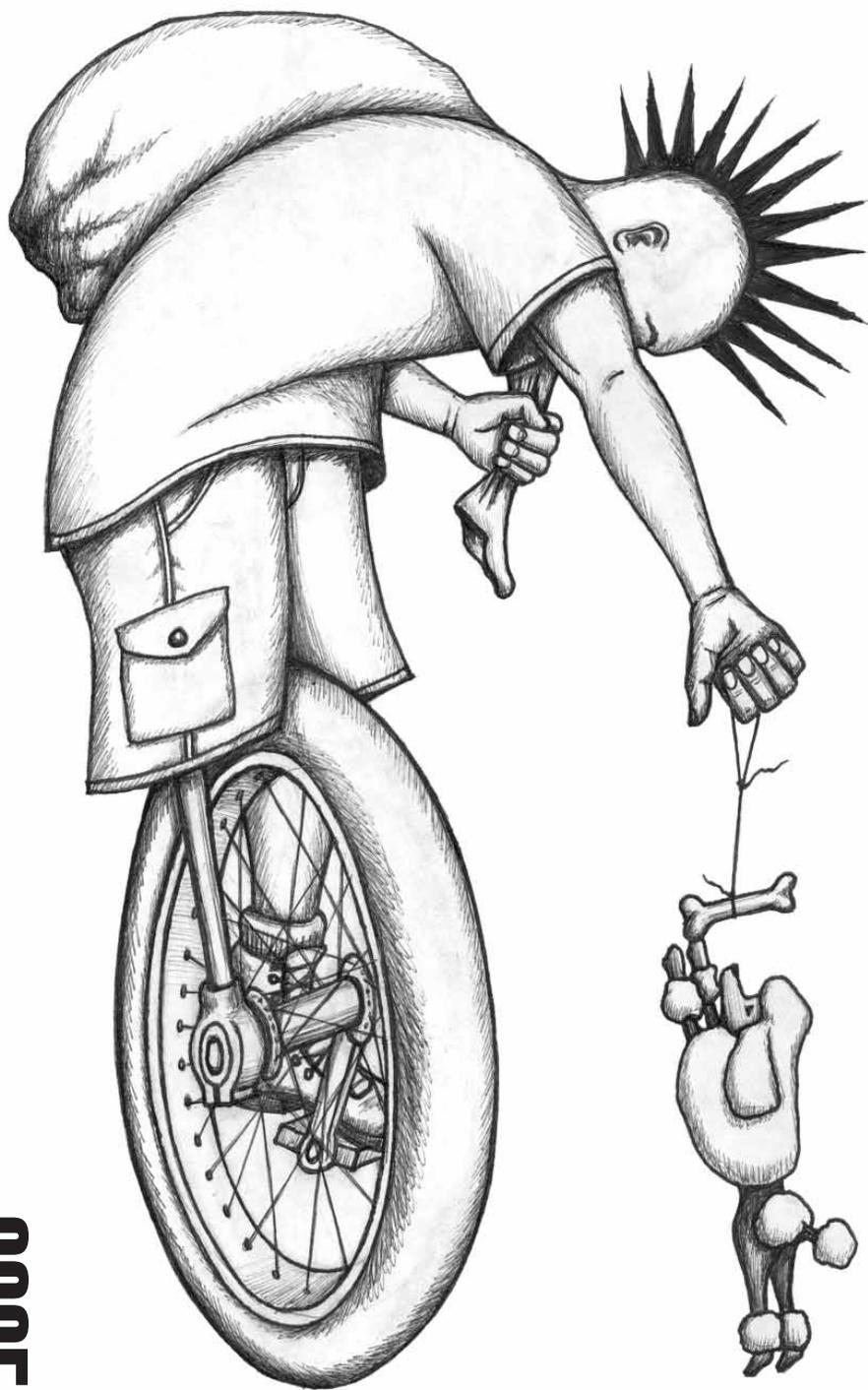

2005

NEW

# Pugsley™ Frameset

Pugsley was created to go where other bikes may flounder. The premise behind its design is based on the allowance of tires with a larger-than-average footprint. Our frame and fork will accept 4" tires (We're working on 'em. Be patient.) on 26" rims. The floatation and traction gained by using large-volume low-pressure tires can get you over and through otherwise-unrideable terrain: ice, snow, sand, mud, wet rocks and roots. In many conditions, bigger is better.

Our 65mm-wide Large Marge rim was the genesis of this project. Without a wide platform for a wide tire, there would be no need for a wide frame. Well, Marge is a reality, so Pugsley must follow. There are lots of 3" tires on the market right now, and they work well in the loose and slick stuff. But, 4" tires will work better much of the time, and they should soon be a reality. We wanted to be prepared for their arrival by designing a frame with loads of space between the stays and between the fork blades. Of course, by providing clearance for 26" x 4" tires, we've also cleared the way for you to use the fattest 29" (700c) rims and tires that you can find. This is a versatile frameset.



**Note: After lacing up some Pugsley offset wheels, we've decided to modify some Large Marge rims to give you more disc-side dish and more even spoke tension. These special Pug rims should be available around the time that Pugsley framesets arrive in our warehouse. Standard Large Marge rims work fine when laced to non-disc hubs in an offset Pug wheel...if you are using your Pug as a fixie or using standard hubs with rim brakes. Non-Surly rims drilled offset, 6-12mm to the drive side, will work fine with disc hubs in the Pugsley frameset.**

There are problems associated with using wide tires: the chain can rub on the tire and the tire can rub on the chainstays. We've addressed the chain/tire issue by offsetting the frame to the drive side (Yes, you'll have to build your wheels offset 17.5mm.), and utilizing a wider bottom bracket shell (100mm) that moves your chainrings out the same distance. The result is a straight chainline and the ability to use a standard drivetrain (compact mountain triple crankset with a full cassette of cogs on a 135mm-spaced hub) without chain/tire interference. Pugsley has horizontal drops with a derailleur hanger. So, you can set it up as a single-speed or internally-g geared rig, if you don't want to use derailleurs. By using the 100mm BB shell, in conjunction with a lot of chainstay manipulation, Pugsley allows you to fit 4" tires between the stays with clearance to spare.

Think about trying to shove a 4" (102mm) tire through the dropouts of a fork designed to accept a 100mm-wide hub. Now, add a disc brake caliper to narrow the gap. What have you got? A big hassle when trying to get a wheel, with an inflated tire, in and out of the fork. We solved the problem by designing the fork to use a wider hub. Pugsley uses a 135mm hub on the rear, so it seemed logical to use one on the front, too. Our rear mountain hubs work great for this application. We offset the fork the same distance as the rear end, so the wheels will be interchangeable. Why would you want interchangeable wheels? 1) If you're using your rig as a single-speed, differently-sized freewheels can be installed on each wheel to give you high and low gear options. 2) You may want a fixed-gear/freewheel option, in case there is a risk of your freewheel seizing up or not engaging when riding in extreme conditions. A fixed cog always moves you forward. And, it can be used to slow you down, if you choose not to use brakes...or if your brakes stop working 3) If you use the same model of hub, front and rear, you'll only use 1 or 2 lengths of spokes vs. 3 or 4...less confusion and fewer spare spokes to carry if you're on a remote tour. If you decide that you don't want to use the Pugsley fork, our Instigator fork (as well as many 100mm-travel suspension forks) have the same axle-to-crown length. So, we give you plenty of fork options to use with our frame.

We provide disc brake tabs on the frame and fork. If you're using discs, you'll have to use rear brakes or rear brake adapters for the frame and the fork. Not everybody needs or wants disc brakes, so we also provide 120mm-spaced removable cantilever pivots for those of you who want to run v-brakes, traditional cantilevers, or Magura hydraulic rim brakes with 26" Large Marge rims.

Who should ride Pugsley? Hunters of all types (animal, mineral, or vegetable), beach/desert riders, snow/ice riders, wilderness explorers, and anybody else in need of a bike that will provide extra stability, traction, and floatation when the terrain gets loose and unpredictable. You should ride Pugsley.

## Pugsley Specifications:

**Tubing:** 100% Surly 4130 cro-moly steel, main triangle double-butt TIG-welded

**Rear dropouts:** Surly horizontal dropouts with derailleur hanger. 135mm-spaced. Offset 17.5mm.

**Brake compatibility:** Most rear international standard disc brakes or cantilever-type rim brakes (when using Large Marge)

**Braze-ons:** Cantilever bosses with removable pivots, dual water bottle mounts, top tube cable housing guides for use with continuous housing, fender and rack eyelets.

**Seatpost diameter:** 27.2mm

**Seatpost clamp diameter:** 30mm. Surly Constrictor™ included

**Headset:** 1-1/8" threadless

**Front Derailleur:** E-type

**Bottom bracket shell:** 100mm wide, 1.37 x 24t

**Chainring clearance:** Compact triple: 22-32-44t

**Fork:** Suspension-corrected...447mm axle to crown, tapered straight blade, 4130 cro-moly. International standard rear disc mount and removable cantilever pivots spaced 120mm apart. 135mm-spaced dropouts, 17.5mm offset.

**Sizes available:** 16", 18", 20" and 22" (measured from the center of the bb to the top of the top tube)

**Color:** Barney Blue/Purple Pearl Sizzurple

**Weight:** Not available Fork - uncut = Not available

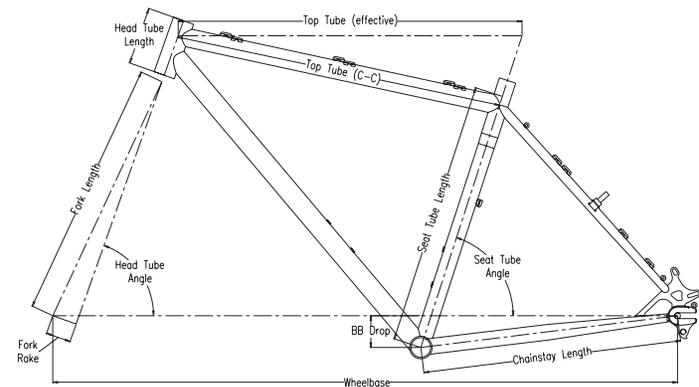

Size	ST (C-T)		TT (C-C)*		TT (Effec.)		HT Angle degrees	ST Angle degrees	BB Drop		CS Length	
	inches	mm	inches	mm	inches	mm			inches	mm	inches	mm
16"	16.0	406.4	21.8	552.5	22.9	580.9	70.5	72.0	2.2	55.0	17.6	448.1
18"	18.0	457.2	22.4	569.5	23.5	595.7	70.5	72.0	2.2	55.0	17.6	448.1
20"	20.0	508.0	23.1	587.3	24.0	610.1	70.5	72.0	2.2	55.0	17.6	448.1
22"	22.0	558.8	24.0	608.6	24.6	625.0	70.5	72.0	2.2	55.0	17.6	448.1

Size	Wheel Base		S.O. Height**		HT Length		FK Length		FK Rake	
	inches	mm	inches	mm	inches	mm	inches	mm	inches	mm
16"	42.0	1067.3	30.8	782.2	3.6	92.0	17.6	447.0	1.7	43.0
18"	42.6	1082.3	32.0	811.6	3.9	100.0	17.6	447.0	1.7	43.0
20"	43.2	1097.3	33.3	845.8	4.7	120.0	17.6	447.0	1.7	43.0
22"	43.8	1112.6	34.5	875.8	5.5	140.0	17.6	447.0	1.7	43.0

\*\* Standover height measured using a very big theoretical 26 x 4.0" tire measuring 740mm in diameter. Subtract 32mm (1.26") for standover height with Tioga 2.1" DH tire measuring 676mm in diameter.

# Long Haul Trucker™ Frameset

In an age of 'epic' this and 'extreme' that, when it appears everything is new and improved, bigger, better, & faster, it might seem antithetic for us to build—or for you to buy—a touring frame. Didn't those die off with the other dinosaurs of the 70's?



Truth is, there is little as epic as a really long bike ride. It resets your mind. It challenges your body and spirit. It stirs and purges, soothes and recharges. "The daily grind" becomes meaningful. Just you, and everything you need to live, packed up on your bike.

So where do you want to go? To work and back everyday? A week long trip to the next state over? Or perhaps La Paz, Bolivia, via Homer, Alaska. Maybe you just want to wake up and wonder where you are. The Surly® Long Haul Trucker is the right tool for the job. It's not flashy, and it's not made of the latest, lightest, thinnest alloy. It is made, like all our frames, of cro-moly steel. Why? Because steel is tough and durable, yet resilient. It soaks up the rough stuff, but remains stiff enough to provide an efficient ride. Sure, aluminum can be tough, and carbon fiber can soak up road static. Heck, titanium even acts a lot like steel. But, there is nothing else that does all the things that steel does for so little money.

We designed the Long Haul Trucker geometry for all day, everyday comfort, even fully loaded (quite different from the vast majority of frames out there). Long chain stays and a laid back head angle provide a comfy platform for day after day after day in the saddle. It's got 3 sets of water bottle cage bosses. It's got braze-ons for carrying a couple of extra spokes. It's got braze-ons for front and rear racks. The head tube is taller on top to help put you in a more upright position and save strain on your neck, back, shoulders, wrists and elbows. The bigger sizes take 700c wheels, while the smaller frames are designed for 26" wheels. So, they fit without toe overlap or compromised handling.

Like all Surlys, it sports practical, standard sizing for things like seatpost, front derailleur, and stem. It even sports downtube shifter braze-ons. All this means you can easily find new parts for it, or use stuff you already have.

The Long Haul Trucker isn't the bike that everyone is going to have. It isn't the next big thing. It won't race like a champ or scream down rocky singletrack. It isn't about impressing your friends. It's a tool for finding out what you are capable of inside. Are you ready to ride?

## Long Haul Trucker Specifications:

**Tubing:** 100% Surly 4130 cro-moly steel, main triangle double-buttet TIG-welded

**Rear dropouts:** Vertical, 135mm

**Brake compatibility:** Linear pull or cantilever

**Braze-ons:** Upper bosses and dropout eyelets for racks front and rear; fender eyelets; chainstay spare spoke holder; pump peg; downtube lever bosses; 3 sets of H<sub>2</sub>O cage bosses; rear housing stop for canti brakes; housing stops for brakes and derailleurs

**Seatpost diameter:** 27.2mm

**Seatpost clamp diameter:** 30mm. Surly Constrictor™ included

**Headset:** 1-1/8" threadless

**Front Derailleur Clamp Diameter:** 28.6mm

**Bottom bracket shell:** 68mm wide, 1.37 x 24t

**Chainring clearance:** 42/53t double, 38/52/56t triple

**Fork:** 4130 cro-moly, lugged and brazed, tapered curved blade w/ lowrider rack eyelet

**Sizes available:** 42cm, 46cm, 50-62cm even sizes

**Color:** Sage Green

**Weight:** 58cm frame = 5.15 lbs. (2.34 kg)

Fork - uncut = 2.25 lbs. (1.02 kg)

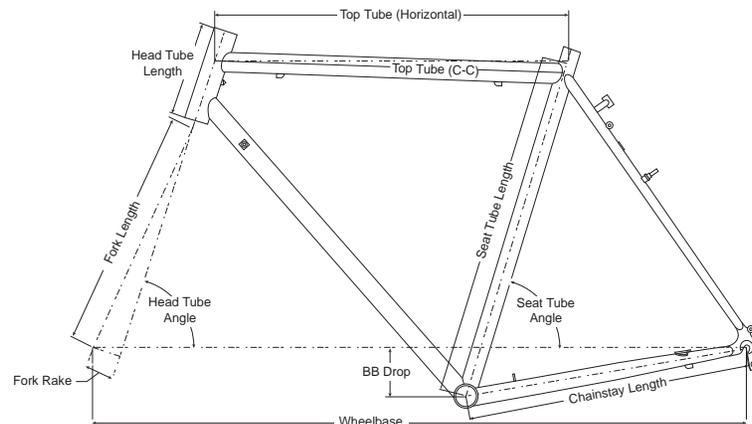

Size	ST (C-T)		TT (C-C)*		TT (Effec.)		HT Angle degrees	ST Angle degrees	BB Drop		CS Length	
	inches	mm	inches	mm	inches	mm			inches	mm	inches	mm
<b>42 cm</b>	16.5	420.0	19.4	492.6	19.9	505.0	70.0	75.0	1.9	47.0	18.1	460.0
<b>46 cm</b>	18.1	460.0	20.0	508.3	20.3	515.0	70.0	74.5	1.9	47.0	18.1	460.0
<b>50 cm</b>	19.7	500.0	20.7	525.0	20.9	530.0	71.0	74.0	1.9	47.0	18.1	460.0
<b>52 cm</b>	20.5	520.0	21.1	534.8	21.3	540.0	71.0	73.5	1.9	47.0	18.1	460.0
<b>54 cm</b>	21.3	540.0	21.6	549.6	21.9	555.0	71.0	73.0	1.9	47.0	18.1	460.0
<b>56 cm</b>	22.0	560.0	22.2	564.4	22.4	570.0	72.0	73.0	3.1	78.0	18.1	460.0
<b>58 cm</b>	22.8	580.0	22.8	580.1	23.1	586.0	72.0	72.5	3.1	78.0	18.1	460.0
<b>60 cm</b>	23.6	600.0	23.4	593.8	23.6	600.0	72.0	72.5	3.1	78.0	18.1	460.0
<b>62 cm</b>	24.4	620.0	23.8	603.5	24.0	610.0	72.0	72.0	3.1	78.0	18.1	460.0

Size	Wheel Size	Wheel Base		S.O. Height**		HT Length		FK Length		FK Rake	
	26" / 700c	inches	mm	inches	mm	inches	mm	inches	mm	inches	mm
<b>42 cm</b>	x	40.8	1036.6	27.7	703.0	4.4	110.7	14.8	376.0	1.8	45.0
<b>46 cm</b>	x	41.1	1042.7	28.5	723.8	4.6	116.7	14.8	376.0	1.8	45.0
<b>50 cm</b>	x	41.2	1046.8	29.8	756.9	5.7	144.0	14.8	376.0	1.8	45.0
<b>52 cm</b>	x	41.5	1053.1	30.5	775.1	6.4	163.0	14.8	376.0	1.8	45.0
<b>54 cm</b>	x	41.9	1064.0	31.2	793.1	7.2	182.0	14.8	376.0	1.8	45.0
<b>56 cm</b>	x	41.6	1055.7	32.0	812.2	6.0	152.0	15.4	390.0	1.8	45.0
<b>58 cm</b>	x	42.0	1066.7	32.7	830.0	6.7	171.0	15.4	390.0	1.8	45.0
<b>60 cm</b>	x	42.6	1080.9	33.5	849.7	7.4	189.0	15.4	390.0	1.8	45.0
<b>62 cm</b>	x	42.7	1085.3	34.1	867.3	8.3	210.0	15.4	390.0	1.8	45.0

\* Center to Center top tube is preliminary and final lengths are subject to change  
 \*\* Standover height for 26" model is a rough estimate based on preliminary drawings using a Primo Racer 26 x 1.25" tire that measures 628mm in diameter. Standover height for 700c model is a rough estimate based on preliminary drawings using a Rivendell (Panaracer) Ruffy Tuffy 700 x 28 (actually closer in size to 700 x 32) tire that measures 690mm in diameter

# Karate Monkey™ 29" Frameset

The Karate Monkey is all about big wheels and versatility. Build it up as a 700c mountain bike, cyclocross bike, commuter, or backcountry tourer. Create your ideal Frankenstein.

We decided to produce a 29er because we thought we could make improvements on the current designs from other manufacturers, while offering a unique, quality frameset at a Surly price. Mission accomplished.

Frameset geometry is the key to the handling characteristics of any bike.

It doesn't matter how pretty it is, or how many braze-ons it has, if it rides like crap.

We want you to use the Karate Monkey on single-track, as well as fire roads and pavement, so we spent time figuring out the best ways to make our rig handle like a mountain bike...not like a tractor. The most obvious frame component of the Karate Monkey is the curved seat tube. This feature allows us to use shorter chainstays without worrying about the rear tire rubbing on the seat tube when the wheel is jammed all the way forward in the dropouts. Shorter chainstays mean quicker handling and better traction at the rear. Toe overlap is another concern with big-wheeled bikes. We tweaked our measurements to eliminate overlap, while maintaining the riding characteristics of a mountain bike.



Options galore. Single-speed? Sure. Like gears? Use some. The Karate Monkey will accommodate a standard or compact mountain triple up front, and a cassette full o'cogs in the 135mm-spaced rear. Our Surly horizontal dropouts are cast with a derailleur hanger, so you have several drivetrain options. Disc brakes or cantilevers? Once again, it's up to you. The Karate Monkey comes with International Standard disc mounts and removable canti pivots. Rigid or suspended front end? We provide a unicrown, tapered straight blade, suspension-corrected rigid fork. Do as you wish.

Like all Surly frames and forks, the Karate Monkey is built with Surly 4130 cro-moly. The butted tubes are thick enough to withstand a derby circle beating, but thin enough to deliver the fine ride characteristics that steel is known for.

Want a trail-worthy, high roller that won't put you in the poor house?

Check out the Karate Monkey.

Size	ST (C-T) mm		TT (C-C) mm		TT (Effec.) mm		HT Angle degrees	ST Angle degrees	BB Drop mm		CS Length mm	
<b>small</b>	16.0	406.4	21.7	552.0	22.7	576.6	71.0	73.0	2.7	68.0	17.0	431.0
<b>medium</b>	18.0	457.2	22.6	574.5	23.6	600.6	71.5	73.0	2.7	68.0	17.0	431.0
<b>large</b>	20.0	508.0	23.4	594.5	24.3	617.5	72.0	73.0	2.7	68.0	17.0	431.0
<b>x-large</b>	22.0	558.8	24.2	614.3	24.9	633.6	72.0	73.0	2.7	68.0	17.0	431.0

## Karate Monkey Specifications:

**Tubing:** 100% Surly 4130 cro-moly steel. Main triangle double-buttet. TIG-welded

**Rear dropouts:** Surly horizontal dropouts with derailleur hanger. 135mm spaced

**Brake compatibility:** Most International Standard disc or cantilever rim-type

**Braze-ons:** Cantilever bosses with removable pivots, dual water bottle mounts, down tube shift cable routing, guides for hydraulic hose or solid housing on the seatstay, standard cable housing stops on the top tube.

**Seatpost diameter:** 27.2mm

**Seatpost clamp diameter:** 30mm. Surly Constrictor included

**Headset:** 1-1/8" threadless

**Front Derailleur Clamp Diameter:** 28.6mm

**Bottom bracket shell:** 73mm wide, 1.37 x 24t

**Chainring clearance:** 48t max

**Fork:** Suspension-corrected, tapered straight blade, 4130 cro-moly. International Standard disc mount and removable canti pivots

**Sizes available:** 16", 18", 20", and 22"  
(measured from the center of the bottom bracket to the top of the top tube)

**Color:** Skidmark Brown Metallic and Pitch Black

**Weight:** 18" frame = 5.73 lbs. (2.6 kg) Fork - uncut = 2.59 lbs. (1.18 kg)

## Geometry:

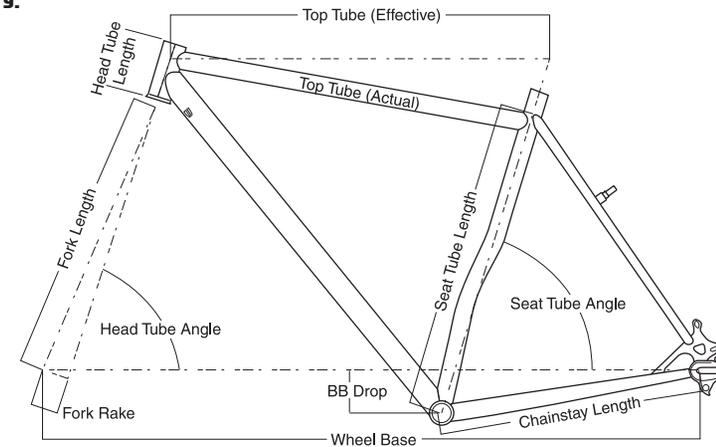

Size	Wheel Base mm	Front-Center mm	S.O. Height** mm	HT Length mm	FK Length mm	FK Rake mm
<b>small</b>	41.1 1044.9	24.5 623.0	30.8 781.6	3.1 80.0	18.4 468.0	1.7 43.0
<b>medium</b>	41.9 1064.0	25.3 642.0	31.9 811.1	3.5 90.0	18.4 468.0	1.7 43.0
<b>large</b>	42.4 1076.1	25.7 654.0	33.0 838.2	3.7 95.0	18.4 468.0	1.7 43.0
<b>x-large</b>	43.0 1092.1	26.4 670.0	34.1 866.8	4.1 105.0	18.4 468.0	1.7 43.0

\*\* Standover height is based on a 29 x 2.1" tire that measured 737mm in diameter

# Pacer™ Frameset

We noticed that the availability of affordable steel road bike framesets had diminished substantially over the last few years. So, we decided to do something about it. Meet the Pacer....Surly's all-day road rig.

What makes a bike an all-day bike? Comfort and reliability. Rides like a bike. It's predictable. The Pacer's conservative geometry and tubing spec lend themselves to a full day in the saddle. Of course, it's equally suitable for those short rides to your favorite watering hole. The 4130 TIG-welded frame and brazed fork are designed to take the edge off the bumps and cracks in the road, but remain laterally stiff for those out-of-the-saddle sprints and climbs.



Though vertical compliance is definitely a goal when designing a new frame, tire clearance is just as important. The casings of your tires flex before your frame and fork do, and wide tires generally flex more than narrow ones, giving you a softer ride. Wide tires can be faster than skinnies on a lot of surfaces that you will encounter on your rig. So, the Pacer was designed to accept 700x28c tires with fenders or 700x32c tires without...while allowing you to use standard-reach or short-reach road caliper brakes.

The Pacer is spec'd with a 1-1/8" threadless fork because of the wide selection of headsets and stems available to accommodate it. Like most Surly frames, this one uses commonly available components: 27.2mm seatpost, 68mm bottom bracket, 130mm rear hub... basically, items that you might have lying around, waiting for a chance to be used. We recommend using standard-reach brakes, but most short-reach fit.

The durability and versatility of the Pacer make it an ideal commuter, day-tripper, and vehicle for exploration. The frame is offered in 9 sizes (42-62cm), so there should be a Pacer that fits you. You won't be disappointed.

Size	ST (C-T)		TT (C-C)		TT (Effec.)		HT Angle degrees	ST Angle degrees	BB Drop		CS Length	
	inches	mm	inches	mm	inches	mm			inches	mm	inches	mm
42 cm	16.5	420.0	19.4	491.5	19.9	506.0	71.5	75.5	2.8	72.0	16.1	410.0
46 cm	18.1	460.0	19.9	504.2	20.3	515.0	71.5	75.0	2.8	72.0	16.1	410.0
50 cm	19.7	500.0	20.7	526.4	20.9	530.0	72.0	74.5	2.8	72.0	16.1	410.0
52 cm	20.5	520.0	21.3	540.0	21.3	540.0	72.5	74.0	2.8	72.0	16.1	410.0
54 cm	21.3	540.0	21.7	550.0	21.7	550.0	72.5	73.5	2.8	72.0	16.3	415.0
56 cm	22.0	560.0	22.2	565.0	22.2	565.0	73.0	73.0	2.8	72.0	16.3	415.0
58 cm	22.8	580.0	22.8	580.0	22.8	580.0	73.5	73.0	2.8	72.0	16.3	415.0
60 cm	23.6	600.0	23.2	590.0	23.2	590.0	73.5	72.5	2.8	72.0	16.3	415.0
62 cm	24.4	620.0	23.8	605.0	23.8	605.0	74.0	72.5	2.8	72.0	16.3	415.0

Frame geometry subject to change

## Pacer Specifications:

**Tubing:** 100% Surly 4130 cro-moly steel. Main triangle double-buttet. TIG-welded

**Rear dropouts:** Vertical Breeze-In dropouts, 130mm spacing

**Braze-ons:** Single fender eyelets front and rear, dual water bottle mounts, and pump peg (54cm and larger)

**Seatpost diameter:** 27.2mm

**Seatpost clamp diameter:** 30.0mm Surly Constrictor included

**Headset:** 1-1/8" threadless.

**Front Derailleur Clamp Diameter:** 28.6mm

**Bottom bracket shell:** 68mm wide, threaded English 1.37x24t

**Tire clearance:** Room for 700x32c or 700x28c with fenders

**Color:** Midnight Black

**Weight:** 56cm = 4.45 lbs. (2.02 kg) Fork - uncut = 2.09 lbs. (.95 kg)

## Geometry:

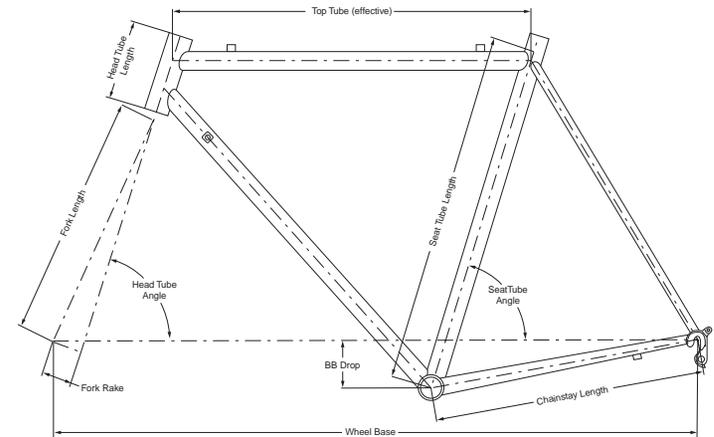

Size	Wheel Base		S.O. Height**		HT Length		FK Length		FK Rake	
	inches	mm	inches	mm	inches	mm	inches	mm	inches	mm
42 cm	38.4	974.4	28.2	715.3	3.5	89.0	14.6	371.0	2.0	50.0
46 cm	38.5	978.8	28.9	735.2	4.1	104.0	14.6	371.0	2.0	50.0
50 cm	38.8	985.6	29.8	756.1	4.1	104.0	14.6	371.0	2.0	50.0
52 cm	38.9	987.2	30.2	767.9	4.3	109.0	14.6	371.0	2.0	50.0
54 cm	39.1	992.8	30.9	785.7	4.9	124.0	14.6	371.0	1.8	45.0
56 cm	39.3	998.7	31.6	803.5	5.6	141.0	14.6	371.0	1.8	45.0
58 cm	39.7	1008.6	32.4	822.7	6.3	159.0	14.6	371.0	1.8	45.0
60 cm	39.9	1013.7	33.1	840.2	6.9	176.0	14.6	371.0	1.8	45.0
62 cm	40.3	1023.4	33.8	859.3	7.6	194.0	14.6	371.0	1.8	45.0

\*\* Standover height is based on a 700 x 25c Michelin Axial Pro tire that measured 680mm in diameter

# Instigator™ Frame

The **Instigator**. While we really don't want to tell you what you can or can't do with the multi-purpose Instigator, consider "urban assault vehicle", "jumper", "freerider", "dual-slammer", or "wall art." We haven't just slapped a bunch of gussets on a mountain bike to achieve the desired aesthetic. We have tried to correct some of the glaring mistakes found in other bikes of this genre, incorporating some standard and unique Surly features at the same time. We're sure the result of our efforts will have you riding "over your head" in no time.

## What's so special about the Instigator?

### 100% Surly 4130 double-butted cro-moly steel construction

Nowadays, it costs more to make a production bike out of cro-moly steel than it does out of name-brand aluminum. We do it not because we dislike aluminum, but because we strongly believe in steel's superior physical and spiritual properties, not to mention the advantages its use lends to this particular design. Technical spew aside, you'll find the Instigator extremely stiff yet comfortable, and of the same extreme strength you'll find in BMX jumping bikes, 99% of which are still made out of steel. And yes, that's a 1.5" diameter double-butted down tube!



### Thick Investment Cast 4130 disc-compatible dropouts

Instigator dropouts are very thick, very strong and very flex-free, as any dropout securing a wheel and brake caliper down 11 flights of stairs should be. Should you choose the disc brake option, the cantilever studs can be removed to save 22 grams and give that sexy, finished look.

### ICGS (International Chain Guide Standard) mounts

Chainguide toughguys Mr.Dirt™ and MRP™ got their heads together to develop a chainguide mounting standard that is simple, straightforward, and keeps everything in place without weird little set screws or drilling holes in down tubes. It's there if you need it, doesn't interfere with front derailleur positioning (if you go that route) and it works great.

### Junk Saver™ top tube

If you simply adjust conventional rigid mountain bike geometry to ride well with 100-130mm suspension forks, the front end of the bike is raised so high that when you get a size that fits you, you have little or no standover clearance. We like as much clearance as possible on a bike like this, but not at the expense of proper fit. With the Instigator's Junk Saver top tube design, you get the best of all worlds – the travel, the right fit, and the clearance you need to clean tricky maneuvers and keep those "important packages" safe.

### FFF™ chainstays

It's awfully silly that a rigid bike with big-travel up front wouldn't provide clearance for a big shock-absorbing tire out back. Not everyone wants to run giant tires. But, the option should always be yours, especially on a bike like the Instigator. Custom-designed Fatties Fit Fine chainstays are standard equipment on all Surly bikes, and, in this case will fit the enormous 26x2.35" Tioga® Factory DH™ with no problem, or even the Intense® 26x2.7" on a 30mm rim. If you run disk brakes, 24x3.0" tires fit, providing the ultimate moto experience.

### Gusseted and reinforced front end

Ahh, the ubiquitous gusseted front end. Ya gotta have it, and it looks cool. Ours features an extra-thick headtube with machined-in reinforcing ring, a downtube gusset, and two beefy side plates to get the job done right. A 5" travel suspension fork is a pretty long lever.

It goes without saying that the Instigator frame isn't light – 6.4lbs. for the 16" and 6.6lbs for the 18" size – but not bad for a bike like this. Expect complete bikes to weigh 27-40 lbs, depending on your component selection and particular need of beefiness.

## Instigator Specifications:

**Tubing:** 100% Surly 4130 cro-moly steel. Main triangle double-butted. TIG-welded

**Rear dropouts:** Proprietary Surly 4130. Spaced 135mm

**Brake compatibility:** International Standard disc or Cantilever rim-type

**Braze-ons:** Removable cantilever bosses, dual water-bottle mounts, Down tube shift cable routing, guides for hydraulic hose or solid housing, ICGS Chainguide mount

**Seatpost diameter:** 29.4mm

**Seatpost clamp diameter:** 31.8mm (1-1/4") Surly Constrictor included

**Headset:** 1-1/8" threadless

**Front derailleur size:** 31.8mm (1-1/4") bottom pull

**Bottom bracket shell:** 73mm wide, threaded English 1.37x24t

**Chainring clearance:** 48t max

**Fork compatibility:** Geometry is designed around a 100mm-130mm suspension fork. Using shorter or longer forks will compromise intended ride characteristics, i.e. less BB clearance, faster or slower handling, etc.

**Color:** Jet Black

**Weight:** 18" = 6.61 lbs. (3.0 kg)

## Geometry:

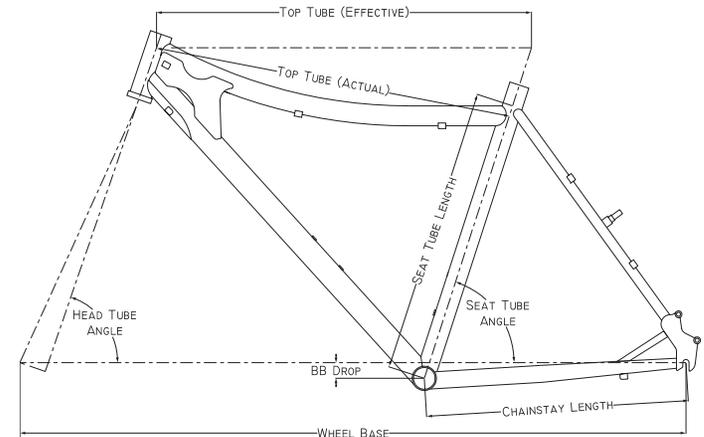

Size	ST (C-T)		TT (C-C)		TT (Effic.)		HT Angle degrees	ST Angle degrees	BB Drop		CS Length	
	inches	mm	inches	mm	inches	mm			inches	mm	inches	mm
<b>x-small</b>	14.0	355.6	21.0	533.5	22.0	558.8	71.0	72.0	0.9	24.0	16.7	425.0
<b>small</b>	16.0	406.4	21.5	546.6	22.6	573.9	71.0	72.0	1.0	25.0	16.7	425.0
<b>medium</b>	18.0	457.2	22.6	574.4	23.6	599.3	71.0	72.0	1.0	25.0	16.7	425.0
<b>large</b>	20.0	508.0	23.8	604.1	24.6	624.4	71.0	72.0	1.0	25.0	16.7	425.0

	Wheel Base**		S.O. Height*		HT Length		FK Length		FK Rake	
	inches	mm	inches	mm	inches	mm	inches	mm	inches	mm
<b>x-small</b>	41.1	1044.3	28.0	711.9	4.3	110.0	N/A	N/A	N/A	N/A
<b>small</b>	41.2	1045.3	29.0	737.1	4.3	110.0	N/A	N/A	N/A	N/A
<b>medium</b>	41.9	1064.7	30.4	773.0	4.3	110.0	N/A	N/A	N/A	N/A
<b>large</b>	43.1	1096.0	32.0	813.7	5.1	130.0	N/A	N/A	N/A	N/A

\* Measurement taken using tire diameter of 676 mm (Tioga 2.1 DH), will vary with tire choice

\*\* Measurement taken using Marzocchi Z1 w/ 100mm travel, will vary with fork choice

N/A = Frame sold sans fork.

Our  
Complete Bike!

# Cross-Check™



A cyclocross bike by category, the Cross-Check has proven itself over and over in the real world, on the streets, in the dirt, through muck and sleet, blazing sun and dark of night, over exhilarating trails, through hectic traffic and long stretches of uninterrupted back road boredom. Are we serious? Absolutely. People have written us time and again telling us how they use it as their commuter, their around-towner, their touring bike; and each time, invariably, they compliment its handling, comfort, and durability (so happy, they seem to forget how affordable it was).

Out of the box, it's a study in value. We carefully selected components that were light enough to make riding it enjoyable, but not stupid-light. Sometimes, with other bikes, durability overshadows comfort and ease of use. Not the Cross-Check. Wide bar, bar-end shifters, a comfy saddle, enough gears to handle any terrain, and, of course, the 4130 cro-moly frame and fork that simply beg to be ridden. And ride you will. You'll be knocked out by its handling, the way it carves a corner and sucks up road static. It's responsive when you turn the bar or stomp on the pedals, but it's predictable, not whippy.

The way we set it up, you may never change a thing about it. But if you're like us, you'll start to tinker, and this is the bike for that. We began with common sizing for things like seatpost, front derailleur clamp, stem, and headset. We gave it eyelets so you can add a rack or fenders. Then we added some smooov Surly touches. Our Gnot-rite™ rear spacing accepts road or mountain hubs. The brake pivots come sporting traditional cantilevers, but it takes linear pull brakes just as easily. The rear dropouts are semi-horizontal with long slots, so you can rock it out as a single speed. Big rings? Fat tires? Add our Fixxer™ and run it as a fixed gear? Yes, yes, oh lord, yes. What won't it do? Drain your wallet of every last penny, that's what.

Think of the Cross-Check like an army jeep: tough as nails and used for everything. Perhaps, because of its utilitarian qualities, it has a special kind of kung fu... a balance of value and versatility we think you'll appreciate. It isn't the result of market research, nor did we just stumble onto something. We ride bikes. We love bikes. This is a work of devotion.

It is deliberate. A machine which animates personal freedom. And we think that's beautiful.

**Tubing:** 100% Surly 4130 cro-moly steel. Main triangle double-butted. TIG-welded.

**Rear dropouts:** Long horizontal dropouts with adjusters feature single-speed compatibility and wheelbase adjustability. Our exclusive Gnot-rite 132.5mm spacing accommodates 130mm road or 135mm MTB hubs, should you want to switch wheels between bikes and whatnot.

**Chainring clearance:** Though we haven't tried a '56', we manipulated the chainstays heavily so you can fit whatever size rings you want. So, go for it!

**Downtube cable routing:** Simply put, top-tube routed shifter cables aren't any better, and they look crummy. Our downtube routed cables look clean, and don't promote water dribblin' down the rear derailleur cable.

**Colors:** Dark Green Metallic or Gloss Black

We could go on and on, but we'll get to the point: The Cross-Check is a sweet bike that is affordable, fun to ride, and built to last a long time. Once a competent, independent bicycle dealer assembles and preps your bike, you'll be trail bound and unable to wipe the grin off your face. Let us know how it goes...

## Cross-Check Geometry:

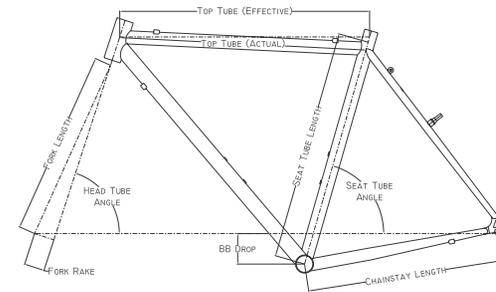

See next page for a complete Cross-Check frame geometry grid.  
Weight: 54cm = 24.6 lbs (11.16kg)

## Component Sizing:

Size	Stem Length inches	Stem Length mm	Stem Angle** degrees	Hbar Width inches	Hbar Width mm	Crank Length inches	Crank Length mm
42 cm	2.0	50.0	84.0	15.7	400.0	6.7	170.0
46 cm	3.1	80.0	84.0	15.7	400.0	6.7	170.0
50 cm	3.1	80.0	84.0	16.5	420.0	6.7	170.0
52 cm	4.1	105.0	96.0	16.5	420.0	6.7	170.0
54 cm	4.1	105.0	96.0	17.3	440.0	6.9	175.0
56 cm	4.1	105.0	96.0	17.3	440.0	6.9	175.0
58 cm	4.7	120.0	96.0	17.3	440.0	6.9	175.0
60 cm	4.7	120.0	96.0	18.1	460.0	6.9	175.0

\*\* Stems can be flip-flopped to customize angle.

## Bike Specifications:

Component	Type	Description
Frame	Surly Cross-Check	100% Surly 4130 cro-moly steel. Main triangle double-butted. TIG welded. Rear rack bosses. Dark Green Metallic or Gloss Black.
Fork	Surly Cross-Check	100% cro-moly, lugged + brazed crown. 1-1/8" threadless steerer.
Headset	Ritchey Logic Comp	1-1/8" threadless, w/ 15mm spacers. Black.
Stem	Tahoma	1-1/8" threadless. Forged. Black.
Handlebars	Salsa Moto Ace Bell-Lap	26.0mm clamp diameter. Black.
Handlebar Wrap	Co-Union Cork Mix	Feels good. Black.
Brake Levers	Shimano	#BL-R400 aero.
Brakes	Tektro Cantilevers	#862A. Silver.
Cable Hanger, front	Tektro	#1271A. Includes routing noodle. Black.
Cable Hanger, rear	Dia-Compe	#1266. Silver.
Shift Levers	Shimano Bar-end type	#SL-BS77. 9-speed.
Front Derailleur	Shimano Tiagra	#FD-4400 Double.
Rear Derailleur	Shimano Tiagra	#RD-4400-GS Mid-cage.
Crankarms	Cyclone	110mm BCD. Silver.
Chainrings	Salsa	36 x 48t.
Pedals	NOT INCLUDED	NOT INCLUDED
Bottom Bracket	Shimano Deore LX	#BB-UN53 68x113mm.
Seatpost	Kalloy Uno	27.2x250mm. Black.
Seatpost Clamp	Surly Constrictor	Black.
Saddle	Velo Endzone	Steel rails, vinyl cover. Black.
Cassette	Shimano Tiagra	#HG-50 9-speed 12-13-14-15-17-19-21-23-25T.
Chain	Shimano HG-72	9-speed compatible.
Hubs	Shimano Deore	#HU-M510. 32 hole. 100mm O.L.D. front, 135mm O.L.D. rear. Black.
Spokes	Stainless Steel	DT Swiss Straight-gauge 14 w/ brass nipples.
Rims	Alex	#AL-DV15. 32 hole x 700c. Silver.
Tires	Ritchey SpeedMax Cross	700x32c. Wire bead. Black wall.
Tubes	Cheng Shin	Standard presta valve 700x32c.

Extras: Clear chainstay protector. Die-extruded cables with anti-rattle donuts. Full CPSC reflector kit. Generic owner's manual

# Cross-Check™ Frameset

The Cross-Check has been good to us. No secret why. It's because it's been good to you. Why do people like it so much? Well, for starters, it's steel. Steel rides like nothing else (when was the last time you saw a spring made of aluminum?), takes a lot of crap, and doesn't cost an arm and a leg. Then we threw down some crazy-good ideas, like semi-horizontal dropouts with a derailleur hanger, our FFF stays so you can run big, fat tires (even with fenders), long-popular measurements for things like front derailleur clamp and seatpost, and our Gnot-Rite rear spacing that takes mountain and road hubs.



What does all this mean to you? Options, kid, that's what. Get yer freak on. Gears? Great. Single speed? No sweat. Commuter? Touring bike? Grocery getter? Bring it on. Or, build it as a bonafide 'cross bike and race it. It likes it.

Best of all, it's actually affordable. You'll need to ask your local shop what they'll charge you, but suffice to say that it is among the most affordable of well-designed, well-built frames around. Whether it's the latest addition to your herd or the only bike you own, the Crosscheck will amaze you with its comfort, versatility and affordability.

Size	ST (C-T)		TT (C-G)		TT (Effec.)		HT Angle degrees	ST Angle degrees	BB Drop		CS Length	
	inches	mm	inches	mm	inches	mm			inches	mm	inches	mm
<b>42 cm</b>	16.5	420.0	19.9	505.0	20.6	522.0	72.0	75.0	2.6	66.0	16.5	420.0
<b>46 cm</b>	18.1	460.0	20.3	515.0	20.8	528.8	72.0	74.5	2.6	66.0	16.5	420.0
<b>50 cm</b>	19.7	500.0	21.1	535.0	21.3	541.8	72.0	74.0	2.6	66.0	16.7	425.0
<b>52 cm</b>	20.5	520.0	21.5	545.0	21.5	547.1	72.0	73.5	2.6	66.0	16.7	425.0
<b>54 cm</b>	21.3	540.0	22.0	560.0	22.0	560.0	72.0	73.0	2.6	66.0	16.7	425.0
<b>56 cm</b>	22.0	560.0	22.4	570.0	22.4	570.0	72.0	72.5	2.6	66.0	16.7	425.0
<b>58 cm</b>	22.8	580.0	22.8	580.0	22.8	580.0	72.0	72.5	2.6	66.0	16.7	425.0
<b>60 cm</b>	23.6	600.0	23.6	600.0	23.6	600.0	72.0	72.0	2.6	66.0	16.7	425.0
<b>62 cm</b>	24.4	620.0	24.0	610.0	24.0	610.0	72.0	72.0	2.6	66.0	16.7	425.0

## Cross-Check Specifications:

**Tubing:** 100% Surly proprietary 4130 cro-moly tubing. TIG-welded. Double-buttet main triangle

**Rear dropouts:** Semi-horizontal dropouts with adjusters give you single speed compatibility and wheel base adjustability. Our Gnot-rite spacing (132.5mm) allows you to run 130mm road hubs and 135mm MTB hubs

**Braze-ons:** Bosses front and rear to take cantilever or linear pull brakes, eyelets at the dropouts, rear rack bosses and dual water bottle mounts. Frames produced in 2005 will sport downtube shifter bosses

**Seatpost diameter:** 27.2mm

**Seatpost clamp diameter:** 30.0mm (we include our Constrictor clamp with our framesets)

**Headset/stem:** 1-1/8" threadless

**Bottom bracket:** 68mm wide, standard English threaded 1.37x24t

**Tire clearance:** Fatties Fit Fine (FFF) stays and our beautiful slope-crowned custom fork provide room for tires up to 700x45 with mud and fender clearance. For real!

**Chainring clearance:** Manipulated so you can fit the size rings you want. Go nuts.

**Color:** Dark Green Metallic or Gloss Black

**Weight:** 56cm = 4.88 lbs. (2.2 kg) Fork - uncut = 2.19 lbs. (.99 kg)

## Geometry:

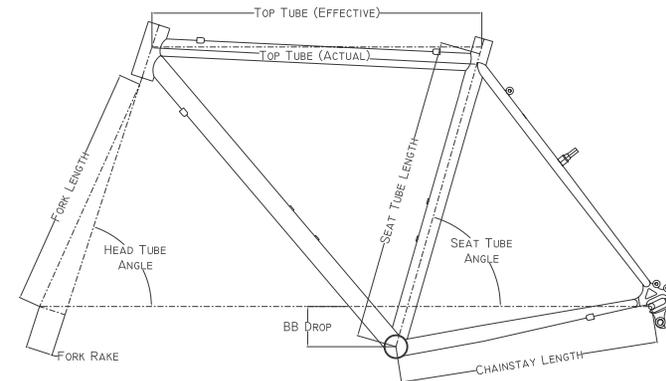

Size	Wheel Base		S.O. Height*		HT Length		FK Length		FK Rake	
	inches	mm	inches	mm	inches	mm	inches	mm	inches	mm
<b>42 cm</b>	39.0	989.9	28.8	731.9	3.6	91.0	15.7	400.0	1.7	44.0
<b>46 cm</b>	39.1	991.9	29.6	750.7	3.6	91.0	15.7	400.0	1.7	44.0
<b>50 cm</b>	39.6	1005.3	30.3	769.4	3.6	91.0	15.7	400.0	1.7	44.0
<b>52 cm</b>	39.6	1006.0	30.6	778.4	3.6	91.0	15.7	400.0	1.7	44.0
<b>54 cm</b>	39.9	1014.4	31.2	793.0	4.0	102.0	15.7	400.0	1.7	44.0
<b>56 cm</b>	40.1	1019.8	31.9	810.7	4.8	121.0	15.7	400.0	1.7	44.0
<b>58 cm</b>	40.6	1030.0	32.7	829.9	5.6	141.0	15.7	400.0	1.7	44.0
<b>60 cm</b>	41.1	1044.8	33.4	847.4	6.3	160.0	15.7	400.0	1.7	44.0
<b>62 cm</b>	41.5	1054.7	34.1	866.2	7.1	180.0	15.7	400.0	1.7	44.0

\*Measurements use tire with 685 mm outer diameter (Ritchey™ 700c x 30 SpeedMax™), and taken from middle of top-tube to level ground.



# Steamroller™ Frameset

A steamroller has the ability to flatten anything in its path, which is exactly how you'll feel the first time you take our Surly Steamroller fixed-gear for a twirl. Unstoppable. Euphoric. Happy. If you haven't ridden 'fixed' before, you might even feel a little bit scared.



It was designed specifically to give you the ideal foundation for a pure and unadulterated fixed-gear bicycle. Some will see the Steamroller and think "messenger", while others will automatically think "track". We hope you'll think about those two, plus "coffee shop", "watering hole", "commuter", "urban assault", "double century" and whatever else. What you do with it is up to you. We can only hope you won't let your preconceived notions about fixed-gear bikes impair your ability to realize the possibilities of the Steamroller frame. The only thing it wasn't designed to do is coast. Although, if you decide to strap a coaster brake out back, we won't spoil your plans. Do what you like, because as with all Surly products, this frameset is merely another platform to expand your horizons and bring your rides to a new or different level of enjoyment.

Since reliable freewheeling technology evolved decades ago, folks have ridden fixed gears by choice, not out of necessity. We won't try to convince you that riding 'fixed' is better or special or why you should try it; you'll have to determine that for yourself. Gee, the Steamroller just might change your life (if this happens please call us)!

The Steamroller geometry, tubing choices and features (or lack thereof) are deliberate in our quest to bring you a balance of pure aesthetics and a ride that is aggressive enough to be quick, exciting and purposeful, yet just mellow enough to be ridden all day long in comfort. We gotta point out the nice fork crown. It's even drilled for a long-reach safety brake, should you opt for one. The seatstay bridge is drilled for a standard-reach brake, as well... though there are no housing stops.

The Steamroller is available in 5 sizes to fit a spectrum of riders, and was designed by fixed-gear riders for fixed-gear riders.

## Steamroller Specifications:

**Tubing:** 100% cro-moly steel. Main triangle is double-buttet. TIG-welded

**Rear dropouts:** Investment cast Surly track dropouts, spaced 120mm apart

**Braze-ons:** None, baby. Pure. OK, we put one set of water-bottle mounts on the seat tube 'cause we're not camels

**Seatpost diameter:** 27.2mm

**Seatpost clamp diameter:** 30.0mm Surly Constrictor, included

**Headset:** 1-1/8" threadless

**Bottom bracket shell:** 68mm wide, threaded English 1.37x24t

**Tire clearance:** Proprietary FFF (Fatties Fit Fine) chainstays and our custom fork give room for tires up to 700x38c with fender clearance left over (P.S. - use clip-on fenders!!)

**Chainring clearance:** Heavy manipulation of the FFF stay gives room for a 50t ring while maintaining chainline. Track crank compatible.

**Color:** Charcoal Metallic

**Weight:** 56cm = 4.5 lbs. (2.0 kg)

Fork - uncut = 1.87 lbs. (.85 kg)

## Geometry:

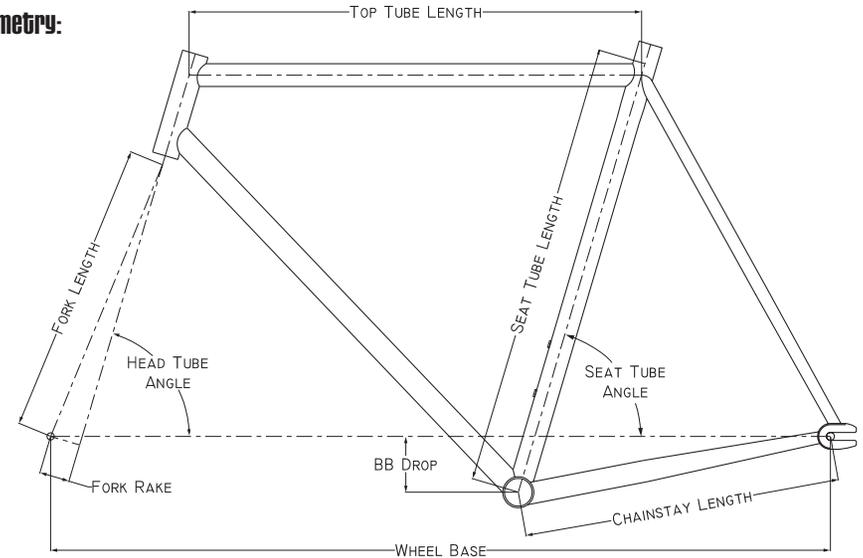

Size	ST (C-T)		TT (C-C)		TT (Effec.)		HT Angle		BB Drop		CS Length	
	inches	mm	inches	mm	inches	mm	degrees	degrees	inches	mm	inches	mm
<b>49 cm</b>	19.3	490.0	20.7	526.5	20.8	529.5	72.5	74.5	2.8	70.0	15.7	398.0
<b>53 cm</b>	20.9	530.0	21.5	547.0	21.5	547.0	73.0	74.0	2.8	70.0	15.7	398.0
<b>56 cm</b>	22.0	560.0	22.4	568.0	22.4	568.0	73.5	73.5	2.8	70.0	15.7	398.0
<b>59 cm</b>	23.2	590.0	23.1	587.0	23.1	587.0	74.0	73.0	2.8	70.0	15.7	398.0
<b>62 cm</b>	24.4	620.0	23.9	608.0	23.9	608.0	74.0	73.0	2.8	70.0	15.7	398.0

Size	Wheel Base		S.O. Height*		HT Length		FK Length		FK Rake	
	inches	mm	inches	mm	inches	mm	inches	mm	inches	mm
<b>49 cm</b>	38.0	965.7	29.5	748.5	3.3	83.0	14.8	375.0	1.5	38.0
<b>53 cm</b>	38.1	966.6	30.7	780.5	4.3	109.0	14.8	375.0	1.5	38.0
<b>56 cm</b>	38.5	978.6	31.8	807.9	5.4	136.0	14.8	375.0	1.5	38.0
<b>59 cm</b>	38.9	987.6	32.9	835.2	6.4	163.0	14.8	375.0	1.5	38.0
<b>62 cm</b>	39.7	1009.1	34.1	865.3	7.7	196.0	14.8	375.0	1.5	38.0

\* Measurements use tire with outer diameter of 682 (700c x 28), and taken from middle of top-tube to level ground.

# 1x1™ Frameset

Nobody wants to spend a bunch of cash on a single-speed...and why should they? To do so is contrary to the whole spirit of the single-speed experience. At Surly we have known this for years and are continuing to offer our excellent 1x1 single-speed frameset. The 1x1 features a beefy, double-butted 100% cro-moly suspension-corrected frame and 1-1/8" hard fork with very nice black or white powder coating and cool white decals.



The motivations to purchase a 1x1 are endless. Maybe you need a derby-rated steed. Maybe your financial sensibilities have kicked into overdrive at the sight of thick 4130 steel for a price you can justify. Perhaps the wide, curvy stays tempt you to try stuffing in some flat-trackin' skins. Maybe you can't stomach the extra twelve cents per gallon for premium, or maybe you just wanna try something new. Whatever the reason, we're sure you will appreciate the form, function, and value of the 1x1 as much as we do.

How does it ride? Take a look at our detailed geometry chart and you'll see our design is, well, regular. Take the 1x1 for a spin and you'll find that it merely "rides like a bike" - leaving you right at home to forget about the machine and enjoy the ride.

The 1x1 is available in x-small, small, medium, large, and x-large sizes. Designed by single-speeders for single-speeders. As with all things Surly, you can't go wrong. Keep lookin' our way for more good deals on tough cro-moly bikes, framesets, and unique components.

## 1x1 Specifications:

**Tubing:** 100% cro-moly steel. Main triangle is double-butted. TIG-welded

**Rear dropouts:** Investment cast Surly track dropouts, spaced 135mm apart

**Braze-ons:** I.S. disc tabs and removable cantilever bosses front and rear, fender eyelets front and rear, and dual water-bottle mounts

**Seatpost diameter:** 27.2mm

**Seatpost clamp diameter:** 30.0mm Surly Constrictor, included

**Headset:** 1-1/8" threadless

**Bottom bracket shell:** 73mm wide, threaded English 1.37x24t

**Tire clearance:** Proprietary FFF (Fatties Fit Fine) chainstays and our custom fork give room for tires up to 2.7" with plenty of mud and fender clearance left over. Seriously!

**Fork:** Suspension corrected for 3" travel sus fork. 100% cro-moly

**Colors:** White or Cash Black

**Weight:** 18" = 5.0 lbs. (2.3 kg) Fork - uncut = 2.34 lbs. (1.1 kg)

## Geometry:

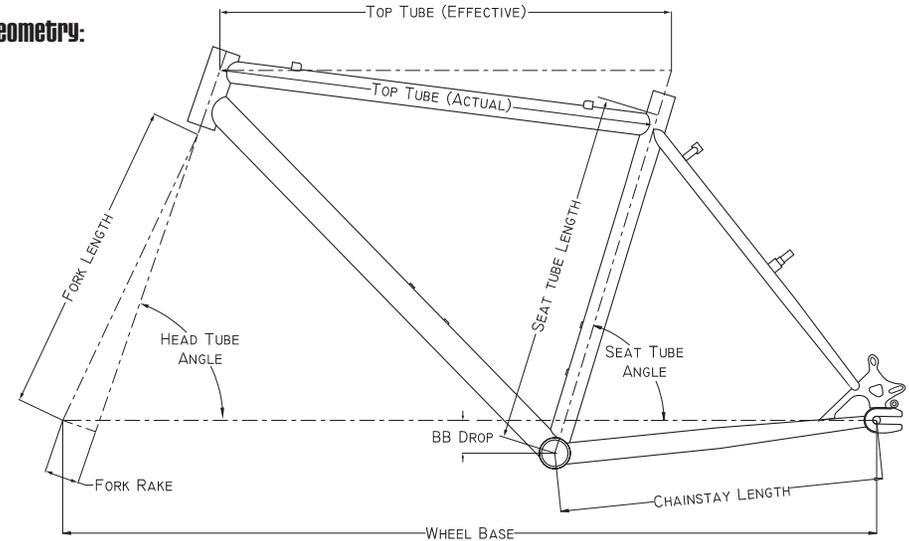

Size	ST (C-T)		TT (C-C)		TT (Effec.)		HT Angle degrees	ST Angle degrees	BB Drop		CS Length	
	inches	mm	inches	mm	inches	mm			inches	mm	inches	mm
<b>x-small</b>	14.0	355.6	20.5	521.2	21.5	545.0	71.0	73.0	1.7	42.5	16.5	419.0
<b>small</b>	16.0	406.4	21.3	541.6	22.2	565.0	71.0	73.0	1.7	42.5	16.5	419.0
<b>medium</b>	18.0	457.2	22.3	565.8	23.0	585.0	71.0	73.0	1.7	42.5	16.5	419.0
<b>large</b>	20.0	508.0	23.1	586.5	23.6	600.0	71.0	73.0	1.7	42.5	16.5	419.0
<b>x-large</b>	22.0	568.8	23.9	608.3	24.2	615.0	71.0	73.0	1.7	42.5	16.5	419.0

Size	Wheel Base		S.O. Height*		HT Length		FK Length		FK Rake	
	inches	mm	inches	mm	inches	mm	inches	mm	inches	mm
<b>x-small</b>	39.9	1013.5	28.1	714.9	3.5	89.0	16.3	413.0	1.8	45.0
<b>small</b>	40.7	1034.0	29.2	742.9	4.0	102.0	16.3	413.0	1.8	45.0
<b>medium</b>	41.5	1054.3	30.5	773.8	4.5	114.0	16.3	413.0	1.8	45.0
<b>large</b>	42.1	1070.1	31.8	806.9	5.3	134.0	16.3	413.0	1.8	45.0
<b>x-large</b>	42.7	1085.8	33.1	841.6	6.3	159.0	16.3	413.0	1.8	45.0

\* Measurements use tire with diameter of 676 mm (Tioga™ 2.1 DH), and taken from middle of top-tube to level ground.

# Forks



## Karate Monkey

The Karate Monkey rigid fork replaces suspension forks designed for use on 29"-wheeled bikes. It features International Standard disc mounts, removable canti pivots, 1-1/8" threadless steerer, tapered straight blades, and a black powdercoat finish. 468mm axle to crown.

**Rake:** 43mm

**Steerer:** 260mm

**Weight:** 2.59 lbs. (1.18 kg)



## Instigator

The Instigator rigid fork replaces 100mm travel suspension forks. We designed it around the geometry of the Surly Instigator, of course, but it should work just fine for frames with similar geometries. It is constructed of thick-walled, single-butt 4130 cro-moly, so it will hold up under pressure. It's even approved for tandem use. The fork features International Standard disc mounts, removable canti pivots, 1-1/8" threadless steerer, and a black powdercoat finish. If you want to run fatties in this fork, go ahead. You can easily wedge a 2.7" tire between those straight, tapered (31.8mm to 28.6mm) blades. 447mm axle to crown.

**Rake:** 43mm

**Steerer:** 260mm

**Weight:** 3.13 lbs. (1.42 kg)



## 1x1

We now have two 1x1 forks to offer. Our 1x1 disc fork comes with International Standard mounts and removable canti pivots. Otherwise, it's the same fork as our tried-and-true original 1x1 fork...which means you can stuff 2.7" tires between the blades and have room to spare. Both forks are built with 4130 cro-moly tubing, suspension-corrected geometry, 1-1/8" threadless steerers, and black powdercoat. 413mm axle to crown.

**Rake:** 45mm

**Steerer:** 260mm

**Weight:** Disc = 2.34 lbs. (1.06 kg)

Non-disc = 2.27 lbs. (1.03 kg)



## Long Haul Trucker

Designed as the front end of our Long Haul Trucker touring frame, this fork sports a beautiful investment cast sloping crown and dropouts brazed to curved blades, dual eyelets at the dropouts for fenders and a rack, threaded bosses brazed into the fork blades for mounting a lowrider rack, and cantilever studs which work with canti or linear pull brakes. It has an 1 1/8" threadless steerer, and you have the option of choosing from 2 sizes: 700c (390mm axle to crown) or 26" wheel (376mm axle to crown). Black powdercoat finish.

**Rake:** 45mm

**Steerer:** 26" = 300mm

700c = 320mm

**Weight:** 26" = 2.11 lbs. (.96 kg)

700c = 2.25 lbs. (1.02 kg)



## Pacer

This is the same lugged and brazed fork that we provide with our Pacer road frameset. It will allow you to run 28mm tires with fenders or 32mm tires without. Many short-reach caliper brakes will work, but we can't guarantee 100% compatibility. Standard-reach calipers are recommended. This fork comes with single eyelet dropouts, 1-1/8" threadless steerer, and a black powdercoat finish. 372mm axle to crown.

**Rake:** 45mm

**Steerer:** 300mm

**Weight:** 2.17 lbs. (.98 kg)



## Steamroller

Our Steamroller fork, designed around our fixed-gear frame, is brazed with a flat crown that is drilled to accept a standard reach caliper brake. It has clearance for 700c x 38mm tires. There are no eyelets at the dropouts. Available with 1" or 1-1/8" threadless steerer. 1" measures 368mm axle to crown. 1-1/8" measures 375mm axle to crown. Black powdercoat finish.

**Rake:** 38mm

**Steerer:** 300mm

**Weight:** 1" steerer = 1.87 lbs. (.85 kg)

1-1/8" steerer = 2.15 lbs (.98 kg)

# Surly Profile: Master of Ceremonies



## Cross-Check

Our lugged and brazed Cross-Check fork has room for 700cx45mm tires and fenders. We offer it with 1" and 1-1/8" threadless steerers. It features 4130 cro-moly construction, single eyelet dropouts, cantilever brake pivots, and a black powdercoat finish. 400mm axle to crown.

**Rake:** 44mm

**Steerer:** 300mm

**Weight:** 1" = 2.11 lbs (.97 kg)

1-1/8" = 2.26 lbs (1.03 kg)



## Pugsley <sup>NEW</sup>

Our cro-moly Pugsley fork is a tapered straight blade unit, spaced at 135mm (between the dropouts) to accommodate a rear hub, and wide enough to allow a 4" tire to fit with ease. It's offset 17.5mm, to allow wheel interchangeability with the Pugsley frame. Rear international standard disc mounts and removable 120mm-spaced cantilever pivots give you brake options. The Pugsley fork comes with fender eyelets, cable housing guides, 1-1/8" threadless steerer, and black powdercoat. 447mm axle to crown.

**Rake:** 43mm

**Steerer:** 260mm

**Weight:** N/A

I'm the Master of Ceremonies in the circus that is Surly. I oversee the lobster fashion show, the weasel rodeo, the reptile scratch-n-sniff exhibit, and the occasional design and marketing of a bicycle part or two.

My qualifications? I studied engineering, studio arts, and industrial design in college. And, I managed a bike shop for several years. It's all very helpful, but I think my most valuable education comes from riding. It's the element that most qualifies me to do my share of steering the Surly short bus. I've been an avid cyclist for 13-14 years. I've traveled 70,000 miles in the saddle... give or take a few thousand, on bicycles and unicycles... many types and sizes in all types of weather. I like 'em with one gear or several gears, big wheels or small wheels, old or new, lemony-fresh or pine-scented. I ride when it's negative 25 degrees F or plus 100 degrees F, when it's sunny or snowing, day or night. I've got the clothes, bikes, and strength to do it, so why not?



I have a 32-mile round-trip mostly-suburban commute to and from the office, and I pedal in each day. My time in the saddle is my time for meditation. The commute typically affords me 10-15 hours a week, away from a telephone, to think about my family, my friends, all aspects of my job, and the state of the world we live in. I think my commute is one of the most important parts of my workday. I get more done on the bike, in a couple of hours, than I do sitting in the office all day. Sure, I know what you're thinking. "Why don't you just ride around all day? You'll get so much done." I tried that, and I got too tired. I kept falling asleep in strange places and waking up without my wallet or hair pick.

I still love to ride 250+ days out of the year. The ever-changing variables, of the ride, keep things interesting. The scenery changes...I have dozens of different routes to ride. The vehicle changes...I have a garage full of bikes to choose from. The climate changes whether I like it or not...It's Minneapolis, so it can be sunny and 75F one day and snowing the next. Even the smell and color of the dumpster juice behind Lund's supermarket, on Penn and 62, changes every couple of days. Mmmm...expired gilets. Regardless of what, where, when, and how I ride, it's always educational. It always gets my blood moving in a good way. And, it's always better than being stuck in freeway traffic.

What's my motivation to show up to work on a semi-regular basis? I originally pursued the bicycle industry for all of the fame and fortune it has to offer. You know...the rock star lifestyle: booze, chicks, and parties 24/7. But, then, I realized that there was more to it. There are fun and interesting niches to fill. There are nonexistent products that need to be designed and manufactured. There are existing products, on the market, that can be improved upon. And, occasionally, it's appropriate to bring back and improve a component that has been discontinued by another manufacturer. I'm motivated by the creative process and the challenge of turning ideas into products that I want to use.

Well, enough about me. How about you? Is that a new brooch you're wearing? It's very nice. That orange-brown hue is really you. I like the way it accentuates your eyeball. No, I mean it. You've got style. Don't let anybody tell you differently.

# Stainless Steel Chainrings

Why the heck would we produce chainrings when there are already so many chainrings on the market? Because stainless chainrings are tougher than aluminum chainrings. For single-speed and tandem timing chain applications, where the wear isn't shared between 2 or 3 chainrings, our rings will outlast and outperform aluminum. You can certainly use them for multi-chainring applications, but they aren't ramped or pinned, so shifting up to our ring (used as a middle or outer ring) might be a bit slower than what you are used to. Our rings are compatible with 6-speed to 9-speed chains. 10-speed chains may fit tightly on our rings until they've been used for awhile.

**Sizes:** 94mm BCD x 30t, 32t, 34t, & 36t.  
104mm BCD x 32t, 34t, & 36t.  
110mm BCD x 34t & 36t.



NEW

# Cassette Cogs



SCM 415 cromoly steel. This is a hardened cromoly; looks good, lasts a long time. Match one of our stainless steel chainrings to one of our chrome-plated cogs, and you've got a drivetrain built to last. Designed to fit Shimano freehub bodies. The Shimano freehub spline is the most common design out there, used on Shimano brand and many non-Shimano hubs. You're likely using this cog to convert your current wheel to single speed. The tooth shape and height are ideal for single speed drivetrains. The footprint of the cogs (where they fit onto

the FH) is wider than most SS cogs so they don't dig into the FH and get sloppy. This is especially important if your FH body is aluminum or titanium.

The wide footprint serves 2 purposes: anti-dig as mentioned, and they're 9 speed drivetrain spaced, so you can stack them up for several gears (orient them the same direction on the FH body for this purpose). Because they're designed as single-speed cogs first, they'll shift a bit slower than a regular cluster, but we've had good results running several cogs. Like a single but want a bailout or catch up gear? Here's your answer. Compatible with all 6, 7, 8 and 9-speed chains. Available in all sizes from 13T-22T.

# Track Cogs

New &amp; Improved!

Surly fixed gear cogs are machined from SCM 415 cromoly and hardened to resist wear. We've redesigned them recently too, so the footprint is slightly wider than before. They should work well regardless of how much thread your fixie hub has. Our cogs are ISO threaded (1.375" x 24tpi), so they'll fit most English, Italian and Japanese hubs, including our own New fixie hubs and Fixxer hub converter. Surly cogs are available in 3/32" and 1/8" widths, in 13-22t; no gap in the size range.



# Track Lockrings

New &amp; Improved!

CNC machined of premium stainless steel...no flaking chrome or rusting. We've changed the design to increase thread contact. Fits English lockring threads (1.29" x 24tpi LH) and will work on almost all track hubs available today except Campagnolo (1.32" x 24t LH) and French (33 x 1mm LH).



New &amp; Improved!

# 1x1 Singleator™

Midwest single-speed legend Pete Geigle developed the 1x1 Singleator, so you single-speed virgins could taste the pure mountain biking experience without spending too much cash.

Installing horizontal dropouts on your frame can be difficult and/or expensive, particularly if your steel is of the aluminum variety. The Singleator mounts right up to your derailleur hanger and provides a simple, effective, and adjustable means of tensioning the excess chain slack found in vertical dropout single-speed drive trains.

The Singleator features a triple sealed spring, large cog capacity, chain guides, fully adjustable chain line, floating pulley, and a stainless steel pivot bushing. We've made some improvements over our original Singleator, too: The main body is forged, so it's strong. We've gone with an 11 tooth pulley for smooth, quiet operation. And, it now works with both 1/8" (BMX) and 3/32" (geared bikes) chains. Beware imposters; the Singleator is the granddaddy and outperforms all others.

Colors: Black or Silver



## The 1x1 Speed Gear Chart

1x1	24	26	28	29	30	31	32	34	36
16	1.50	1.63	1.75	1.81	1.88	1.94	2.00	2.13	2.25
17	1.41	1.53	1.65	1.71	1.76	1.82	1.88	2.00	2.12
18	1.34	1.45	1.56	1.61	1.66	1.72	1.78	1.89	2.00
20	1.20	1.30	1.40	1.45	1.50	1.55	1.60	1.70	1.80
22	1.09	1.18	1.27	1.32	1.36	1.41	1.45	1.55	1.64

# 1x1 Torsion Bar™

Made for us by NITTO®, these wide, flat, 4130 cro-moly bruisers will give you a distinct advantage in any derby situation. With a 15° bend, and 24.5" width, they're also mighty comfortable. Get ready to flat track!

Color: Silver

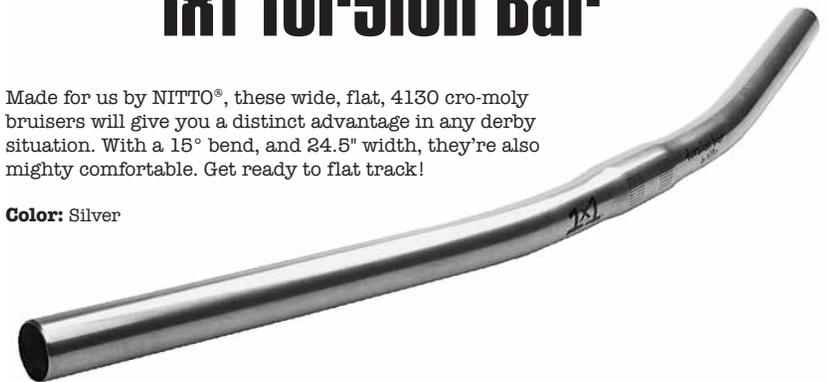

# New™ Hubs

Your basic hubs. Sorta like Chuck Taylor high tops for your bike. All are forged aluminum, high flange, and spin on high load, well-sealed, adjustable cartridge bearings over solid or QR axles (9x1mm front, 10x1mm rear). It's easy to find replacements should the need arise. Fronts are spaced 100mm to fit most forks. Fixed-gear rears are spaced 120mm and are ISO threaded on both sides for fixed gear cogs (1.37"x24tpi) and lockrings (1.29"x24tpi LH). 135mm-spaced rears are available as dual freewheel, with threading on both sides for single speed freewheels (1.37"x24tpi), and as fixed/free, with free-wheel threading on one side and fixed-gear/lockring threading on the other. We now offer this fixed/free hub in a 120mm-spaced version, as well. Black fronts and MTN rears now are available with hollow QR axles. Drilled for 32 or 36 spokes, laser etched with the Surly logo.

**Color:** Black or Silver



# New™ Disc Hubs

Single speed disc hubs for people like you. Much like our regular New hubs, but with a 6 bolt rotor mount. Fronts spaced 100mm, rears 135mm. Rear is single speed freewheel threaded 1.37"x24tpi. They use the same internals as the other hubs we offer. Black available with hollow QR axle.

**Color:** Black or Silver



# Fixxer™ Hub Converter

Even if it ain't broke, you can still "fix" it with our Surly Fixxer hub converter. The Fixxer allows you to cheaply and easily convert any Shimano® cassette hub (except Silent Clutch, post-2003 Dura Ace or pre-1997 Dura Ace) into a true fixed-gear. By simply removing the cassette body and replacing it with our adapter, you can use a fixed track cog and lockring for safe coast-free riding. A popular conversion for track racers, springtime trainers, fixed-gear commuters and messengers, the Fixxer includes all parts necessary for installation, including axle, bearing, cones, spacers, and axle nuts. Most converted hubs can be spaced 120, 126, 130 or 135mm, and can even be used with a freewheel if a free-wheeling single-speed conversion is desired.

**Color:** Silver



NEW

27

# Large Marge™ Rim



John Evingson (Hydracare owner, custom framebuilder, and adventure rider/racer) came into the office, one day, with one of his steel adventure bikes that was sporting 80mm-wide rims and 3.0 tires inflated to 12 psi. After a few laps around the building and a few intentional curb bashings, it was easy to understand why a machine like John's should exist. The giant footprint and low pressure, provided by those rims and tires, gave the bike incredible traction, comfort, and stability over loose and choppy surfaces. Awesome. It's apparent that snow bikers, sand crawlers, off-road unicyclists, and downhillers, who want to run some really big rubber, can benefit from a wide rim/tire combo. But, the rims (Remolino) and tires (single-ply Specialized Big Hit 3.0), that John was using, are no longer manufactured. After talking with John and Pat Irwin (Surly-sponsored adventure rider/racer and owner of Pat's Bikes, in Anchorage) at length, we decided to fill the wide rim void. 3.0 DH tires are readily available, albeit heavy, so the need for a rim was decidedly more urgent than the need for a tire. Surly adventure tires will come later...hopefully, by late summer/early fall 2005.

So, we introduce to you...Large Marge. Our black anodized, eyeleted, double-walled 24" and 26" hoops are 65mm wide. They feature machined sidewalls for those of you who may want to use rim brakes...Magura hydraulic rim brakes, traditional cantilevers, v-brakes with 2.2-2.4 tires (larger tires may interfere with the cross-over wire). The cross-sectional profile gives our rim incredible strength, while shedding

snow and sand to keep the rotational mass as low as possible.

We offer Large Marge in a number of configurations: 32-hole and 36-hole downhill rims are available in 24" and 26" sizes, and a 32-hole cruiser/cross-country version is available in the 26" size. What's the difference between the cross-country and DH rims? The cross-country rim is machined, at its outer wall, to shave some grams. What's the weight? The 26" DH rim...1150grams, the 26" XC rim...1050grams, and the 24" DH rims...1050grams. All are drilled for Presta (French) valves, but any bike shop can drill them out for use with Schrader (American) valves.

You're going to need a DH-style frame and fork, or a non-standard XC frame and fork to use Large Marge rims. Most stock XC frames and forks simply don't have the clearance for wide rims and rubber. There are custom builders, like John Evingson, who will be happy to build a frame and fork for you. Or, you could chop the cantilever bosses from a 1x1 frame and fork or from an Instigator frame and fork. Depending on the make and model of tire, and the position of the wheel in the rear dropouts, 2.7"-3.0" tires will fit in the 1x1 frame. The Instigator can handle 2.6"-2.7" tires.

We're going to offer a special Pugsley Large Marge that will be drilled differently than the stock rims to give more dish to the disc side of an offset wheel using a disc hub. The Pug-specific rims should be available around the same time Pugsleys arrive in our warehouse. Details will be available on our website as soon as we have the specifications finalized.

# Nice Rack™

We thought our Long Haul Trucker touring frame deserved some durable, affordable, expedition-worthy racks to compliment it. So we designed the front and rear Nice Racks.

We chose to make them out of cro-moly (surprised?) due to its durability and ease of repair compared to aluminum. Repairability should be a consideration for any product that will be used in every extreme. In the rare instance that the rack breaks, you should be able to find, even in the most remote regions of planet Earth, somebody to TIG, MIG, stick weld, or braze or solder a Nice Rack back together. An aluminum rack won't afford you the same luxury.

Our height-adjustable front rack is a lowrider/highrider design. Panniers mounted in the lowrider position provide a more stable ride, but can be a burden when riding rocky or rutted roads and trails. The upper rails on the rack provide an alternate pannier mounting position for these types of conditions. The rack platform above the wheel increases your cargo capacity. It's a great place to carry a light sleeping bag or small tent if you don't have room elsewhere. Our front Nice Rack mounts directly to forks equipped with a mid-blade eyelet, located approximately 165mm from the dropout eyelet. This is a standard eyelet location found on many touring-specific forks, including our Long Haul Trucker fork. We do, however, provide hardware to securely mount a Nice Rack on forks that do not have a mid-blade eyelet. For example, you can mount a Nice Rack on an Instigator fork, a 1x1 fork, or a Karate Monkey frame using the supplied mid-blade adapters...which means you can mount it on almost any rigid fork.

The rear rack is also height-adjustable, so you can get your center of gravity as low as possible to provide a stable ride. The hardware included with our rear rack allows it to work with all sizes of our Long Haul Trucker touring frames (42cm - 62cm), so it should easily mount to your frame, as well. Its wide platform has plenty of room for rack trunks, sleeping bags, tents, boxes of lima beans, or small cages full of hamsters.

Nice Racks are powdercoated black or silver for corrosion resistance and good looks. The stainless steel hardware we provide will enable you to fit them to most rigid 26" and 700c frames, and to forks equipped with drum, caliper, or cantilever brakes. Disc brakes and suspension are generally not compatible with our racks.



Front



Rear



## Instigator Dropouts

Our heavy-duty Instigator dropouts are investment cast cro-moly and include international standard disc mounts. They can be TIG'd or brazed.

## Frame Dropouts

Our investment cast cro-moly horizontal dropouts come in two versions: with or without derailleur tab. These are the same dropouts that we use on our 1x1, Steamroller, and Karate Monkey frames. They can be TIG-welded or fillet brazed.



## Disc Housing Guides

Investment cast cro-moly. TIG-weld or fillet braze them on. Plenty o' room for zip ties.

## Constrictor™ Seatpost Clamp



The Constrictor was designed specifically to end slipping seat posts. The extra-thick clamp utilizes an 8mm stainless bolt and accommodates a rear cantilever brake hanger, if you decide to go that route. The Constrictor is machined out of aluminum billet and black anodized. It's available in 30.0mm and 31.8mm sizes.

# Surly Profile: Stooge

## Tuggnut™ Chain Tensioner

Ever stomp on the pedals just to have your rear wheel slide forward in the dropouts and throw your chain? We have....using all kinds of hubs in all kinds of frames. There are lots of BMX-style tensioners out there, but few of them fit in our dropouts without some serious grinding. So, we decided to design a chain tensioner that will keep that rear wheel static in our dropouts...and most other kinds of rear-facing horizontal dropouts. Plus, ours will open up a bottle o' brew. The body of the Tuggnut is investment cast in stainless steel for durability. It features a winged bolt for tool-free adjustments, and 2 axle holes for a wide range of fore/aft wheel positions. The Tuggnut comes with an aluminum adapter that reduces the axle hole from 10mm to 6mm, so you can use it with quick-release axles, in addition to nutted axles. We sell it as a single, because you really only need one...on the drive side. But, if you absolutely need one on the non-drive side of your rig, to achieve balance in your life, you are in luck...the bottle opener works either way.



## Surly Hip Flask

Stainless steel. 6oz. (177ml)

Holds your precious liquids, and is derby approved. You wouldn't want to fall on a glass bottle would ya?



## Jethro Tule™

Surly's Jethro Tule pocket tool is crafted from stainless-steel, then polished to a high luster. It combines an offset box wrench on one end with a leverage-enhanced bottle opener on the other.

The double-sided 15mm box wrench works with most bolt-off hubs on the market. And, it fits quite nicely inside recessed dropouts, including those found on our Surly 1x1 frame. Quit carting around the Vice-grips™; our smooth, spoon-shaped handle provides ergonomic pleasure for your palm under the most rigorous wheel-removing operations, at a fraction of the weight and bulk. And, it snaps open the fizzy reliably before, during, and after the ride. The Jethro Tule hangs nicely on a key chain and is light enough to carry comfortably anywhere, but being "Thick as a Brick", it is built to last and to resist bouncing out of your pocket during a rough singletrack ride, or crosstown jaunt.



**Name:** Nick Sande

**Born:** 1971 in Minneapolis

**Occupation:** random mix of design, quality control and customer service

**Other talents:** making stuff into brewing equipment, making beer out the stuff I made into brewing equipment, drinking the beer I made out of the stuff I made into brewing equipment while making more stuff into brewing equipment.

**Future ambitions:** ride a unicycle, continue to scare people on Halloween, cycle tour far enough away from civilization that I get scared and can't wait to get home, personally thank Jimmy Carter, ride the entire 35 km of the frozen Minnehaha creek, make SPD compatible moonboots that look like something Gene Simmons would wear, retire with my lady in a warm place.

**Turn ons:** bacon, Black Sabbath, american pale ales, fresh warm donuts, riding alongside the Minnesota river home from work, and pigtail braids.

**Turn offs:** new country music, ignorance, U.S. foreign policy, laziness, greed, fake attitudes, shaving and long pants.

**Functional bikes:** 7, plus 1 skibike. Pacer singlespeed summer commuter, Karate Monkey singlespeed 1st choice off-road ride, lugged steel self-built city cruiser 8-speed for my bar bike and lolly gagging around town, Long Haul Trucker 7-speed winter commuter, 1x1 singlespeed derby bike and ice riding bike, hand-built steel Mark Zeh mountain bike which is currently a singlespeed that gets ridden about once a year, Cross-Check commuter singlespeed. My skibike is a Salsa Caballero full-suspension with suspension seat-post and chopped off Rossignol kid's skis from the garbage.

**If I had the time and money I'd:** kidnap and brainwash my least favorite politicians into thinking they live on the streets in a country they bombed or embargoed, and must now play music for pocket change. After that, I'd make sure all the school teachers, people working for minimum wage and tree huggers rode their bikes past them and told them the song they were playing sucked.





# Tee Shirts



**NEW**

## Karate Monkey Baseball Tee

- Gray and black
- Sizes: M-XXL



## Karate Monkey Tee

- Black
- Sizes: M-XXL



## Long Sleeve Logo Tee

- Black
- Sizes: M-XXL



## Girly Tee

- Black
- Sizes: S-XL



## Logo Tee

- Black
- Sizes: S-XXL

# Wool Jerseys

## Men's

- 100% Merino wool
- Available in short or long-sleeve
- 11" zipper
- Rear pockets
- Embroidered logos
- Black
- Sizes: S-XL

**Why Wool?  
see page 34**



## Women's

- 100% Merino wool
- Available in short or long-sleeve
- 11" zipper
- Rear pockets
- Embroidered logos
- Black
- Sizes: S-XL



## Socks

- 75% Merino wool, 25% nylon and spandex
- Black
- Sizes: S/M, L/XL, and XXL Sasquatch
- 2 cuff heights: 3" Racer Geek, and 5" Nerdlinger



## Baseball Cap

- Embroidered logo
- Flex-fit
- Black
- Sizes: S/M or L/XL



# Why Wool?

Our wool clothes are made from Merino, a very fine, soft, itch-free wool which feels much like cashmere next to the skin. Like all wool, it has wicking characteristics superior to any synthetic. This means it keeps moisture off your skin and insulates to help you maintain a comfortable operating temperature even when the material itself is pretty well soaked (cotton, for example, simply gets wet and makes you feel clammy, so your body uses valuable energy trying to keep you warm). Wool is warm in cool and cold weather (it's the perfect base layer), and yet remains surprisingly comfy when the weather is warm. And because wool fibers can actually absorb moisture, rather than simply pulling it away from your skin, the bacteria that cause synthetics to stink don't build up. In fact, you don't want to wash our wool jerseys and socks every time you wear them. But when it is time to wash them, you can toss them in the machine on the gentle cycle (cold water!) and then air dry them. Back in the day, cyclists all wore wool, and this is better than anything they had back then. Find out why.

## Banner

- 36x18" or 3x6'
- Black nylon
- 4 Grommets
- Screen printed



## Patches

- Sizes:  
6.5" wide  
10" wide



## Stickers

- Sizes:  
1.75 x 6.4"  
12 x 2.73"  
24 x 5.46"



## Frame Decal Sets

- Complete decal sets are available for each frame we sell
- Decals are dry transfer style
- Each decal set includes a headbadge



# Surly Profile: Ghost in the Machine

The year was 1969. A nation was divided over an unpopular war, Easy Rider was in the theaters, Elvis Presley's In The Ghetto cracked the top ten, and I was unleashed on the world. Within 7 years I was riding a bicycle (thanks in great part to my hot older neighbor Shannon, who helped me learn to stay upright on her Free Spirit). The next year my parents bought the bike shop in town and nothing's been the same since. Despite this, my first -and perhaps hardest ridden- bike was not a nice one. It was a used Rollfast 20" that my grandmother found at a garage sale. I think my dad assumed it was cheaper to keep fixing it than to buy something new that I would definitely outgrow and probably destroy. I crushed the competition in flat-out street races, used it as commuter, dirt trail rocker, and, using a homemade ramp, jumped increasingly longer and higher, managing somehow not to break anything on my body. After that, it all starts to blend together. I now have a garage full of bikes in various states of operation, plus a bunch in the basement and some in the front entryway. I have a Bendix 2 speed kick-back hub on one of the cabinets upstairs. It looks as much like sculpture as any of the pieces of 'deliberate' art which surround it. I have a pile of tires in my basement, a bunch of old 3 speed wheels waiting for frames, and several junk bikes in my yard as lawn sculpture. Of course, I also have a bunch of Surlys and, though I know I'm biased, they continue to be some of my all-time favorite rides. Give one a try, I think you'll agree.



### Contact Us

**SURLY™**  
6400 W. 105th St.  
Bloomington, MN 55438

Phone: 877.743.3191  
Web: [www.surlybikes.com](http://www.surlybikes.com)  
E-mail: [derby@surlybikes.com](mailto:derby@surlybikes.com)

### Surly® Engineer

Josh Yablon  
1.800.346.0004 ext. 1357

### Surly® International

Jolly Green Peter Redin  
952.941.9391 ext. 1244

### Surly® Media Slut

Colin Floyd  
952.941.9391 ext. 1309



6400 W. 105th St.  
Bloomington, MN 55438